

THE DIAPASON

AN INTERNATIONAL MONTHLY DEVOTED TO THE ORGAN, THE HARPSICHORD AND CHURCH MUSIC

Seventy-Second Year, No. 4, Whole No. 857

A Scranton Gillette Publication

ISSN 0012-2378

APRIL, 1981

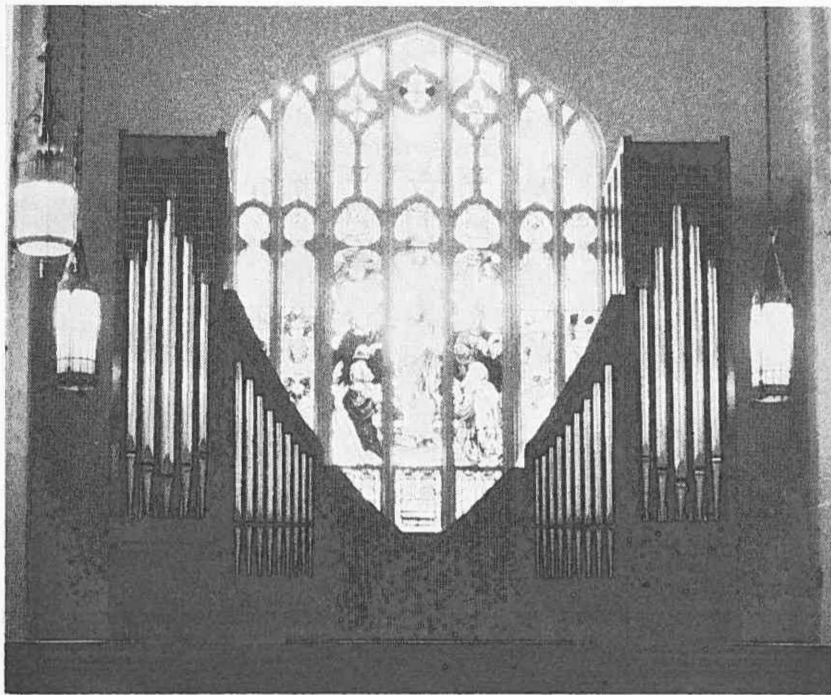

The Steiner organ in Trinity Lutheran Church, Greenville, South Carolina (specification on page 18).

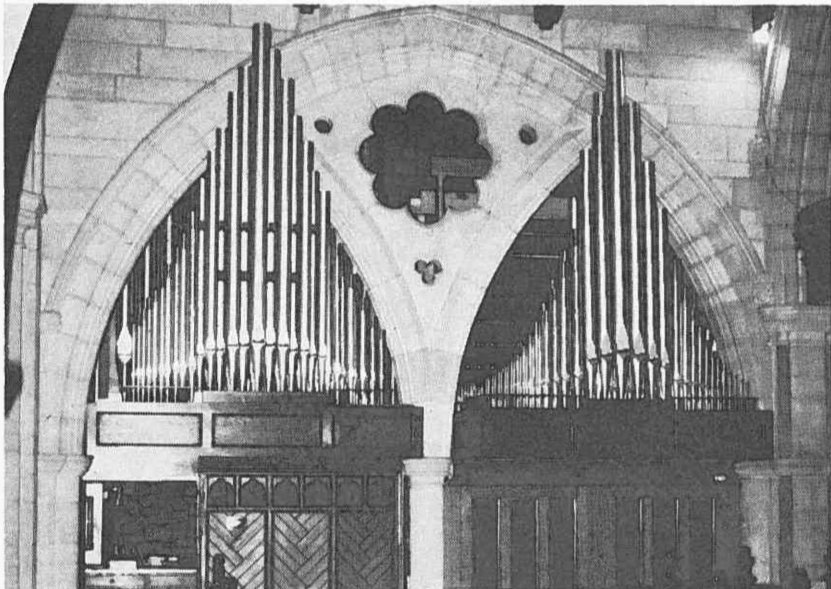

The Austin organ at St. Peter's Episcopal Church in Phoenixville, Pennsylvania (specification on page 18).

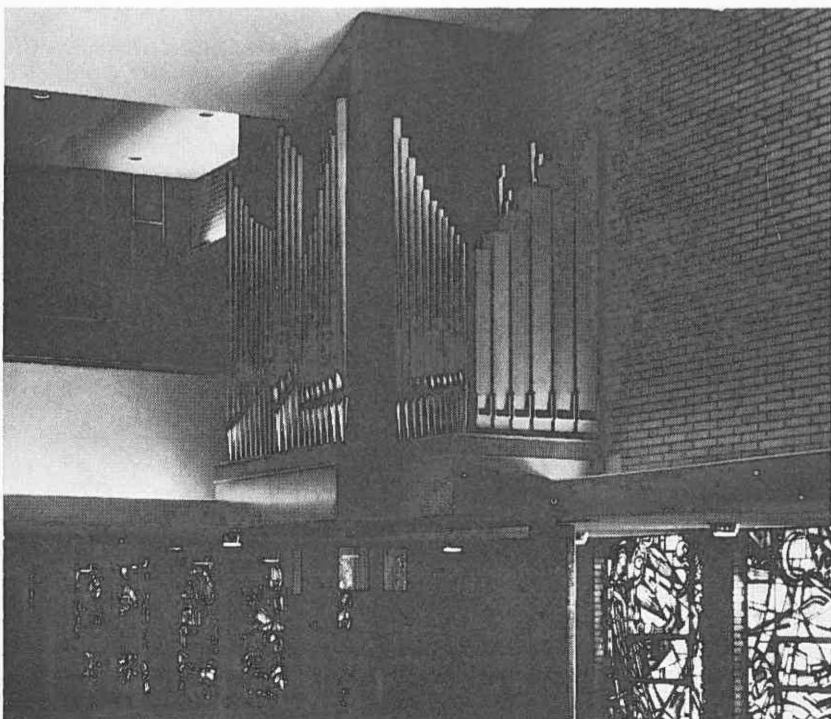

The Wicks organ in Trinity Evangelical Lutheran Church, Waukesha, Wisconsin (specification on page 18).

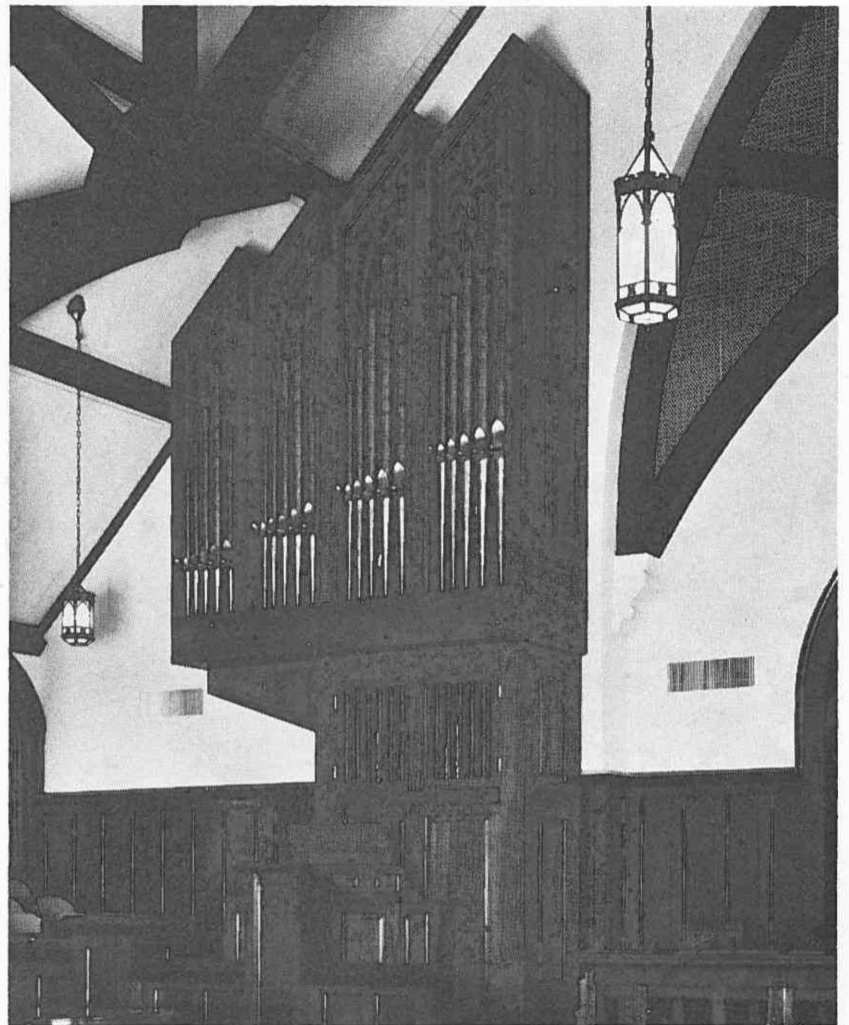

The Schudi organ at Central Christian Church in Texarkana, Texas (specification on page 18).

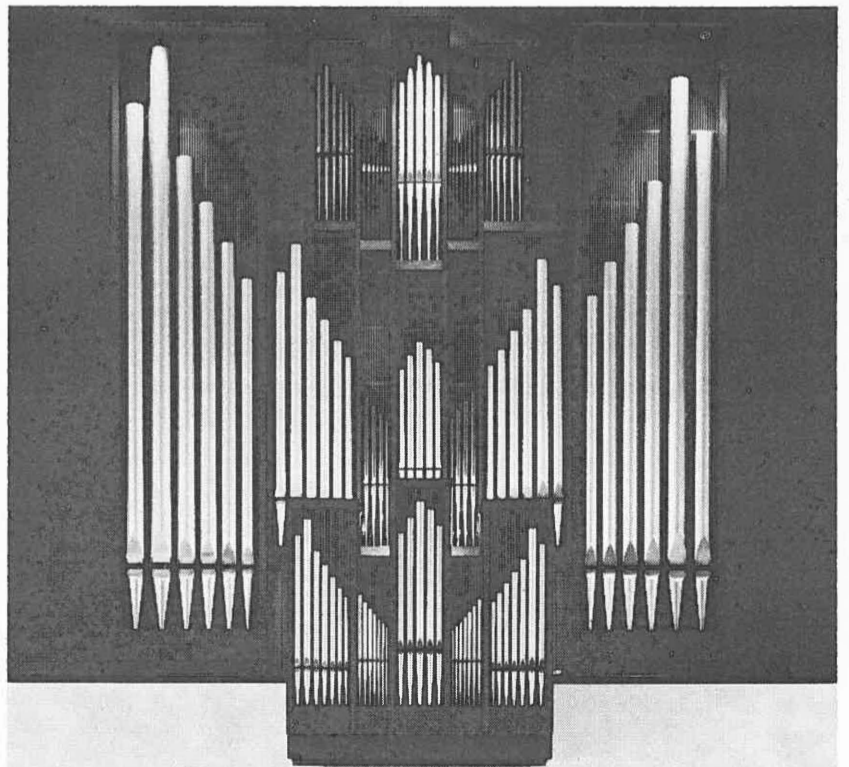

The Gress-Miles organ in the First Church of Christ, Congregational, of Suffield, Connecticut (specification on page 18).

In This Issue

There is a wide variety of material in this issue, which is the largest one published by *The Diapason* in eleven years. Quality, one hopes, counts for more than quantity, but when there is more good material awaiting publication than can be printed, it is heartening that a large volume of advertising permits a large amount of news and articles to appear.

In addition to reviews of two organ conferences, four feature articles are devoted to four aspects of the organ. Concerning the biography of its players, a reminiscence of Ernest White by one of his students when he was at the Church of St. Mary the Virgin in New York City provides some recognition of the work and thought of this remarkable organist who died last fall. Relatively little material appeared in this magazine regarding him during his life; perhaps he didn't like the name, since he apparently did not like the stop, so there is all the more reason for an appreciation now.

An article on the revival of tracker organbuilding in northwest Ohio reveals some interesting trends in an area which has not been thought of as the avant-garde of new instruments, even though several of the builders are well-known. Some of the organs mentioned will be heard in the forthcoming Toledo AGO Regional Convention.

An essay on organ sonority yields some insights for selecting stops appropriate to certain types of organ music. The author does not deal with specific "rules," but rather mentions ways in which instrumental and vocal music can suggest general types of registration for analogous organ works.

Finally, an article on graphing the pitches of mixture patterns rounds out the issue. The technical nature of this subject will not make it fascinating reading for all, but a study of the illustrations can show the organist some general types of mixture composition, and the material should be of value to all serious organbuilders.

The Graduate

What should the prospective graduate in organ, church music, and/or teaching expect in seeking a job today? Very little, quite frankly — the economy is bad and the job market is worse. You can't even plan to fall back on a temporary job teaching public school or working on an automobile assembly line anymore, because those fields have more workers than work. Shoe sales are uncertain at best. World economic conditions have their ups and downs, of course, but I suspect that the outlook for positions in music has always been discouraging. However, there are opportunities for those who want to work hard and who are willing to keep trying, even though the situations are usually far from ideal.

A good teacher and school can be wonderful for the knowledge they impart, and the student is well-advised to take full advantage of them while he or she can. Nevertheless, the actual conditions of most positions are not what one would guess from spending time in classrooms, libraries, and practice rooms. Here are some points for any job-seeker in our area to ponder (please pardon the editor-on-a-soapbox):

1. *Don't expect too much of a job.* Most positions, whether organist of a grand cathedral, teacher at a great university, or vice-president of a national firm, are not as golden as they may seem. One must put up with stupid bosses, insensitive colleagues, and difficult choir members. One must be willing to do work which ought to be beneath one's dignity and educational level; otherwise, it probably won't get done. The effectiveness of the music which covers the minister's movements may be judged more important than a professional-calibre recital. The pay is always lower than it should be and the fringe benefits may be imaginary. You will undoubtedly be imposed upon. The archbishop of Salzburg may have appreciated Mozart only in his absence.

2. *Make the most of the situation,* even if it is a bad one. Turn disadvantage to your own advantage. If the organ is a big tub, don't bewail its lack of a Bach Division; instead, find the music that works best on it and play it as well as possible, even if that means orchestral transcriptions and accompaniments. If it is shrill and chuffy, spare your listeners an abundance of Reger, and try something with a lighter texture. If your choir has fifteen sopranos, ten altos, three basses, and only a visiting tenor, don't rebuke them for singing the Brahms *Requiem* inadequately; rather, seek out interesting two- and three-part music while you recruit more men. Schütz probably wouldn't have enriched the choral literature with so many wonderful monodic sacred concerti if he had had a well-balanced choir, but many of his best singers became victims of the Thirty-Year War, so he had to "make-do" with what he could. Start a concert series rather than bemoan the lack of one; if there are no funds, begin simply, use your performance-hungry friends, and gradually evolve the program you desire. Writing in a recent issue of *The American Organist*, concert manager Karen McFarlane put it very aptly: *imagination* brings better results than magic.

3. *Have patience.* Slowly educate your minister and music committee if you find their priorities wrong. Start a solid plan to repair the organ, if that's needed, working methodically rather than recklessly. Reason with your chairman regarding curriculum changes you may deem necessary. Initiate a well-planned choral program. But don't expect any of these things to happen overnight. For any example you care to cite — a fine organ, a noted concert series, an outstanding choir, a distinguished liturgical program — someone invested time and effort to establish it. Magic strikes less often than lightning. Buxtehude didn't gain fame for *Abendmusiken* in one evening. Study the history of Rome.

4. *Go out of your way to get along.* The bottom line of any job is getting along with others — working with people. They come in all sizes, shapes, and personalities, and you shouldn't be surprised if you encounter some of each. They can be both good and bad, and they can make or break you, so gird yourself with common sense.

5. *Never say die.* Success comes most often to those who don't give up, but the musical world has its own aspects of cut-throatedness and competition, and often only the bravest and fittest survive. Leipzig comes after Arnstadt, but even there you may have to teach disagreeable students and endure the town council.

—A.L.

THE DIAPASON

Established in 1909

An International Monthly Devoted to the Organ, the Harpsichord and Church Music
Official Journal of the American Institute of Organbuilders

APRIL, 1981

FEATURES

My Association with Ernest White by H. F. MacEwen	12-13
Renaissance in Organbuilding in Northwest Ohio by James J. Hammann	14
Some Thoughts on the Sound of the Organ by John David Peterson	16-17
The Graphic Representation of Repeating Mixtures by Ch.-W. Lindow	20-22

REVIEWS

Music for Voices and Organ by James McGray	4
Ann Arbor Conference Concerts by Anne Parks	26-27
Sacred Music Convocation at Davidson College by Arthur Lawrence	28

EDITORIALS

LETTERS TO THE EDITOR	3, 10
-----------------------	-------

NEWS

Announcements	2, 25
Nunc Dimittis	3
Harpsichord	6, 8
Here & There	8, 19, 23
Article Noted	10
Honors	13
Summer Events	15
AGO Regional Conventions	19
Appointments	23-24

NEW ORGANS

CALENDAR	29-32
----------	-------

CLASSIFIED ADVERTISEMENTS

	33-35
--	-------

Editor & Publisher ARTHUR LAWRENCE
Business Manager DAVID MCCAIN
Assistant Editor WESLEY VOS
Contributing Editors LARRY PALMER
Harpsichord
JAMES McCRAY
Choral Music

BRUCE GUSTAFSON
Musicology
MARGO HALSTED
Carillon

Foreign Correspondents DALE CARR
Groningen

LAURENCE JENKINS
London

SUSAN FERRE
France

Prices:
1 yr.—\$10.00
2 yrs.—\$18.00
3 yrs.—\$26.00
Single Copy—\$2.00

Back issues over one year old are available only from The Organ Historical Society, Inc., P.O. Box 209, Wilmington, OH 45177, which can supply information on availabilities and prices.

THE DIAPASON (ISSN 0012-2378)
is published monthly for \$10 per year
by Scranton Gillette Communications,
Inc., 380 Northwest Highway,
Des Plaines, IL 60016.
Phone (312) 298-6622.

Second class postage paid at
Des Plaines, IL and additional
mailing offices.

POSTMASTER: Send address changes
to THE DIAPASON, 380 Northwest
Highway, Des Plaines, IL 60016.

Routine items for publication must be received not later than the 1st of the month to assure insertion in the issue for the next month. For advertising copy, the closing date is the 5th. Materials for review should reach the office by the 1st of the previous month. Prospective contributors of articles should request a style sheet. Unsolicited reviews cannot be accepted.

This journal is indexed in The Music Index, annotated in Music Article Guide, and abstracted in RILM Abstracts

All subscribers are urged to send changes of address promptly to the office of The Diapason. Changes must reach us before the 10th of the 2nd month preceding the date of the first issue to be mailed to the new address. The Diapason cannot provide duplicate copies missed because of a subscriber's failure to notify.

No portion of the contents of this issue may be reproduced in any form without the specific written permission of the Editor, except that libraries are authorized to make photocopies of the material contained herein for the purpose of course reserve reading at the rate of one copy for every fifteen students. Such copies may be reused for other courses or for the same course offered subsequently.

Announcements



Gunther Schuller, shown above at the Fisk organ in House of Hope Presbyterian Church, has been commissioned by the church to compose an organ symphony, which will be premiered at the St. Paul, MN church on May 3 at 4 p.m. Clyde Holloway will perform the new work. Mr. Schuller's only previous organ work is "Triptych," which was commissioned by the AGO for performance in 1976 at the national convention in Boston.

An Organ Dedication Weekend has been announced by Phillips Academy for May 22-24, to celebrate the installation of two new organs built for the academy by the Andover Organ Co. The featured recitalist on Friday evening will be Karel Paukert; seminars the following day will be given by James Darling, Daniel Pinkham, and Elizabeth Sollenberger. Further information is available by writing Organ Dedication Weekend, Phillips Academy, Andover, MA 01810.

A two-day symposium on Bach's *Art of Fugue* will take place at the First English Lutheran Church of Appleton, WI, May 15-16, sponsored by the church in conjunction with the Northeastern Wisconsin AGO chapter. The first evening will be devoted to a performance of the complete work by Thomas F. Froehlich; papers on the composition will be given the following day by Michael R. Fisher and Dorothy Lane. For further information, write International Organ Festival, 326 East North St., Appleton, WI 54911.

The Hymn Society of America has appointed the Hope Publishing Co. of Carol Stream, IL, to be its agent for all copyrighted works. The action will permit copyrighted texts and tunes of the society to be published and disseminated.

Nunc Dimittis



Karl Richter, German organist, harpsichordist, and conductor, died Feb. 16 in a Munich hotel of an apparent heart attack. He was 54.

Born Oct. 15, 1926, in Plauen, Saxony (now in East Germany), he was educated at the Dresden Kreuzschule and then at the Leipzig Conservatory, where he studied with Rudolf Mauersberger, Günther Ramin, and Karl Straube. He became choirmaster of the Christuskirche in Leipzig in 1946 and a year later was appointed organist of the Thomaskirche there. In 1951 he moved to Munich, where he taught at the Hochschule für Musik, advancing to a professorship in 1956, and was cantor of the Markuskirche. He founded the Munich Bach Choir and Orchestra, a group which became well-known during the following thirty years through tours and recordings. The first U.S. tour took place in 1965, with one to Moscow and Leningrad in 1968, when performances of the "St. John Passion" and the "Mass in B Minor" were featured. Mr. Richter's final New York concert took place last June 13 at Avery Fisher Hall, when he conducted Bach and Handel for the Basically Bach Festival.

Although Mr. Richter was a leader of the Bach revival of the 1950s and '60s, his interpretations were variously regarded as "de-Romanticized, cool, and abstract," or "rigorous and emotional," depending on the critic's viewpoint. He did not endorse the latest performance-practice trends, and his own playing was characterized by an avoidance of a would-be "historical" style, stressing flexible registration and large-scale dynamic contrasts. He attributed the zeal for authenticity to "a certain snobbishness," commenting that "many of the 'discoveries' just lead to confusion," but he maintained that good Bach performances would always keep that composer's music vital and timely.



Howard Hanson, American composer and educator, died in a Rochester, NY, hospital on Feb. 26. He was 84. He had been director of the Eastman School of Music from 1924 until his retirement 40 years later.

Born Oct. 28, 1896, in Wahoo, NE, of Swedish descent, he graduated from Luther College in Wahoo, then attended the University of Nebraska. In 1914, he received a diploma from the Institute of Musical Art (predecessor of the Juilliard School), studying composition with Percy Goetschius and piano with Frank Damrosch. He went on to Northwestern University in Evanston, IL, where he worked with Peter C. Lutkin and Arne Oldberg. He subsequently taught theory at the College of the Pacific in San Jose, CA, and served as that institution's dean from 1919-1921. He won the Prix de Rome in 1921 and spent three years at the American Academy in Rome before being asked to head the Eastman School three years after its founding. He won the Pulitzer Prize in 1944 with his 'Requiem' Symphony (No. 4).

A prolific composer of instrumental and orchestral works, Howard Hanson championed the cause of American music throughout his life and was responsible for the performance of many new works, both from his own pen and from the hands of others. The Metropolitan Opera staged his opera "Merry Mount" in 1933, but his First Symphony ('Nordic') had brought him to attention as early as 1923. His Concerto for Organ, Strings, Harp, and Orchestra was written in 1921, while another Concerto for Organ and Orchestra dates from 1926. Among his choral works, the "Cherubic Hymn" of 1949 received many performances.

He had remained active as a lecturer, writer, and composer while in official retirement, and maintained close ties with the Eastman School, to which he returned to conduct in 1979. A chapel, recital hall, scholarship, and composition award bear and honor his name at the Rochester institution.

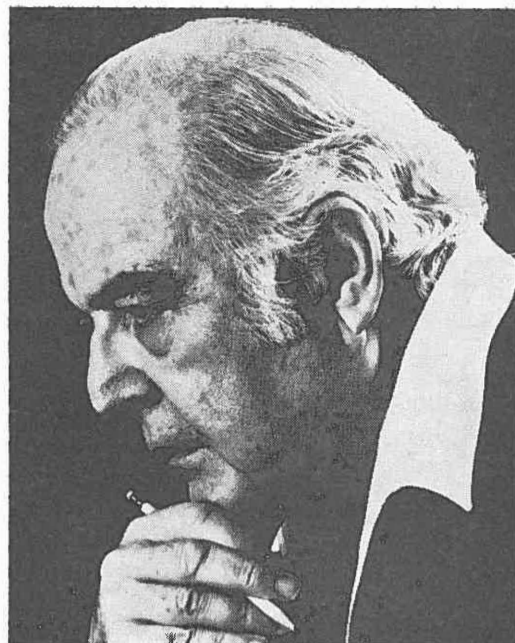

The American composer **Samuel Barber** died at his 5th Avenue apartment in New York City on Jan. 23, of cancer. He was 70. He had been ill since 1978 and was hospitalized until the week before his death.

Mr. Barber was born Mar. 9, 1910, in West Chester, PA, into a musical family; his aunt was the famous singer Louise Homer. He began piano study at the age of 6 and wrote his first composition at 7. He was also organist for a local church until he entered the newly-formed Curtis Institute in Philadelphia in 1924, where he studied composition with Rosario Scalero. He spent extended periods of time in Europe from 1928 on, winning the Prix de Rome in 1935, and a Pulitzer Traveling Scholarship the next year. He also won a Guggenheim award in 1946 and was elected to the American Academy of Arts and Letters. He was frequently associated with his fellow composer and librettist, Gian Carlo Menotti, with whom he shared a house called "Capricorn" in Mt. Kisco, NY, for 30 years.

The first work to bring Samuel Barber public acclaim was his "Overture to The School for Scandal" of 1933, while his most frequently-performed piece was the "Adagio for Strings," dating from 1938. His opera "Vanessa" was successfully staged by the Metropolitan Opera in 1958, but that house's subsequent commission of "Anthony and Cleopatra" for the 1966 opening of the new building at Lincoln Center was generally considered less successful. Among his other noted compositions are "Knoxville: Summer of 1915" (1947), "Hermit Songs" (1953), and "Prayers of Kierkegaard" (1954). His organ works are William Strickland's arrangement of the "Adagio for Strings," his own arrangement of a "Chorale Prelude on 'Silent Night' from 'Die Natali,'" "Variations on 'Wondrous Love'" (1958), and "Toccata Festiva" for organ and orchestra (written for the opening of the new organ at the Philadelphia Academy of Music in 1960 and first performed there by Paul Callaway and the Philadelphia Orchestra under the direction of Eugene Ormandy), all published by G. Schirmer.

The funeral was held on Jan. 25 in West Chester. A memorial service was held Feb. 9 at St. Bartholomew's Church in New York City, with works of the composer sung by the choir under the direction of Jack H. Ossewaarde; also participating were Ransom Wilson, Leontyne Price, Rosalind Elias, and John Browning.

West Coast Tracker Pioneer

The West Coast revival of mechanical-action organs — their construction and their importation — has been the subject of a recent article and correspondence in *The Diapason*. That there is something tangible to discuss and sufficient numbers to debate rival lists of favorite instruments is a salutary development, especially considering the state of the art when I settled on the West Coast some 15 years ago.

Regarding tracker-building workshops, I think it was a serious lacuna to have omitted the firm in which the West Coast tracker-building revival began, Abbott and Sieker of Los Angeles. In 1966 they supplied the Music Department of UCLA with a four-stop tracker positive and constructed the following year an encased two-manual and pedal tracker, at first a shop project then sold to a local Presbyterian church. (See Orpha Ochse, *History of the Organ in the U. S.*, p. 416 and Uwe Pape, *The Tracker Revival in America*, p. 135.)

From these beginnings to the instrument pictured on the cover of the Dec. 1980 issue of *The Diapason*, they have built trackers, although not exclusively, for churches, universities, and private residences.

Partner Uwe (Pete) Sieker is a direct link with modern German tracker construction, having apprenticed with Rother of Hamburg and having worked for Beckerath and Becker before emigrating to this country.

To sharpen the point, it can be added that Abbott and Sieker were successfully convincing churches to order mechanical action organs here in Southern California before the current generation of younger builders (the "Wunderkinder" of John Hamilton's article) here on the Coast were beginning their apprenticeships.

Sincerely,

Kenneth Herman
San Diego State University
San Diego, CA

Letters to the Editor

Points Raised on Schlick

This letter is in response to the first article in the November 1980 issue — "The German Organ of the Early Renaissance as Reflected in the 'Spiegel' of Arnolt Schlick." The article's author does not mention the Bärenreiter edition of the work, edited by Ernest Flade, 1951. In this modern edition, Schlick's work is presented in 20th-century German. In the editor's preface the case of Schlick's blindness is discussed. Flade suggests that it was most likely the result of an accident or disease in later life. He buttresses this assumption with a quotation from a letter by Schlick's son to his father: "Be not saddened that misfortune has taken your vision." The editor also reasons that Schlick's extensive travels in Germany and The Netherlands, as well as his descriptions of the organ, its parts, and its complicated construction, speak against blindness from birth.

The article on Arnolt Schlick in MGG (XI, 1817-20) by Karen Berg-Kotterba, also casts doubt on Schlick being blind from birth. The quotation from Schlick's son is repeated here.

However, MGG also mentions a servant's report to the municipal secretary of Frankfurt. This concerned the festivities for the coronation of Emperor Maximilian I in the cathedral of Frankfurt, Germany, in 1486. The servant recorded that a blind man, who was in the service of the Elector Palatinate, played the organ. It is known that Schlick was in his employ; however Schlick was not mentioned by name, and there could have been more than one organist in the emperor's employment.

A rather thought-provoking piece of information is given at the beginning of the Ernst Flade edition of the "Spiegel." He informs the reader about the
(Continued, page 10)

Music for Voices and Organ

by James McCray

Music for Children's Voices

Although W. C. Fields strongly felt that it was inviting disaster to appear in public with animals or children, he frequently did so with considerable success. Performing with children in choral situations is enjoying a renewed interest and conductors are finding that it results in much more success than disaster. Children's choirs are not exclusively found in churches or schools, but also are organized as community groups and exist in various cities around the country. Unlike the boy-choir tradition, the children's choir almost always refers to having both boys and girls singing, with an emphasis on the treble register.

Choosing music for these groups has special problems. In addition to the limited voice ranges, the maturity of the children often creates an issue regarding the appropriateness of the texts. Too frequently we hear children performing music that they undoubtedly do not understand, or, music that is too trite for them. Compared to other types of choirs, there is less available repertoire, so finding suitable music for them is usually more difficult. Just because a work is in unison or two parts does not immediately qualify it for children.

Another area of concern is that the person in charge of children's choirs, particularly in churches, often has no special training for that position. In fact, it is all too rare that these directors have professional knowledge about children's voices or repertoire; often they are volunteers in the church, with some general background in music. This is unfortunate, because the potential exists to do more harm than good for the children at this impressionable age.

In thinking about this article, a hasty review was made through the more than 25 choral training manuals in my personal library. The attention given to training children's voices is almost void. Oh yes, there are a few comments given to this level, but they are little more than token remarks. Does this suggest that those writing such books are not concerned about children's voices (choirs)? Not necessarily, yet this writer offers a recommendation that future books on working with choirs should devote more space to this neglected area.

The reviews this month feature works which may be performed by children's voices. Some are for children alone; some feature children with an adult choir. Most are suitable for church performances.

Oh, God, Invent a Word for Us. Ron Nelson; SAB adult chorus, 2-part children's chorus and organ; Boosey and Hawkes, 6025, \$1.00 (M-).

This work is unusual, in that it is intended that it be performed as a semi-dramatic presentation with interaction between the children and adults. There are dialogue areas that occur above organ music, and stage direc-

tions are provided (choir members are startled, etc.). The music is sweet and flowing with the emphasis on the children. Some areas are repeated and both choirs perform alone as well as simultaneously. The organ part is easy and on two staves, so it could be played on piano. This five-minute work is utterly charming and most highly recommended. It is a guaranteed winner with the performers and the congregation.

Four Anthems for Young Choirs. Ron Nelson; mostly unison with organ or piano; Boosey and Hawkes, 5576, 75¢ (E).

These three-page anthems are over 15 years old, but retain their freshness and continue to be one of Nelson's most frequently performed works. The first piece treats the theme as a three-part canon, but most harmonic vocal writing moves in parallel thirds for the young voices. The keyboard part provides a good background and is usually independent of the vocal lines. The writing is lyrical with limited ranges. These popular anthems work very well and are a real bargain for small budgets. Highly recommended.

Remember Your Creator. Samuel Adler; unison choir with percussion instruments and piano; Choristers Guild, A-103, 35¢ (M).

The children sing, clap, and stamp feet. Percussion instruments used include triangle, cymbals, drums, and tambourine, but Adler suggests that others could be added. The piano part is moderately busy and will require someone with facility to play it at the fast pace intended. The vocal lines are quite tuneful with a few skips in them. This is a delightful work based on Ecclesiastes and would be of interest to church, school, or city choirs. Effective and useful music.

Unless You Become. Alexander Pelouquin; children's choir, congregation, unison, 2 or 4-voice choir, flutes, trumpets, trombones, string bass, glockenspiel, bells, timpani, percussion, and organ or piano; G.I.A. Publications Inc., G-2311, \$3.00 (M+).

There are 16 movements in this 60-page work which is subtitled, *A Liturgy for Children*. It is intended for dramatic realization of the music with children carrying colorful streamers in the processional and areas appropriate for dance. Movements include texts about the Beatitudes, for offertory, communion, and other phases of the liturgy. Commissioned for the International Year of the Child in 1979, this celebrative work has some narration and is composed so that the chil-

dren are consistently involved, yet their musical parts are not particularly difficult. Some of the choral writing for the adult choir employs double choir, and while not taxing, it will require work. This is a very happy liturgy with music that will be enjoyed and appreciated. For those churches wanting to have a complete liturgy involving children this is a most useful new work. It is something that will probably be performed year after year.

I Will Give Thanks. Michael Jothan; unison, piano, and optional flute; Beckenhorst Press, Inc., BP 1101, 50¢ (M-).

There are two contrasting ideas which alternate throughout in this joyful anthem. The flute is used only on the last section and a separate part is provided on the back cover. The keyboard part is chordal, with doubling of the vocal line. Jothan uses a staccato, dance-like theme that is easily remembered and learned by the children. A cheerful piece that is recommended for beginning and intermediate voices.

How Precious to Me. Virgil T. Ford; 2-part with keyboard; H. W. Gray Publications (Belwin Mills), CMR 3350, 35¢ (E).

This piece is slow and sentimental in style. The voice lines are syllabic but no special vocal classification is designated. The ranges are the same and the lines are interchangeable, with a flowing accompaniment that generally doubles the voices.

In Peace and Joy I Now Depart. Donald Busarow; SATB with junior choir; Concordia Publishing House, 98-2346, 35¢ (M).

The children are used only in the second verse of an ABA format. Their line is a broad melody that soars above the homophonic chorus moving in a pulsating contrasting rhythm. The music is mildly dissonant and very attractive. This unaccompanied anthem provides a good opportunity to bring the children's choir into the adult choir for a special service, but it will not require excessive rehearsals.

Christmas Dance of the Shepherds. Zoltan Kodaly; SA with piccolo obbligato; European-American Music Corp., U 10878 NJ, 45¢ (M+).

There are several short vocal areas which are repeated and alternated throughout. The piccolo part is ornamented and used only half of the time. The vocal lines are not especially hard, although the altos need to be able to sing an A below middle C. A good choir will be needed to perform this lively and joyous Christmas work.

Can My Life Make A Difference? Sib Ellis; unison with optional 2-part and keyboard; Hope Publishing Co., JR 212, 40¢ (E).

There are two verses and a closing section in this rhythmically-syncopated three-page anthem. The keyboard part, especially, has a jazz quality. The vocal lines are easy with the optional part in small notes as an added harmony. It is suitable for use in church, although the text is not necessarily a religious one.

Sing and Dance, Children of God. Michael Bedford; 2-part and keyboard; Hinshaw Music Co., HMC-379, 50¢ (M-).

The first part may be sung with the choir in two halves, each having a part, or together in unison. The real two-

part writing occurs at the end and has some counterpoint. The keyboard part is a rhythmic background for the singing. If played on organ, the pedal part is specified in certain places. The middle section, in minor, is slower and more sustained. This anthem would work well with most children's choirs.

Children Sing, Chime and Ring. Dorothy Elder; children's voices and Orff-type instruments; Sacred Music Press, CSCR-11, \$5.95 (E).

This is a collection of service music for children's choirs, bells, and percussion. Designed as a leader's manual, a single copy can provide ideas and simple music for the entire year. It contains 32 pages of brief songs and simple accompaniments which could be taught by rote to pre-reading children. Dale Wood edited this excellent resource manual for easy and quick material suitable for children's choirs.

Fancie. Benjamin Britten; unison and piano; Boosey and Hawkes, 5611, 45¢ (M-).

The voices eventually divide into three-part chords which are dissonant. The music is light and fast in Britten's setting of the Shakespeare text. There are wide dynamic contrasts, delicate articulations, and a moderately high tessitura. The piano writing is busy and has running eighth notes in the left hand throughout. This secular work is ideal for school or semi-professional groups.

The Lamb. John B. Younger; 2-part and keyboard; Frederick Harris Music Co., HC 2001, 25¢ (E).

The piano doubles the voices in this setting of Blake's famous poem. Using gentle harmonies and repeated material, Younger's setting could be sung in unison or by less advanced groups just learning to sing in parts.

Little Things at Christmas. Joyce Merman; unison with keyboard and optional flute; Harold Flammer of Shawnee Press, E-5211, \$2.50 (E).

There are five songs in this child's view of Christmas. Brief narration is provided as a link between movements, although these pieces could be performed separately as anthems. Some of the movements have optional percussion and handbell parts which are available separately from the publisher. The five movements are *Still is the World in December*, *Small Sounds*, *The Least at the Manger*, *Little Things at Christmas* and *The Children's Christmas Prayer*. These attractive little pieces are recommended for church groups and are simple but very useable.

A Day in a Life. Keith Swanwick & Patrick Lee; unison voice and piano with optional instruments; Oxford University Press, \$9.75 (M+).

Based on Solzhenitsyn's *One Day in the Life of Ivan Denisovich*, the work may be performed as a choral work or staged as a dramatic presentation. Stage directions are given in the foreword. The work is about 30 minutes long and has areas for solo voices. The keyboard part has some tricky moments, with the music for the extra instruments written in this vocal score. There are mixed meters, some dissonance, and some songs with several verses. The music is moderately sophisticated, with content such that a mature group of performers will be needed. This advanced piece is highly recommended to those choirs seeking a challenge and something above the normal fare.

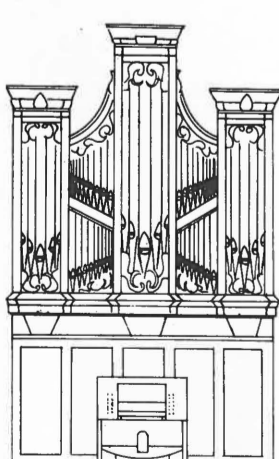

PHILLIPS ACADEMY
announces an
ORGAN DEDICATION WEEK END
celebrating the installation
of two new instruments built by
Andover Organ Company
May 22-24, 1981

FRIDAY EVENING RECITAL - Jarek Paukert
SATURDAY SEMINARS - James Darting
Daniel Pinkham
Elizabeth Sollenberger

FOR FURTHER INFORMATION Write:
Organ Dedication Week End
PHILLIPS ACADEMY, ANDOVER, MA 01810

The most monumental musical reference work in the world

The New Grove Dictionary of Music & Musicians supersedes all existing music encyclopedias. Its 20 volumes, its 18,000 pages, provide the most comprehensive and detailed coverage of music ever published. A completely new work and not a mere updating of a former edition, *The New Grove* represents an investment of over \$7 million and is the culmination of 12 years' planning, writing, and editing by 2,400 distinguished musicologists from 70 countries.

Lucidly, with meticulous scholarship, *The New Grove* not only presents the most current appraisals of the lives and works of the men and women who created music, who wrote it, performed it, conducted it, or in some way affected its development, but, in addition, the new Dictionary hugely expands its treatment of every other facet of music.



There are nearly 1 million words about musical forms. Nearly 1 million words about instruments. Well over 1 million words about non-Western, folk, jazz, and popular music.

For the first time in *Grove*, American music is accorded exactly the sort of recognition formerly reserved for European music and traditions.

Grove's studies of ancient, medieval, and renaissance music comprise some 3,500 new entries, including material on poet-musicians, composers, chroniclers, liturgical rites, styles and genres, and an especially significant article on plainchant.

Like virtually everything else in *The New Grove*, these all reflect scholarly advances made since *Grove* last appeared, a generation ago.

Whether you're involved professionally or as a devoted amateur, you'll find that your pleasure in music—and your exact knowledge of it—cannot help but be enhanced by *The New Grove*. It is indispensable, not only for the articles just described, but also for *Grove's* new pieces on performing practices, on theory, terminology, acoustics, the psychology of music, the musical traditions of cities... as well as for the Dictionary's exhaustive new bibliographies and lists of composers' works.

And all of this—all the 22 million words of *Grove*—is astutely augmented by over 3,000 musical examples and over 4,500 photographs and illustrations.

The New Grove. There's never been a musical reference work like it. Owning it is like having permanent access to one of the world's great music libraries. It is a work to use—and savor—for a lifetime.

Free Prospectus—and a \$200 saving

To tell you more about *The New Grove*, we've prepared an elegant, FREE *Prospectus*. It is yours for the asking. Profusely illustrated, the *Prospectus* describes *The New Grove* in detail and reveals how you may acquire it without financial risk—and at a saving of \$200. As this is a limited-time offer, available only from the publisher, we urge you to send for your free *Prospectus* today. **To speed your request, call us toll-free: (800) 424-5112. In Washington, D.C.: 737-0034.**

"...it is a triumph of contemporary musicology...the most ambitious and comprehensive musical dictionary and encyclopedia ever attempted...a brilliant success!" HAROLD C. SCHONBERG, THE NEW YORK TIMES

"...a great event!" TIME

"A musical event of high importance....Any volume I take up, I find hard to put down again!" ANDREW PORTER, THE NEW YORKER

"...an obviously great and very significant contribution to our cultural life!" LEONARD BERNSTEIN

20 VOLUMES—22,500 ENTRIES

**The New Grove
Dictionary of Music & Musicians**

1283 National Press Building / Washington, D.C. 20045

Yes, please send me a free *New Grove Prospectus*.

Name _____

Address _____

City _____ State _____ Zip _____ D-1

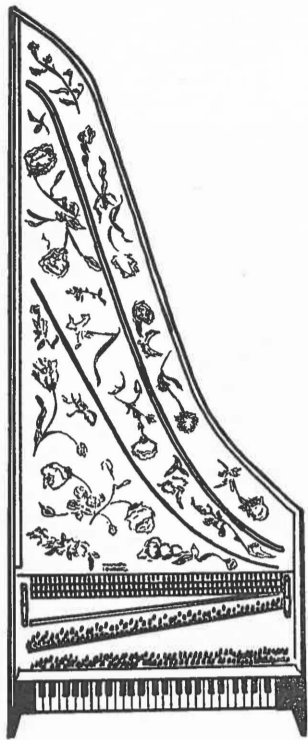

Harpsichord News

Recitals

Mark Brombaugh and Lynn Edwards played this program of music for harpsichord and pedal harpsichord for the Community Concerts of Burnt Hills, NY, on Oct. 19: Toccata in D minor, S. 538, Trio Sonata in C minor, S. 526, Suite in G, S. 816, Concerto in C for Two Harpsichords, S. 1061, J. S. Bach; Praeludium in G minor, BuxWV 163, Suite in C, Praeludium in A minor, Buxtehude.

Darlene Catello played this recital at the University of Notre Dame on Feb. 15: Ordre 2, F. Couperin; Toccata in D, S. 912, Bach; Toccata X, Canzon IX "La Querina," Frescobaldi; Tombeau Chambonnières, d'Anglebert; Sonatas K. 430, 426, 450, Scarlatti. The harpsichord: a French double by Willard Martin, 1980.

Harold Chaney played this program at Trinity Cathedral, Trenton, NJ, on Mar. 1: Rondo alla Turca (Sonata in A), Mozart; Passacaglia, Fischer; "French" Suite in E, Toccata in D, Bach; Three Pieces from Mikrokosmos, Bartok; Partita (1954), Halsey Stevens; four sonatas, Scarlatti. The harpsichord: Pleyel, Paris.

Lynn Edwards and Edward Pepe played music for one or two harpsichords and clavichords at Corpus Christi Church, New York City, on Dec. 7: Toccata in F, S. 540, Bach; Sonata in F, W. F. Bach; Intabulations from the Tabulaturbuch of Bernhard Schmid the Elder; Sonata IV in A, C. P. E. Bach; Praeludium in G minor, Buxtehude; Sonata in G, J. C. Bach; Trio V in C, S. 529, J. S. Bach.

Kenneth Gilbert played two recitals at Florida State University, Tallahassee, on Nov. 7 and 21, and a recital for the University Musical Society of the University of Michigan, Ann Arbor, on Nov. 15. Works heard on these programs included: Prélude non mesuré, Sarabande grave, Chaconne, d'Angelbert; Ordre 17, Passacaille in B minor, F. Couperin; Suite from Les Indes Galantes, Suite in E minor, Rameau; "English" Suite in F, J. S. Bach; Passacaille in C, Louis Couperin; Ouverture, Sarabande, Passacaille, Handel; La Felix, Chaconne, Duphy; A New Ground, Hornpipe, Purcell; and three Sonatas, Scarlatti. In Florida Mr. Gilbert played a French double harpsichord by William Dowd; in Ann Arbor, a 1980 French double harpsichord by Willard Martin.

Laurette Goldberg gave a recital for the Los Angeles Bach Festival on Mar. 6 at First Congregational Church. On Mar. 7 she conducted a seminar on Bach's Well-Tempered Clavier.

Bruce Gustafson, St. Mary's College, Notre Dame, IN, played this faculty recital on Jan. 22: Suite in C, Louis Couperin; Partita in G, S. 829, Bach; Ordre 7, Francois Couperin; Toccata VII, Michelangelo Rossi; Sonatas K. 517, 492, Scarlatti. The harpsichord: a French double by Willard Martin, 1980.

Martin Haselböck, Vienna, was the harpsichordist in the first Viennese performance and radio production of Anton Heiller's Concerto for Harpsichord, Organ and Orchestra (commissioned by the Dallas Chapter, AGO, for the 1972 National AGO Convention). The concert took place in the Great Hall of the Wiener Konzerthaus. Hans Haselböck was organist and Erich Bergel conducted the ORF-Symphony Orchestra. The harpsichord: a French double by Willard Martin.

Alfreda Hays, Summit, NJ, played the dedication recital on a new Hubbard kit harpsichord at St. John's Lutheran Church in Summit on Feb. 15; "From the Court of Elizabeth I of England," works by Byrd, Dowland, Farnaby, Peerson, and My Lady Carey's Dompe, plus A Fancy for Two to Play (Tomkins) with Wayne Dieterick; "From the Court of Louis XIV of France," works of Chambonnières, Louis Couperin, Marchand, and Elisabeth Jacquet de la Guerre; "From the Court of the Margrave Ludwig of Baden," Suite 7 (Terpsichore) by Fischer; and Gagliarda Seconda, Corrente Seconda, Frescobaldi; Sonata 23, Cimarosa; Sonata in D, Mateo Albeniz.

Margaret Irwin-Brandon, Mount Holyoke College, South Hadley, MA, played three recitals at the college on Oct. 28, Nov. 4, and Nov. 11. The programs included: Ordre 6, Couperin; All in a Garden Green, Byrd; Fantasia, Munday; Suite 5, Forqueray; Toccata in D, S. 912, Bach; Fantasia, Morley; Toccata V, Rossi; Capriccio sopra ut re mi fa sol la, Toccata VII, Bk. II, Frescobaldi; Toccata del Secondo Tono, Sonata Cromatica, Merula; Suite in A, Rameau; Sonatas in A, Scarlatti; Fantasia on Tone V, Bull; Capriccetto sopra il cu-cu, Poglietti; Ordre 4, Couperin; Le Rossignol, Philips; Fantasia, Farnaby.

Igor Kipnis played this program at Mountain View College, Dallas, on Feb. 22: Prelude, Fugue and Allegro, S. 998, "French" Suite in G, S. 816, Chromatic Fantasy and Fugue, S. 903, J. S. Bach; Nine Sonatas, Soler. The harpsichord: a French double by Richard Kingston.

Janina Kuzma played this program at the Cleveland Museum of Art on Jan. 25: Aria with Thirty Variations (Goldberg Variations), S. 988, J. S. Bach.

Karyl Louwenaar, Florida State University, Tallahassee, played programs in north Germany, at the Ringve Museum, Trondheim, Norway, and at the Vleeshuis Museum, Antwerp, during the fall. She played this recital at the Phillips Collection, Washington, D.C. on Feb. 15 and at the University of South Carolina on Feb. 24: Sonatas, K. 132, 133, Scarlatti;

Partita in E minor, S. 830, Bach; Le Rappel des Oiseaux, L'Entretien des Muses, Les Cyclopes, Rameau; Cianna (1979), Harold Schiffman; Fantasy for Solo Harpsichord (1973, revised (1975), William Penn.

Marilyn Mason, University of Michigan, was joined by violinist **Pierre D'Archangeau** for two recitals at Carnegie Recital Hall, New York City, on Dec. 5 and 12: Sonatas in C minor, E Major, F minor, A Major, B minor, and G Major, J. S. Bach; Sonatas in A Major, G minor, A Major, D Major and E Major, Handel. The harpsichord: a French double by Willard Martin, 1980.

Edward Parmentier, University of Michigan, played this recital at the Florida State University, Tallahassee, on Jan. 11: Pavan and Galliard Sir William Petre, Byrd; Diferencias sobre el canto llano del Caballero, Cabezón; Toccata and Galliard, Cabanilles; Pieces in D, Louis Couperin; Preludes and Fugues in F-sharp Major and minor, WTC II, Chromatic Fantasy and Fugue, S. 903, Bach; Sonatas, K. 177, 145, Scarlatti.

Larry Palmer, Southern Methodist University, was joined by guitarist **Eric Madriguera** for this concert for the Kerrville, Texas, Community Concert Association on Jan. 22: Adagio in G, Toccata in G, Bach; three pieces from Lambert's Clavichord, Howells; Introduction and Fandango, Boccherini; Sonata in G minor, Vivaldi; Popular Spanish Songs, de Falla (transcribed for guitar and harpsichord by the artists). The harpsichord: a French double by William Dowd, 1968. Mr. Palmer was joined by soprano **Lynda Poston-Smith** for this program at the School of Church Music, Southwestern Baptist Seminary, Fort Worth, on Feb. 6: Eight Preludes, L'Art de Toucher le Clavecin, Seconde Leçon de Tenèbre, F. Couperin; Suite from the Opera Les Indes Galantes, Rameau. The harpsichord: a French double by Richard Kingston. For the Galveston Chapter, AGO, Mr. Palmer played these harpsichord works on Mar. 13: Les Indes Galantes, Rameau; Three Little Preludes, opus 35, Kurt Hessenberg; Chromatic Fantasy and Fugue, S. 903, Bach. The harpsichord: a French single manual by William Dowd, 1979.

Virginia Pleasants, London, has been appointed visiting lecturer in fortepiano and harpsichord at Cambridge University.

Rafael Puyana played the six Bach Partitas on two programs at St. Johns Smith Square, London, on Feb. 16 and 18.

Richard Rephann, Yale University, played a recital of French harpsichord music in the Keyboard Instrument Gallery of the Yale University Collection of Musical Instruments on Dec. 7. Music by Louis and Francois Couperin, Antoine Forqueray, and Rameau was heard on two Pascal Taskin instruments from the collection: a two-manual harpsichord of 1770 and a small octave spinet dated 1778. Restoration of the épinette was completed in October, and this concert marked its modern-day debut.

Scott Ross, LaValle University, Québec, played the "Goldberg" Variations (Bach) for the Southeastern Historical Keyboard Society meeting

at the University of Georgia on Feb. 26, substituting for an ailing Ralph Kirkpatrick. On Feb. 27 **George Lucktenberg**, **Karyl Louwenaar**, and **Egbert Ennulat** presented a program of music for two and three harpsichords, including the Bach Concerti in D minor and C Major for three and the Concerto in C for two harpsichords, and V. Mahscheck's Concerto in D Major for three harpsichords and winds (first modern performance).

Joan Schuitema played this graduate recital at Southern Methodist University, Dallas, on Mar. 21: Passacaglia in D minor, Fischer; Preludes and Fugues in B-flat Major and minor, WTC I, Bach; Suite from Les Indes Galantes, Rameau; three pieces from Lambert's Clavichord, Howells; Canciones de Galpe, R. Bedford Watkins (dedicated to Joan Schuitema; first performance). The harpsichord: a French double by Richard Kingston.

The Artist Series of the Harpsichord Center, Los Angeles, presents concerts on the second Saturday of each month, with the concert usually repeated on Sunday afternoon. In its series for 1980-81, the Center has presented: **Eileen Anderson** (Pieces in D, L. Couperin; Ordre 28, F. Couperin; Sonata 54, Haydn; Partita 6, Bach); **Antony Brazier**, baroque flute and **William Neil Roberts**, harpsichord (works of Blavet, Handel, early 16th-century English and Italian keyboard music); **Mary Jane Newman** (lecture-recital, works of J. S. Bach); **James Bonn** (clavichord recital: works of Froberger, Poglietti, Muthel, J. S. and C. P. E. Bach); **William Neil Roberts**; **Richard Rephann**; and **Edward Parmentier**.

The Early Music Centre of London presented a varied program for its Festival 1980 (Sept. 28-Oct. 4). In Wigmore Hall the English Concert, directed from the harpsichord by **Trevor Pinnock**, gave a program including Bach's Brandenburg Concerto V; the New London Consort's program consisted of music from 14th and early 15th-century Italy; **Wieland Kuijken** and **Colin Tilney** played music for viola da gamba and harpsichord; **Paul O'Dette** and **Christopher Wilson** presented Italian and English lute duets and solos; the Musica Antiqua of Cologne with **Henk Bouman**, harpsichord, presented music by Rosenmüller, Reincken, Buxtehude, Pachelbel, Vivaldi, Schmelzer, and Biber; and the Musica Antiqua of London gave a program of "Music in Italy in 1500: Josquin, Isaac, Tromboncino, Cara, and Millias." The Festival concluded in Queen Elizabeth Hall with the Taverner Choir and Players presenting Haydn's Symphony 60 and Mozart's Mass in C minor, K. 427, conducted by Andrew Parrott.

Also in London, Peter Maxwell Davies' The Fires of London included Elliott Carter's Sonata for harpsichord, oboe, flute, and 'cello in its program in Queen Elizabeth Hall on Jan. 31.

Builders

Eric Herz Harpsichords, Inc., 12 Howard Street, Cambridge, MA 02139 announce the production of a German single manual harpsichord. With the "double bentside" associated with the Hamburg school of harpsichord making, a dimension of just under seven feet by three feet, a range from GG

(Continued, page 8)

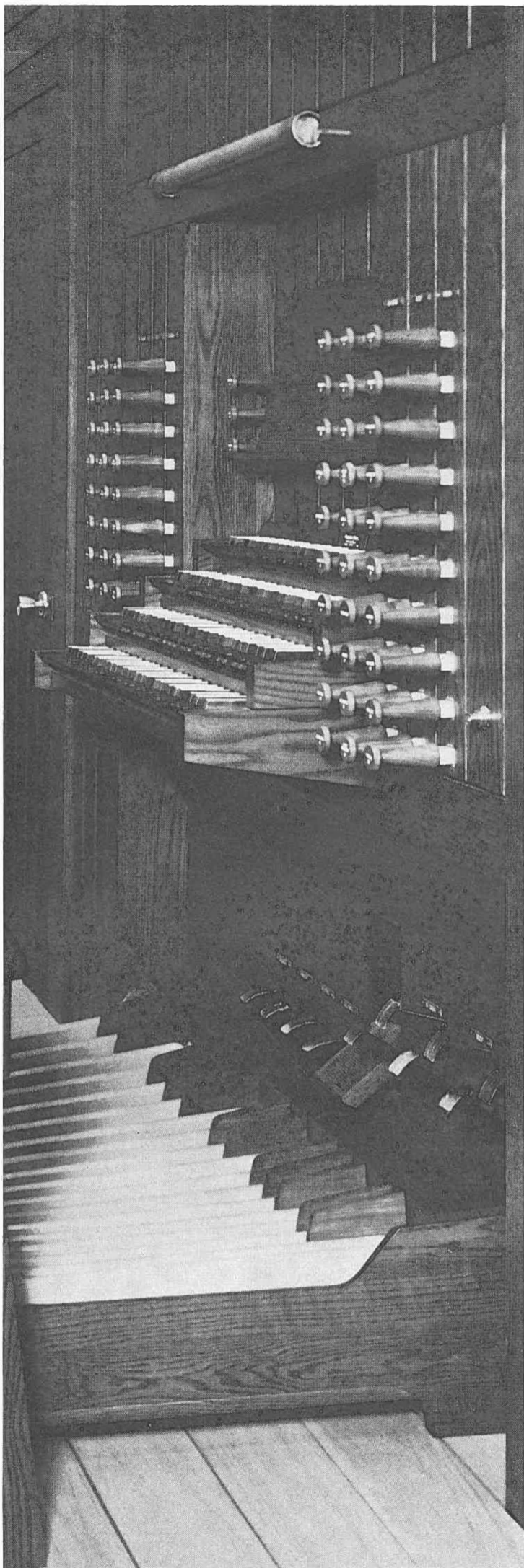

THE CONCERT HALL VICTORIAN ARTS CENTRE MELBOURNE, AUSTRALIA

GRAND ORGUE

1. Montre	16
2. Montre	8
3. Flûte à cheminée	8
4. Prestant	4
5. Grosse tierce	3-1/5
6. Nasard	2-2/3
7. Doublette	2
8. Quarte de nasard	2
9. Tierce	1-3/5
10. Cornet	V
11. Fourniture	VI
12. Cymbale	IV
13. Bombarde	16
14. Trompette	8
15. Voix humaine	8
16. Clairon	4

POSITIF

17. Bourdon	16
18. Montre	8
19. Bourdon	8
20. Prestant	4
21. Flûte	4
22. Nasard	2-2/3
23. Doublette	2
24. Quarte de nasard	2
25. Tierce	1-3/5
26. Larigot	1-1/3
27. Fourniture	V
28. Trompette	8
29. Cromorne	8
30. Clairon	4
Tremblant	

RÉCIT

31. Bourdon	16
32. Principal	8
33. Bourdon	8
34. Viole de gambe	8
35. Voix céleste	8
36. Octave	4
37. Flûte octaviante	4
38. Octavin	2
39. Plein jeu	VI
40. Basson	16
41. Trompette	8
42. Hautbois	8
43. Clairon	4
Tremblant	

ECHO

44. Bourdon	8
45. Flûte	4
46. Nasard	2-2/3
47. Quarte de nasard	2
48. Tierce	1-3/5
49. Trompette	8

PÉDALE

50. Montre	32
51. Montre	16
52. Soubasse	16
53. Octavebasse	8
54. Flûte	8
55. Octave	4
56. Flûte	2
57. Fourniture	VI
58. Bombarde	16
59. Trompette	8
60. Clairon	4

Mechanical key and stop action

Four reversible coupler pedals

Three mechanical combination pedals with cancels

Manual compass 56 notes. Pedal compass 30 notes

Interchangeable pedal claviars

Casavant Frères
LIMITÉE

C.P. 38, ST-HYACINTHE, QUÉBEC, CANADA

Those attending the McGill Symposium are cordially invited to visit our factory in St.Hyacinthe on Friday, May 29th, 1981, to hear and play this instrument. Chartered buses and lunch will be provided.

MARIE-CLAIRE ALAIN
returns to
Colorado State University

For information, write

Robert Cavarra
Department of Music
Colorado State University
Fort Collins, CO 80523

Mechanical-action organs by Casavant (North German) and Phelps (French Classic)



1981 Summer Workshop
Fort Collins, Colorado
August 9-16

Eighth Annual

Harpsichord
Workshop

at Seaver College/
Pepperdine University
Malibu, California

June 22 - June 28

Susanne Shapiro
Wm. Neil Roberts
Co-Directors

featuring for 1981
English Virginalists and
French composers during
the reign of Louis XIV

For more information write to:

Harpsichord Workshop
Attention: Shapiro-Roberts

2751 West Broadway
Los Angeles, CA 90041
Tel: (213) 254-9613

harpsichordist
Robert Edward Smith

pianist
Thomas Richner

classical guitarist
Giovanni DeChiaro

organists
Robert Clark
Nicholas Danby
Raymond Daveluy
Roberta Gary
Jean-Louis Gil
Robert Glasgow
Jean Guillou
Richard Heschke
August Humer
David Hurd
Nicolas Kynaston
Huw Lewis
Odile Pierre
McNeil Robinson
John Rose
Larry Smith
John Chappell Stowe
Gillian Weir

phillip truckenbrod
representative for concert artists

Box 14600
Barry Square Station
Hartford, CT 06114
(203) 728-1096

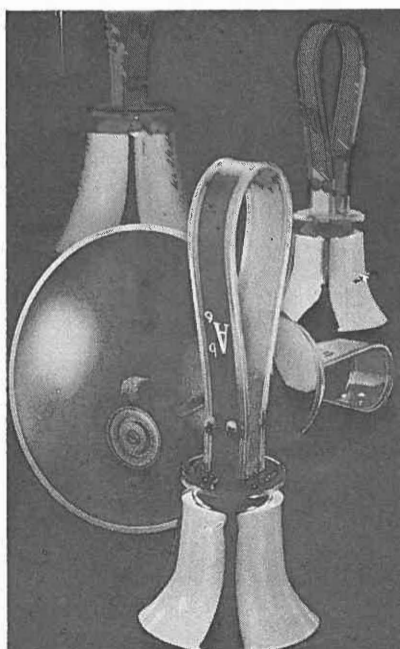

Malmark Handbells
the mark of
tonal excellence



For full information write or call:
Malmark, Inc. Dept. J
21 Bell Lane
New Britain, PA 18901
(215) 345-9343

Harpsichord News

(continued from p. 6)

to e''', and either two 8-foot stops or two 8-foot and one 4-foot stops, the new addition to the Herz catalog should be a popular choice.

Summer Events

Igor Kipnis will return to Indianapolis, IN for his 8th summer harpsichord workshop as part of the Festival Music Society summer program there. The two-week workshop (July 6-19) costs \$175, which includes two private lessons plus a group lesson each week. Applications should be sent to Frank Cooper, c/o Dade County Council of Arts and Sciences, Room 2004, Courthouse, 73 West Flagler St., Miami, FL 33101. Mr. Kipnis will make his debut playing a 1793 Graebner fortepiano on July 12, during the Festival.

Jane Clark will give a harpsichord workshop at Dartington, England, from July 25 to Aug. 1. The program will include general repertoire with special attention to Couperin and Scarlatti.

Kenneth Gilbert embarks on his usual peripatetic summer round according to the following schedule: July 19-25: Clisson, Semaines Internationales d'Art Classique Français, 26, rue Mellier, 44100 Nantes, France (Chambonnières suites, Marchand suites, Couperin 2e Livre, Bach WTK I); July 30-Aug. 8: Antwerp, Ruckers Genootschap, Museum Vleeshuis, B-2000 Antwerpen, Belgium (Purcell suites, Couperin 3e Livre, Bach English suites 2, 3, 4, one choice piece); Aug. 10-14: Siena, Accademia Chigiana, Siena, Italy (Bach Partitas, one choice piece of Froberger); Aug. 17-26: Annecy, Centre Musical International d'Annecy, 10 rue J.-J. Rousseau, 74000 Annecy, France (Free program); Sept. 7-12: Venice, Corsi di Musica Antica, Fondazione Giorgio Cini, Isola di San Giorgio Maggiore, 30124 Venezia, Italy (Couperin 3e Livre, Louis Couperin, one choice piece); Sept. 15-22: Daroca, Musica en Daroca, Sanclemente 22,4.iz, Zaragoza-1, Spain (d'Anglebert suites, Couperin 1er Livre, Bach French suites, one choice piece). For information on any of these workshops, contact the above addresses.

Publications

A fine article sure to be of interest to our readers, "Problems of Articulation in the Keyboard Music of the English Virginalists" by Janet Wright appeared in the Oct. 1980 issue of **Musical Opinion** (beginning at page 13).

Bach, the quarterly journal of the Riemenschneider Bach Institute, Baldwin-Wallace College, Berea, OH, includes in its Vol. XII, no. 1 for Jan. 1981, part II of Wesley K. Morgan's "Singet dem Herrn ein neues Lied: an Old Problem"; "More on the Figured-Bass Accompaniment in Bach's Time: Friedrich Erhard Niedt and The Musical Guide" by Alma Espinosa; "The Sources for Dryden's King Arthur" by William R. Hill; and, in facsimile, Contrapuncti I and II from Kunst der Fuge.

Early Music, Vol. 8, no. 4 (Oct. 1980) featured Sheridan Germann's fascinating "Monsieur Doublet and his Confrères: the Harpsichord Decorators of Paris, part I." Vol. 9, no. 1 (Jan. 1981) is largely devoted to the lute, but harpsichordists will treasure Evan Nordenfelt-Aberg's article "The Harpsichord in 18th-century Sweden," David Fuller's "An Unknown French Ornament Table from 1699," and Neal Zaslaw's review of Frederick Neumann's study of baroque ornamentation.

Boston in May

A major event in the early music world will be the **Boston Early Music Festival and Exhibition** from May 26-31. Exhibitions of early instruments by contemporary craftsmen throughout the world and "musical instruments in books and prints 1491-1931"; Ralph Kirkpatrick's fiftieth anniversary harpsichord concert, Wieland Kuijken, viola da gamba, and John Gibbons, harpsichord; a Venetian Festival with music by the Boston Camerata and the New York Cornet and Sacbut Ensemble; a fully-staged performance of Monteverdi's *The Coronation of Poppea*; plus lectures, panel discussions, and extra open hours for the musical instruments collection in the Boston Museum of Fine Arts promise a feast of sights and sounds. For further information, write Jon Aaron, Manager, 25 Huntington Avenue, Boston, MA 02116.

Features and news items for these pages are always welcome. Please address them to **Dr. Larry Palmer, Division of Music, Southern Methodist University, Dallas, TX 75275.**

Here & There

JOHNNYE EGNOT gave a lecture-demonstration on early Italian music for the Richmond AGO chapter on Jan. 13. The presentation took place at Ginter Park Presbyterian Church in the Virginia city.

Music by HEALEY WILLAN constituted a concert Oct. 12 at All Saints' Church in Pontiac, MI. Donald E. Renz conducted *Rise up, my love*; *O Sacred Feast*; *Hail, True Body*; *Missa Brevis 1*; and *Gloria Deo per immensa saecula*; on the organ he played *Introduction, Passacaglia, and Fugue in E-flat Minor* and three shorter works.

MARY LOU KALLINGER, organist at St. Luke's Episcopal Church in Ft. Collins, CO, presented a series of five 15-minute radio broadcasts of Advent and Christmas organ music during December on Denver station KVOD-FM. The programs were recorded on the 1974 French classic-style organ in the church, built by Lawrence Phelps.

WILLIAM FERRIS of Chicago has been nominated for a Pulitzer prize for his new work *Snowcarols*, first performed on Dec. 7. The composition is scored for soloists, chorus, and chamber orchestra, and will be published by Oxford University Press.

The eighteenth anniversary of the dedication of the large organ built by the late RUDOLPH VON BECKERATH at St. Paul's Cathedral in Pittsburgh was celebrated last Nov. 16 with a gala concert. Performers included organist Carlo Curley, soprano Li-Ping Hsieh, alto Beatrice Krebs, tenor David Dreher, and bass Milutin Lazich. The vocalists were heard in Beethoven's *Mass in C*, directed by Paul Koch.

Windows, after Mark Chagall, is a new composition for trumpet and organ by Czech composer Petr Eben (b. 1929). It was inspired by the Chagall stained glass in the Chapel of St. Anthony in Mainz, West Germany, where the work was performed last summer by David Tasa and Gert Angst.

The INTERNATIONAL BOY SINGERS FESTIVAL, held at the end of December in Saltillo, Mexico, included more girls than boys. Festival sponsors decided to admit girls' choirs and mixed children's choirs to the annual event but will retain the name "boy" in the title.

Elizabeth Szönyi's *Concerto for Organ and Orchestra*, premiered in Budapest in 1958, received its first U.S. performance last summer at Immanuel Presbyterian Church in Los Angeles. SAMUEL JOHN SWARTZ was the organ soloist, with John Alexander conducting the orchestra.

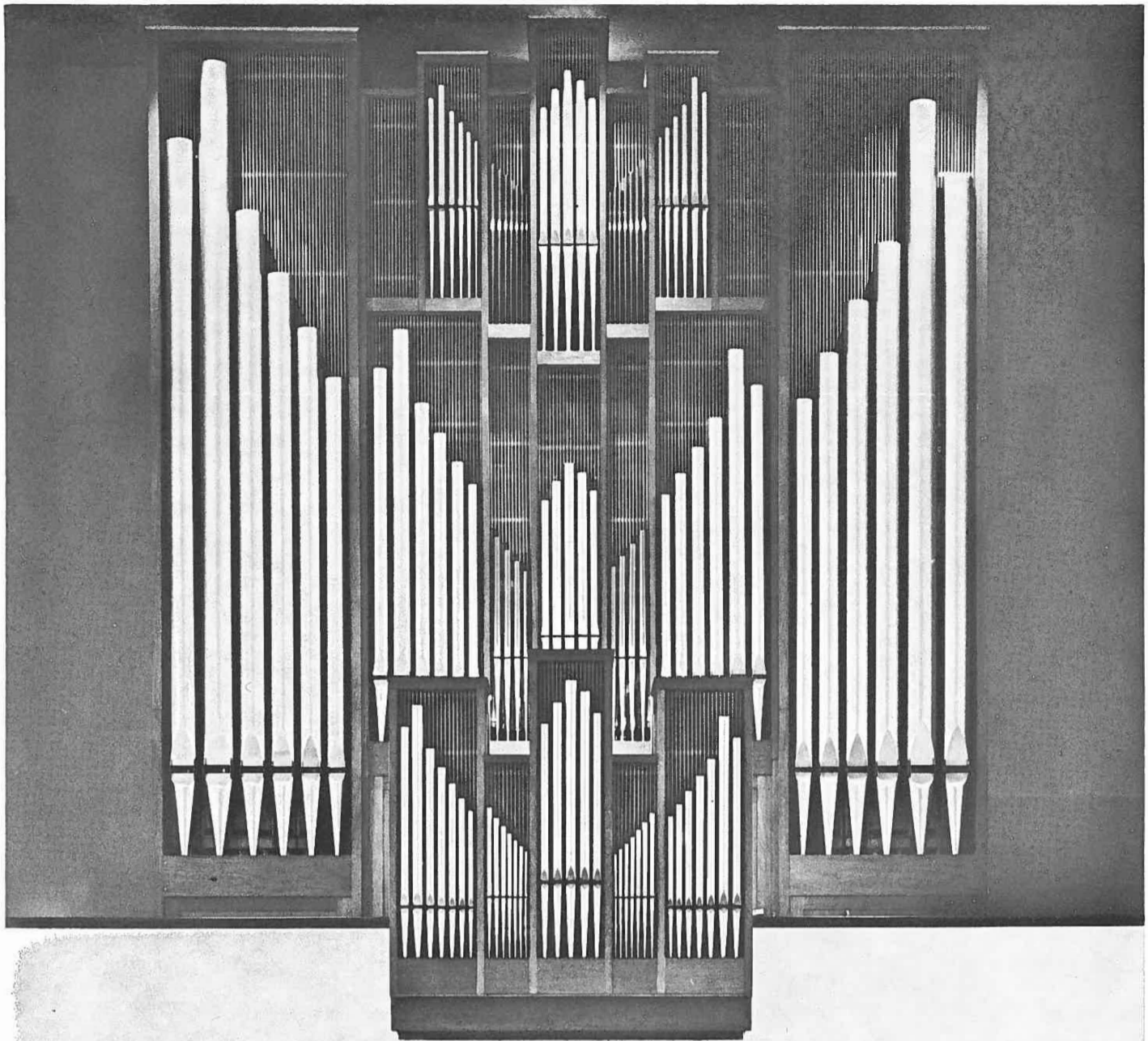

FIRST CHURCH OF CHRIST
CONGREGATIONAL
SUFFIELD, CONNECTICUT
3 MANUALS - 51 RANKS
MECHANICAL ACTION
OPTIONAL FLEXIBLE WIND

Gress · Miles

ORGAN COMPANY, INC.
PRINCETON, NEW JERSEY

MEMBER APOBA

NEW!

A
LITTLE
ORGAN
LEXICON

C. H. W. LINDOW
A LITTLE ORGAN LEXICON
FRENCH—GERMAN—ENGLISH
\$11.00

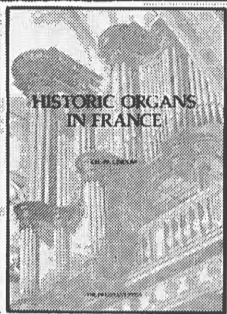

C. H. W. LINDOW:
HISTORIC ORGANS IN FRANCE
144 Pages, Illustrated \$21.00



BLANCHARD:
ORGANS OF OUR TIME
231 Pages, Illustrated \$17.50

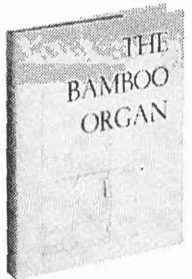

KLAIS: THE BAMBOO ORGAN
292 Pages, Illustrated \$30.00

CATHEDRAL ORGAN POSTERS
Berlin — Graz — Trier
16 1/2" x 23 1/2" 3 for \$7.00

Postpaid in U.S.A. when check
accompanies order
(Ohio residents add 5.5% sales tax)

THE PRAESTANT PRESS
P.O. Box 43
Delaware, Ohio 43015

Letters to the Editor

(continued from p. 3)

discovery of the only surviving copy of the treatise. It was found by a Saxonian village schoolmaster behind the chimney of a farm house, in the middle of the 19th century!

In reference to one statement in the article in *The Diapason*, p. 7, col. 1, paragraph 1 — the Double Octave in reference to a 16' Principal would be a stop of 4' pitch, not of 8' pitch. It would be the Octave, not the Double Octave, that would have 8' pitch.

Sincerely yours,

Isa Mc Ilwraith
Signal Mountain, TN

Jane Schatkin Hettrick, author of the November article, replies:

I am, of course, familiar with Ernst Flade's 1951 edition of Spiegel, along with Flade's 1932 edition, Paul Smets' 1937 edition, Franklin Miller's partial edition (1959-62), and the several other studies of Spiegel that have been done. Moreover, Karin Berg-Kotterba's article in the encyclopedia MGG served as a starting-off point for the years of research that led to my forthcoming edition of Spiegel (Institute of Mediaeval Music, Switzerland). My chief authority, however, remains the original text of Spiegel, which exists, incidentally, not in an "only surviving copy," but in two extant copies. Since Flade wrote about the first copy, now in the British Library in London, Werner Braun discovered another copy in the Marienbibliothek, in Halle.

The subject of my article was the content of Spiegel, not the life of Arnolt Schlick. Biographical details concerning Schlick's blindness, as Prof. Mc Ilwraith herself notes, have been repeatedly cited, in sources that are readily available to the modern reader. The quotation in which Schlick's son, Arnolt Schlick the Younger, alludes to his father's blindness appears in the preface to the elder Schlick's musical collection *Tabulaturen* (1512): "Sey nit betrübt / noch such rach / das dir das glück hengeno[m]men hat dein[en] euserlichen auge[n]." The wording of this sentence could be taken to suggest a later loss of vision, but it does not negate the possibility of congenital or very early blindness. Furthermore, Schlick traveled widely throughout his life, long after the time that his blindness is established beyond doubt. Therefore, to argue that his "extensive travels in Germany and the Netherlands" speak against blindness from birth is fallacious.

It is conceivable, although unlikely, that the servant's report of the blind man who played the organ at the coronation of the Emperor Maximilian I refers to a second blind organist who was also in the employ of the Elector Palatine. This "blind man at the organ" is identified as Schlick by the consensus of reliable Schlick scholars, including Berg-Kotterba, who describes this record (in MGG) as: "the first document referring to Schlick as organist that may be dated with certainty."

With reference to Prof. Mc Ilwraith's interpretation of the term "Double Octave," again one must know the original text of Spiegel and not assume that modern terminology may be applied. The passage in question reads: "Item vor das erst / die principalm. das etlich nenne[n] koppeln / oder fleytlen etc. Item ein octaff einer langen mesz. oder so das werck fast grosz wer ein doppel octaff" ("First the Principal, which some call Koppel or Flute; then a narrow scaled Octave, or, if the instrument is very large, a Double Octave"). The meaning of Double Octave in this context hinges on what Schlick intends by the expression "very large." As I indicated in my article, there are (at least) two ways to interpret Schlick's wording. If by "very large" Schlick refers to an instrument with a great number of ranks, then the Double Octave would represent an additional rank an octave above the Octave stop: a stop of 2' pitch in reference to an 8' Principal and a stop of 4' pitch in reference to a 16' Principal. In this interpretation, Schlick's use of the term Double Octave would be identical with the modern understanding of the term. It is more likely, however, that Schlick's description "very large" refers not to an instrument with a great number of ranks,

but to an instrument with a lower pitch, e. g., an instrument based on a 16' Principal. In addition, the original passage plainly gives the Double Octave not as an optional addition, but as an alternative to the Octave rank in the case of a "very large" instrument. Thus the term "double" refers here to pipe length and indicates the relationship between the 4' Octave in a normal instrument of 8' pitch and the (double) Octave of 8' in a "very large" instrument of 16' pitch.

Jane Schatkin Hettrick

Bring the Broom South

I just received the January issue and read with open-mouthed wonder the letter from Ann Cunningham, who says that factories in the South are paying \$23,000 per annum for floorsweepers. Me, I'd love to move back down South, and if she'll tell me which factories are paying such wages, I'll be glad to take the job; indeed, I'll even bring my own broom.

Sincerely,

John S. Carroll
Emlenton, PA

Unauthorized Publication

We wish to alert the musicological community to the unauthorized publication by the Institute of Mediaeval Music, Binningen, Switzerland, of our manuscript *A Dictionary of Musical Morphology*. The publication is a corruption of our text and in no way representative of our work. Prospective buyers and reviewers are urged to wait for the printing of the proper text by a reputable American publisher.

Sincerely,

Siegmond Levarie
Ernst Levy
City University of New York
New York, NY

On Whisperchords

Bravo for publishing the exchange (Jones, Gustafson, Martin) about the problem of what Ralph Kirkpatrick so many years ago called "Whisperchords". How many more concerts will we have to go to where an obbligato harpsichord part is completely inaudible, or tinkles feebly in the background?

I have heard excellent musicians say that Bach must have written all those harpsichord concertos for the amusement of himself and his sons, knowing very well that they could not be played in public. Leonard Bernstein was recently quoted (New York Times): "Of course, one never hears the harpsichord." When harpsichordists try to make themselves heard against a string orchestra, the conductor will rap his desk and shout, "Less harpsichord; use only one choir."

For many years we did not know how to make harpsichords that could be heard. From this there grew up an idea that in an "authentic" performance, using harpsichord, the harpsichord ought not to be heard. So on a new recording by Von Karajan of the Brandenburgs with Tim Read at the keyboard of a very strong instrument, the harpsichord is taken down by the recording engineers, and that great cadenza in the Fifth sounds like it was being played from Mars. Albert Fuller's harpsichord in the new release of the Brandenburgs from Aston Magna can almost be heard — this is the best recorded version to date, and points in the right direction.

Philip Jones blames the instrument builders, but the relationship between builders and players is symbiotic, and the builder who wants to hear his instruments played in ensemble is frustrated by the players who want the keyboard to feel like an electric typewriter and are disconcerted, their technique completely destroyed by feeling the pluck.

Some points need to be made:

1. You cannot get more energy out of an instrument in the form of sound than you put in with the finger. It is now possible to build harpsichords of great efficiency in turning energy into sound, but the energy has to go into the system for sound to come out.

2. A small harpsichord will always sound larger (other things being equal) than a large one. This confuses many people, but the logic of it is simple: a large soundboard takes more energy to move than a small one. Of course,

self-respecting musicians will not think of appearing on stage with anything less than the largest harpsichord available, and it must be a double, even though there is never any reason to use two keyboards when playing any of the concerti or in any continuo. A keyboard with GG-d'' compasses all of Bach's writing for the harpsichord

3. The late French double ('copies' of which are the 'standard' harpsichord of today) was designed to play a certain kind of music in the small boiseries and salons which became popular among the aristocracy in the reign of Louis XV. To make Couperin flow and sparkle, yes, you need a very light action, and, for a small salon no very great sound.

But for Bach and Scarlatti you can hardly have enough sound.

And if the sound is too great for the harpsichordist practicing in his small room at home, let him put the lid down — or voice the instrument down and leave it at home when he plays in public.

4. Very many 'modern' harpsichords simply cannot be voiced up to audible levels (audible outside a living room, that is) without making a terribly harsh clutter. As long as the Whisperchord is in fashion, this disability is no great handicap to the builder.

5. Violins and cellos tend to eat up the soft, surrurous sound of the Whisperchord, so even if the harpsichordist thinks he is belting it out, twenty feet away nothing comes through the strings. A small fortepiano will balance a large orchestra, not with loudness but by the simplicity and clarity of its sound. If we continue to praise only the complicated, buzzy sound of the late French instrument, and of Flemish instruments rebuilt in France, we shall never get there. Some of the surviving German instruments, and Flemish instruments in their original form make the kind of sound that will cut through the strings (unless the voicer has tried to make them into fashionable Whisperchords).

6. It is time for instrument builders to stop crippling the players with strong fingers. The jackrail stop of the late French harpsichord is relatively fragile compared with the stop under the head of Italian instruments, or the touchrails of Flemish and German instruments. I read recently in a manual for regulation of harpsichords that "good players can play without the jackrail, never bottoming out on the key." Some people can eat spaghetti through their nose, too. If the player has to worry about his instrument, how can he worry about the music?

I have been perhaps more guilty than anybody else of trying to 'reform' the strong-fingered players. All of them take note: I am now myself reformed. I will even build crash rails if you need them.

Hurrah for Philip Jones, who wants to hear the harpsichord when it is played with other instruments (and in a large hall). Whisperchords are fine in a small study, but they have no place in concert halls.

Sincerely,

David J. Way
Zuckermann Harpsichords Inc.
Stonington, CT

**Article
Noted**

Ars Organi, journal of the G.d.O. (Gesellschaft der Orgelfreunde, Schaffhauser Strasse 22, D-7700 Singen, West Germany), includes in its Dec. 1980 issue an article by Hermann J. Busch on 18th- and 19th-century organs and organists in Berlin as they were viewed by Charles Burney and William Sparks. This publication, in German only, regularly contains a great deal of information on German organs.

Plan now to attend
The Southern Baptist
Theological Seminary
School of Church Music
CHURCH MUSIC INSTITUTE
October 19-22, 1981

Professor Gene Cho, Chairman, Theory Department, North Texas State University
Mr. James Corwell, Minister of Music, First Baptist Church, Somerset, Kentucky
Dr. Arnold Epley, Chairman, Music Department, Louisiana College, Pineville, Louisiana
Dr. Michael Hawn, Minister of Music, First Baptist Church, Decatur, Georgia
Ms. Linda Miller, Christian Artists Agency, Nashville, Tennessee
Ms. Linda Owens, Faculty, The Southern Baptist Theological Seminary
Dr. Steve Owens, Executive Vice-President of Truett Music, Truett Music, Nashville, Tennessee
Mr. James Richardson, Minister of Music, First Baptist Church, Savannah, Georgia
Dr. Robert Smith, Piano, Southwestern Baptist Theological Seminary, Ft. Worth, Texas
Mr. James Woodward, Chairman, Department of Music, Oklahoma Baptist University, Shawnee, Oklahoma

SPECIAL FEATURES:

- Address by new dean, School of Church Music, as part of an Inaugural Worship Service
- Installation of new dean, School of Church Music
- Class Reunions
- Class Reunions
- Opera Workshop Production

* For more information contact: Dr. Maurice Hinson, Church Music Institute Coordinator, The Southern Baptist Theological Seminary, 2825 Broadway, Louisville, KY 40203. Call out-of-state toll-free (800) 626-5525

ONLY AN ORGAN THIS ADVANCED COULD SOUND LIKE IT WAS MADE A CENTURY AGO.

Baldwin presents a classical organ that's, quite simply, decades ahead of time.

A classical organ designed to produce unsurpassed ensemble for service playing and congregational singing. With advanced microprocessor technology for longer life and reduced maintenance.

The Baldwin 635 SilentTouch™ Organ. A classic combination of art and science.

The science of sound. The magnificent sound of the Baldwin 635 originates in a multiple tone generator system. Featuring a total of four tone generators instead of the one or two found in comparably priced organs.

And, oh, what a sound it is. Rich. Full. Inspiring. With outstanding clarity and brilliance.

And you can make that sound do wonderful things.

Because the Baldwin 635 comes with a full complement of couplers for expanded tonal variety. Multi-channel amplification for greater acoustical flexibility. And the unique CathedraSonic pipe amplification system for a sound dispersion that rivals the tonal integrity of the pipe organ.

The technology of performance. The Baldwin 635 is engineered to provide maximum reliability.

Microprocessor technology replaces mechanical drawknobs and sets a new standard of dependability and instant response.

The exclusive SilentTouch feature assures registration changes with no noise. No hesitation. No delay.

And, because there are fewer mechanical parts to the 635, it requires far less maintenance and virtually eliminates component failure.

The art of leadership. The remarkable Baldwin 635 is available only through your Baldwin Master Organ Guild dealer.

These carefully selected and thoroughly trained dealers are fully qualified to help you select the classical organ that most completely meets your needs. Their knowledge, experience and service capabilities assure expert installation, reliable performance, and fast, dependable service.

All backed by Baldwin's 118-year reputation for leadership in keyboard excellence. Play the Baldwin 635 SilentTouch.

Hear art and science in perfect harmony.

Baldwin Piano & Organ Company
P.O. Box 2525 Dept. D-4
Cincinnati, Ohio 45201



Send me more information and the name of my Baldwin Master Organ Guild dealer.

I enclose \$3 for "Sounds of Faith" recording featuring Model 635.

NAME _____

ORGANIZATION _____

ADDRESS _____

CITY _____ STATE _____ ZIP _____

Baldwin®

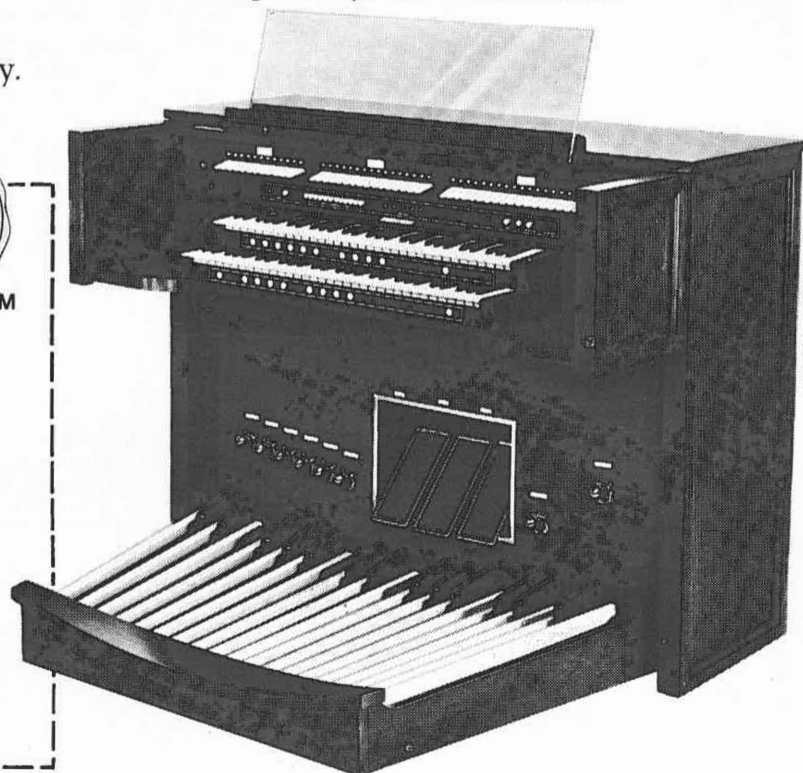

My Association with Ernest White

by the Rev. H. F. MacEwen

In the fall of 1936 I entered the Juilliard School of Music as a piano major, having come from the northerly regions of the Maritime Provinces of Canada. I had been in New York previously on a visit with my parents in 1934 and somehow or other in my walks round about the Times Square area stumbled upon the Church of St. Mary the Virgin, entered it and looked about, but hardly understood what it stood for or represented, save that I considered it to be "high". Then one Sunday in 1937 I attended a Palm Sunday service there when a mass by Victoria was sung. The elaborate ritual coupled with high-class singing impressed me deeply. The organist at the time was a Mr. Westerfield. Raymond Nold conducted the choir in the rear gallery, while the organist was unseen. The pipes were without a case, looking stark, jutting out in irregular arrangement above.

In the fall of 1937 a series of organ recitals was advertised by the new organist, Mr. White, containing a lot of Bach, pre-Bach, and more recent composers, some of whom I did not know. A friend from Toronto, a musical connoisseur, recommended these to me; he was an admirer of Willan and had attended his presentations at the Church of St. Mary Magdalene there. He declared that White followed in the same tradition. Now I had heard Willan highly extolled as a composer in Canada and as a teacher in Toronto of budding would-be composers, so I went to some of these recitals and heard playing that never before impressed me to such an extent. I had heard Germani and Dupré in New York give unusual performances, but these were on the usual organs, so that nothing exceptional in the way of difference in tone and acoustics was apparent. At St. Mary the Virgin, however, the effect of emphasis on harmonics in organ tone, coupled with the unusual acoustics of the building became altogether different. I was from that point a convinced admirer of the pipe organ and its literature.

The teachers and students at Juilliard then seemed to have no interest in good organ playing, much less in proper acoustics. They were for the most part either piano, violin, or voice majors, and were concerned about a career in their chosen line only. There was one fellow student and close friend who also started to go to hear the services at St. Mary's, and if I didn't go one Sunday she was there to report to me what music was given that particular day. At another time I heard one teacher mention the services there, but this was no pianist or violinist: she was an instructor in sight-singing. In fact, I can recall one distinguished pianist and later a teacher at that school express utter repugnance to the organ, claiming "the less she heard it, the better."

In 1939, I got the post-graduate diploma in piano, so determined after that to pursue some study in organ. I went to Mr. White, who agreed to take me as a pupil, and so began studies immediately with him in the fall. He had been playing the organ at the Temple of Religion at the World's Fair, giving recitals twice daily. Some of these were broadcast by radio and even heard over the Canadian Broadcasting Corporation. That instrument was built on baroque lines and sounded like an imitation of the St. Mary's organ over the air. It was at this temple that I heard a brilliant recital by Dupré, who was on his way back to France after a world tour, back to a land soon to be taken over by the Nazis.

At that time the organ at St. Mary's was as constructed in 1933 by Aeolian-Skinner, designed by G. Donald Harrison and Raymond Nold. Nold wanted an instrument designed along traditional French lines, but Harrison, realizing that in America the prevalent romantic design for organ specifications was responsible for the general public's lack of interest in organ music, was influenced to produce something in line with the older German organs of tone color and chorus ensembles. The result was that the instrument was French in the disposition of its forces, baroque in its use of mutations, and English in its reeds and diapasons. When White gave recitals on it the sound was utterly new to me, particularly in the mutations and mixtures, one that was grandiose and full as I had never heard before.

On this novel instrument were performed new selections from contemporary composers. Tournemire, Dallier, Langlais, Alain, Mulet, Maleingreau, and Messiaen were all new to me, as were the Germans Weigl and Schröder. The standard works of older composers received no neglect either; pre-Bach, Bach and some romantics were all heard to advantage. I recall how White had fabricated a cymbelstern, an arrangement of small bells tuned to the C-major chord and made to play this in broken arpeggio repeatedly. I sat beside a lady at a certain program when he played an old chorale prelude and used this light percussion. She immediately wrote on her printed copy, "bells". What would White's surprise be to learn that his instrument had a set of chimes within its confines!

At the beginning of my lessons he was all pleasantness and encouraged me continually. I began with Bach — the "Little Organ Book" and the larger preludes and fugues. He was particular about finger touch, using a kind of detached method, claiming that a bound legato was quite unsuited for good playing. My first instruction had been that an absolute legato was an essential for all organ playing, so this became a new departure, yet one that produced the best effects in the long run, although a certain allowance had to be made for the acoustics in any auditorium. St. Mary's was a large Gothic building where a certain echo was characteristic, and so, to avoid blurring, such a touch gave by far the best effects. He even claimed that touch could be used also to produce accentuation through the detachment of accompanying notes and holding slightly longer of main ones.

As for registration, he seemed to be in perfect agreement with his friend, H. William Hawke, whom he quoted in a series of lectures on the "Little Organ Book" and the Franck Chorals, given in New York around 1938. He

loaned me a printed copy of these which I had typed out and have with me to this day. The details I cannot discuss now, but he specified the registration for all the works. An excerpt from these lectures must suffice: he reminded us, "Bach was a prolific writer in the prelude form, but he was by no means the originator of any of the types of pieces that come under the general head of chorale-preludes. His predecessors had experimented with structure and materials, and much of their work is still available, but Bach, by the very power of his poetic and musical imagination took the material already at hand and built structures as had not been known before. He was the culmination of a period, and the times are reflected in him."

Not only did I study with him works of Bach, but we went on to Handel's concertos, Karg-Elert's chorale preludes, Franck's Chorals and the Reubke Sonata. He insisted that I must play his master Lynnwood Farnam's Toccata on "O Filii et Filiae," a number which he rendered with unusual brilliance himself. He loved to reminisce about Farnam, giving no end of anecdotes and particulars about this unusual man, how he practiced so diligently, how he added to his organ or modified it to get more depth and resonance, and how he performed so effectively in recitals at the Church of the Holy Communion on lower Sixth Avenue, where an elevated railroad rumbled by to "enhance" sound.

I terminated my lessons with Ernest White in early summer of 1940. He had that year acquired another of his studio organs which he placed in a large room upstairs at the church. This was a two-manual Aeolian-Skinner of precise voicing on which Carl Weinrich gave the opening recital. He used the cymbelstern on this occasion in one of the numbers, the only time I heard it used in addition to White's first introduction.

In early January 1941 I called him on the phone to tell him that I wished to return some music to him; what should be my surprise but to hear him say that he wanted to see me. Down I went to the church, to his room upstairs on the third floor, and was asked whether I would be interested to become an assistant to him in the services of the church. Of course, I acceded and soon found myself seated at the console accompanying the choir in whatever it used requiring accompaniment. Much plainsong and unaccompanied motets were the order of the day too, but pitch had to be given for these. Rehearsals were conducted twice weekly, on Wednesday nights and Saturday afternoons, two hours apiece. As a conductor White was particular, although I hardly think he knew much about voice production, and his manner was not ingratiating as it was at organ lessons. In fact, he would bawl the choir out at times. One nasty night I recall that he singled out certain singers as the actual dependable ones and the rest as mere hangers-on. One member assailed him at the end of the rehearsal, demanding some apology; how this ended, I don't remember. During Lent, he claimed that it was not ethical to use the organ at services, so plainsong prevailed then. But the clergy and members must have lodged some protest, demanding the organ prelude and postlude nevertheless. It was thus that I had some chance to play a bit for solos. Mr. White could always step in and supply in no end of pieces, but



Renowned for their exquisite sound...

I.T. VERDIN COMPANY
2021 Eastern Ave.
Cincinnati, Ohio 45202
(513) 221-8400

"Bell Ringers of America Since 1842"

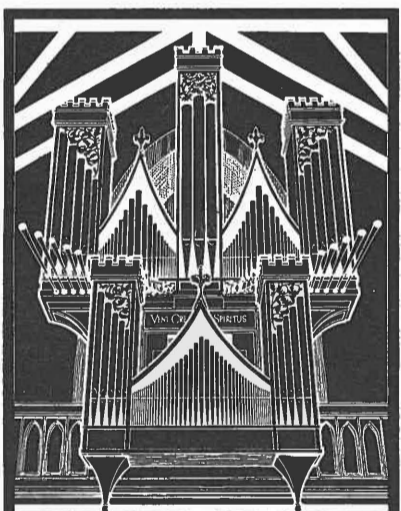

The Tracker Organ Revival in America

A bilingual reference-compendium compiled and edited by Prof. Dr. Uwe Pape. Among the contents: articles by John Fesperman, E. Power Biggs, Roy Redman, Josef von Glatter-Glitz, George Bozeman and Alan Laufman, Charles Fisk, and James Louder and Hellmuth Wolff.

Opus lists of 99 organbuilders
194 selected specifications, particularly of the large 2 to 4 manual instruments
272 selected photographs
488 pages in all
Make checks payable to Dr. Uwe Pape
\$48.00 postpaid; order from
Pape Verlag Berlin
8231 Ravero Street
Rockford, IL 61111

SCHOENSTEIN & Co.
EST. 1877
SAN FRANCISCO
3101 - 20th Street · 94110 · (415) 647-5132
Mechanical and Electric-Pneumatic Actions

<p>Organ Improvisation Workshop June 29 — July 3 July 6 — 10 (on demand) \$100 — 1 college credit</p>	<p>Lebanon Valley College</p>	<p>Church Choral Weekend June 26 — 28 \$50</p>
<p>For Information and/or Brochure Write or Call: Dr. Ann Henninger Lebanon Valley College Annville, PA 17003 (717) 867-4411 Ext. 213</p>		
<p>Registration Deadline: June 1</p>		

was gracious to let me fill in as a tyro.

I did not care too much for this work because I was not in sympathy with Anglo-Catholicism, being Presbyterian with a Reformed evangelical outlook, so our cooperation seemed to cool off. Well do I recall a drastic mistake I made at an evening vespers when I was supposed to give the pitch for an unaccompanied motet. Somehow or other I looked at the wrong printed copy and sounded the pitch of the next number. You never heard such a jumble that proceeded from the choir as the singers tried to gather the original pitches! I can hear White to this day impatiently exclaiming in undertones, "Pitch, please; pitch, please!" With heart palpitations I found the right number, gave the pitch, and the rendition proceeded. At the end I had to apologize, feeling like two cents. He was gracious indeed and forgot the incident. It wasn't long after that that he contrived the idea of making a small keyboard of three octaves to hook up electrically with the swell and positif organs, this to be operated directly under the conductor's desk, thus obviating any possibility of a wrong pitch being given from the organ console by the assistant, or if so, to let the responsibility rest wholly upon the conductor, who in this case would be too well versed in the numbers performed to do such a thing. He made this keyboard himself from materials taken from a console of an old chancel organ that was no longer used.

My services there were not much longer required when I devoted myself to the study of theology and prepared to become a minister. We parted on amicable terms, of course; sometimes I would run in to have a little chat with him. I found another position at the Reformed Episcopal church in New York where I remained four

years and in 1946 left to minister in Canada. I might add that White received another organ pupil from Juilliard who was shortly to become my wife. Her term with him was short but she too became founded in the virtues of the baroque organ and used whatever she could of stop selections to produce these effects in her organ playing. White did not care for the term "baroque"; he claimed that "we are not producing the American-classic organ. We are returning, as from a bad dream, to the organ." For his authority, he would quote from Dom Bédos de Celles who, he claimed, had "most minute details for the building of organs." "His recommendations are as applicable today as they were in 1766. Indeed, on the subject of building, little if any has been added, with the sole exception of mechanics — electric action and power blowing."

In 1943, he had the 1933 instrument reconstructed to bring it more in line with his personal persuasions. This became a truly grand organ. It must conform to the French organ built for a Gothic cathedral and for ritualistic services. He wrote, "We have gone to the past to find out what gave the best results over the longest period of time, but with no desire to produce a museum piece. St. Mary's organ is used as a recital as well as a service organ. This fact has produced several additions to the basic scheme. The extra set of strings on the Positif is a case in point, yet for this very addition there is a precedent. The French Positif is regarded as a contrasting full-Swell and is enclosed, as is the Swell. This division has no relation whatever to the German Positiv, which is regarded as an unenclosed foil to the Great. So if the Swell is allowed two sets of strings, the contrast division certainly should be allowed the same material, provided there is a difference in both scaling and voicing."

White did not like the open diapason tone and would not use it on any organ on which he gave a program. About St. Mary's organ he declared, "My personal dislike for diapasons does show in the specification. Diapasons as we know them are a fairly recent development. The older examples were quite light and hybrid in tone. This 'old' diapason tone may be produced by the union of any well-voiced string with a stopped flute of the same pitch. Instead of tying these two sounds together on one knob and labeling it Diapason, I prefer the extra color possible from using the two elements." For the four-foot pitch he would recommend the Flute Courte and the Salicet together, to "produce an interesting principal color. So when you are able to provide both color and power by other means, the separate stop seems unnecessary."

I called one day and had him demonstrate this new instrument to me, with all his explanations of the various sounds and how the pipes were constructed, much of which I could not clearly understand. I remarked to him, "An ordinary organist can hardly cope with this," to which he replied curtly, "This is not for any ordinary organist." At another visit in 1949, the last I had with him, he was complaining of bad health and his days seemed to be numbered, but he outlived them to thirty-one years beyond. He still emphasized his appreciation of the instrument there and the grandeur of its sound.

He sent me a copy of a recital program he presented at Riverside Church in New York City, and this was his final one in a city he termed a "hick town" in reference to its general lack of appreciation for the best in organ music. I can hardly agree with him in this, for there were always generous attendances at his recitals at St. Mary the Virgin. Associates of Ernest White still remember him.

Honors



Laraine Olson Waters has been awarded a three-year performance sponsorship by the Pro Musicis Foundation, which promotes concert careers for young artists. A graduate of Syracuse University and Wichita State University, she is the first organist to be recognized by the organization. She has studied organ with Donald S. Sutherland, Robert Town, and Marie-Claire Alain.

H. C. Robbins Landon has been named musicological advisor for the Classical Music Seminar to be held Aug. 4-18 in Eisenstadt, Austria, under the sponsorship of the University of Iowa. Mr. Landon is currently on the faculty of the University of Cardiff, South Wales, and is a noted Haydn scholar.

PIERRE D'ARCHAMBEAU, violin

MARILYN MASON, harpsichord

Duo Recitals

Pierre d'Archambeau is at the present time one of the "high Priests" of the violin. . . .

Pierre d'Archambeau's name appears frequently in concerts in New York and elsewhere. He is always received with great esteem. Currently he is presenting in two recitals the integral performance of the six Bach and the six Handel sonatas for violin and harpsichord with the distinguished artist Marilyn Mason. . . .

The first of the two concerts was Friday in Carnegie Recital Hall. The second one will take place a week later, Friday December 12.

These twelve sonatas are monuments of polyphonic scripture from the baroque period.

We listened with great interest to the first of the two concerts, including three Bach and three Handel sonatas, and we were struck by the serious concern of the two artists about the style and the message of this music.

Mr. d'Archambeau shows a beautiful tone, an impeccable intonation, as well as a supple and vigorous bowing. His phrases are intelligent and show a deep study of the works.

Mme. Mason shows the very same qualities. Let us add that the two partners show a masterly control of their instruments.

—Edgard FEDER
(France-Amerique)

Murtagh-McFarlane Artists, Inc.

127 Fairmount Avenue

Hackensack, New Jersey 07601

201-342-7507



Renaissance in Organbuilding in Northwest Ohio

by James J. Hammann

Northwest Ohio is an area of beautiful level farmland, many small industrial and farming communities, and the large city of Toledo. It is not the place that one would expect to find many important new mechanical-action organs, but over the past ten years a gentle revolution has taken place, and not only are there several widely acclaimed new mechanical-action instruments, but Toledo also has its own tracker organbuilder.

Toledo Organbuilder

Daniel F. Pilzecker has to be classified with that new breed of organbuilder that not only knows the organ as a craftsman, but also as a musician. While he was still in high school, he was not only working for one of the local organ repairmen, but was also taking organ lessons from Harold Harter, the first dean of Toledo's A.G.O. chapter. Mr. Pilzecker then enrolled at the College Conservatory of Music of Cincinnati, where he studied organ with Parvin Titus, and later studied both organ and liturgy privately with Marcellus Becker. Following military service, he apprenticed himself with Hillgreen-Lane, and also did installation work for Aeolian-Skinner. Later Mr. Pilzecker also worked with Robert Noehren. A trip to Europe to study historic instruments capped this theoretical and practical education.

Mr. Pilzecker's first sizeable venture into mechanical action was the restoration of the 1872 Derrick & Felgemaker organ in the Unitarian Universalist Church in Norwalk, Ohio. This was followed by the restoration of an 1885 Johnson in St. Mark's Episcopal Church in Coldwater, Michigan. Reconstructions include the re-trackerization of an 1872 Garret House instrument which had been electrified and "modernized" in the 1940s and the reconstruction of the historic 1893 Johnson at Grace Episcopal in Sandusky, Ohio. Special mention needs to be made of the Sandusky Johnson, because it was this instrument that Herman Schlicker tonally rebuilt under the direction of Robert Noehren in the 1950s, and upon which Noehren made so many landmark recordings. The Pilzecker reconstruction of this historic instrument was also carried out in consultation with Dr. Noehren.

The largest entirely new tracker organ by the Pilzecker Company is the three-manual and pedal, 65-rank instrument for Gesu Jesuit Catholic Church in Toledo. This organ is the end result of a good deal of scholarship dealing with European and En-

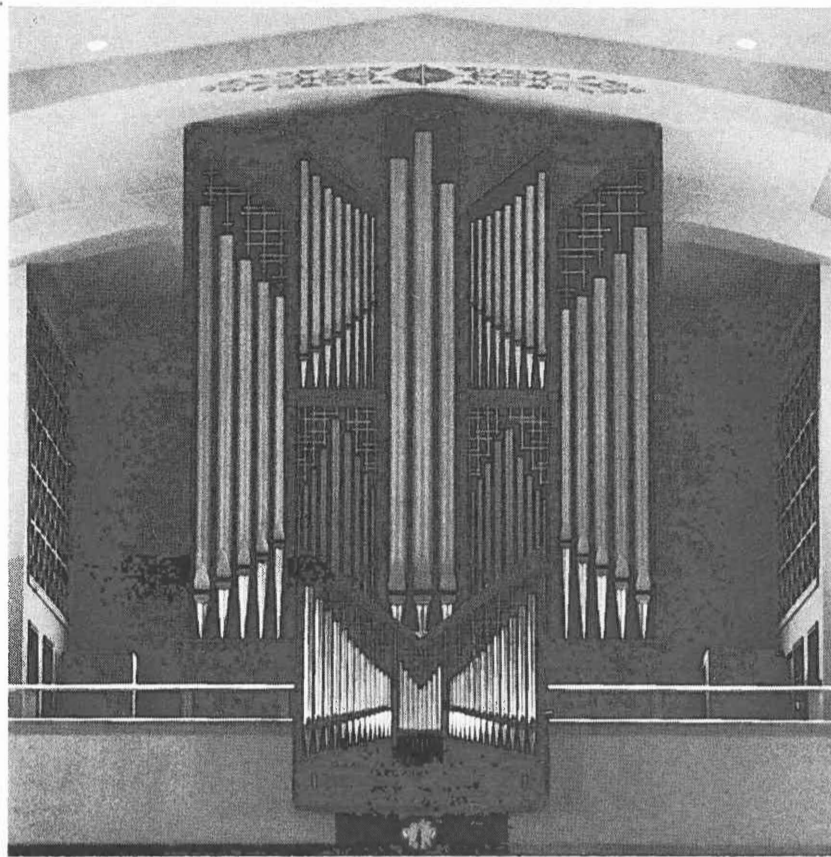

Pilzecker organ (III-65, 1973) at Gesu Catholic Church, Toledo.

glish instruments, with a special emphasis on the scalings of these instruments. It is essentially an eclectic instrument of two main manual divisions (Hauptwerk and Rückpositiv), with a primary emphasis on the relationship of contrasting principal choruses. The Swell organ should be considered supplementary to these other two manual divisions. The Swell represents both the French and English traditions with the chorus reeds being patterned after Cavalié-Coll and the Hautbois and Vox Humana after English models. The Swell principal chorus is really a small English Great division. The Pedal organ relates to all manual divisions, has its own complete principal chorus, and has two reed divisions representing the French and German methods of construction and voicing. The instrument is located in the rear gallery of a large nave with hard surfaces and over five seconds reverberation. This project took over three years to complete and was dedicated in 1973 by Robert Noehren.

The present project in the Pilzecker shop, which is located on the second floor of a large pre-civil war building at one time the local brewery, is the restoration of an English chamber organ, circa 1750, thought to have been made by either Richard Bridge or George Pike England.

Bowling Green State University

The renaissance in organbuilding is easily traced at Bowling Green State University. Located twenty miles south of Toledo, and founded in 1910 as a teacher-training institution, it became a university in 1935, and acquired its first pipe organ, a four-manual Kilgen of 44 ranks, in 1937. Palmer Christian dedicated this instrument, which was sold to a church in Alabama in 1973.

By 1957, the music school had grown large enough to be moved into a new building and in the recital hall a three-manual, 29-rank Schantz was installed that had been designed by Walter Holtkamp Sr. This organ, of course was constructed along the lines of classic organbuilding, but still had electro-pneumatic action and no case.

By the middle 1970s the School of Music again required larger quarters and so in 1979 the new Musical Arts Center, designed by Toledo architects Bauer, Stark, and Lashbrook, was opened. In addition to over sixty studios and offices, two performance halls, two rehearsal halls, and practice rooms, there are four mechanical-action organs. The Schantz from the old recital hall was also moved into one of the new performance halls.

The main teaching and recital instrument is a 20-rank, two manual and pedal instrument by Rudolph von Beckerath. It is installed in an organ studio with a 20' ceiling, that boasts excellent acoustics, has a stained glass window, seats 60 people, and even contains a small balcony. A 15-rank, two-manual tracker organ by Kurt Ruhland was purchased from the local Methodist Church, refurbished, and installed on a moveable platform in Kobacker Concert Hall so that it could be pushed on and off stage. A 7-stop mechanical-action practice organ by Casavant, and a 3-stop practice instrument by von Beckerath are also located in practice rooms. Vernon Wolcott is the university organist and will be heard in recital on the large von Beckerath during the Toledo A.G.O. Regional Convention this June.

Instruments by John Brombaugh

Toledo also has two mechanical-action organs by John Brombaugh. Both instruments are patterned after Flemish organbuilding of the 17th century, and both instruments have unequal temperament after Andreas Werckmeister. The first of these instruments which was installed and dedicated in 1971, is the 14-rank, two-manual organ in Plymouth Congregational Church. Because of its unique construction, utilizing a single windchest with pallets on each end of it, it has a 2' Principal which can be played from either manual, although not both at the same time. The 8' Praestant and the 8' Trumpet in the Great also play in the Pedal. The organ is located in the rear gallery and has a white colonial case to match the church woodwork and furniture.

The second Brombaugh organ, installed in 1972, is located in Ashland Avenue Baptist Church. It is a two-manual instrument of 19 stops and is installed in a gallery over the baptistry in the front of the church. It has an elegant case of shellacked red oak which is decorated with gold leaf and embossed praestant pipes. A single hinged bellows supplies the wind. The wind is flexible, and the pressure is around 90 mm. The key action is of the suspended type. The stop controls for the Rückpositiv are located to the rear of the organist in the case, and caused one nationally-known organist to remark "how convenient" when a student reached and missed the sought after stop. Organists from throughout the world have come to Toledo to see and play this instrument, and the Pilzecker organ at Jesu. Both of these organs will be featured at the 1981 Toledo A.G.O. Regional Convention.

James J. Hammann, M.M., AAGO., is director of music at Central United Methodist Church in Detroit, Michigan.

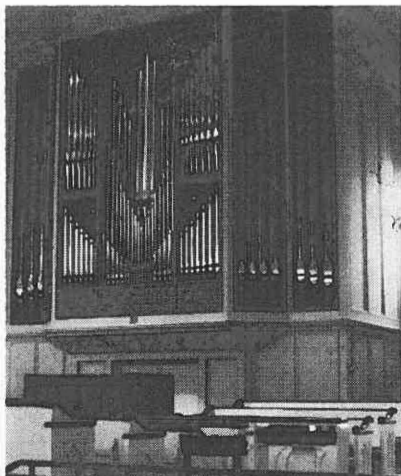

Pilzecker reconstruction of 1893 Johnson at Grace Episcopal Church, Sandusky.



Casavant practice organ (II-7) at Bowling Green State University.



Beckerath organ (II-20, 1979) at Musical Arts Center, Bowling Green State University.

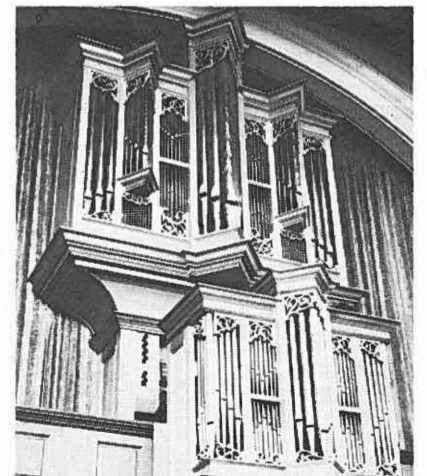

Brombaugh organ (II-21, 1972) at Ashland Avenue Baptist Church, Toledo.

An **International Organ Festival** will be held July 4-11 at St. Albans in England. Performances will be given by the Academy of Ancient Music; the choirs of Guildford Cathedral, St. George's Chapel, Windsor, and St. Albans Abbey; and organists Peter Hurford, Gillian Weir, and Piet Kee. There will be a competition, and works by Rory Boyle and Anthony Milner will be premiered. Further details are available from the International Organ Festival Society, P.O. Box 80, St. Albans, Herts AL3 4HR, England.

The **7th Academy of Italian Organ Music** will take place Aug. 23-Sept. 2 in Pistoia, Italy. An organ course will be taught by Luigi Ferdinando Tagliavini, Colin Tilney will give a harpsichord course, and Franco Baruccchieri will teach harpsichord tuning and maintenance. Umberto Pineschi will offer an introduction to the Pistoian organ, and there will be additional seminars and concerts. Registration is requested by May 10. Further information is available from the Secretary's Office of the Accademia di Musica Italiana per Organo, Via Della Madonna 28, 51100 Pistoia, Italy.

A **Festival of British Organ Music** will take place at the London church of St. Michael, Cornhill, during May, June, and July, when three of England's leading music publishers will sponsor recitals. Recitals will be given by Roger Fisher (Chester Cathedral), Simon Lindley (Leeds city organist), and John Birch (late of Chichester Cathedral), playing compositions published by Novello, Oxford University Press, and Basil Ramsey. The works will range from 17th-century pieces to the UK premiere of Kenneth Leighton's "Missa de Gloria." The organ in St. Michael's, Cornhill, dates in part from a Renatus Harris instrument of 1684 and was last rebuilt in 1975.

Summer Events

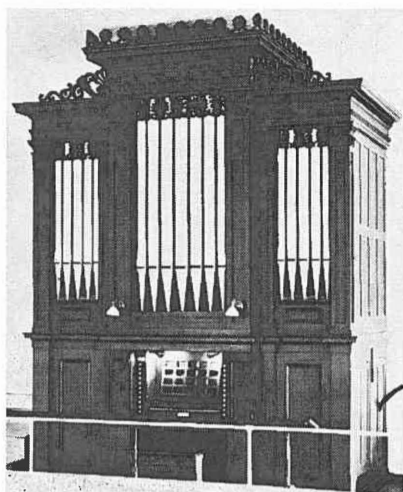
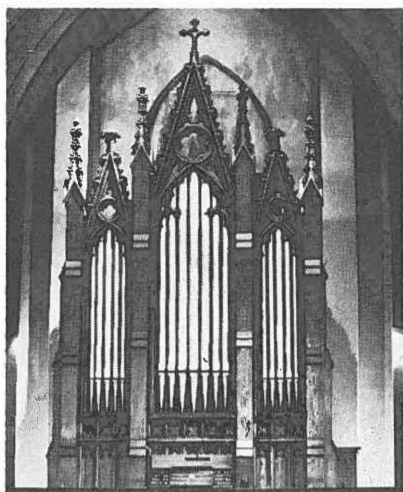

Among organs featured at the OHS convention will be (left) the E. & G. G. Hook Op. 288 of 1860, at St. John's Catholic Church in Bangor; and (right) the 1848 George Stevens at the First Church in Belfast. Both instruments have been restored by Bozeman-Gibson & Co.

Organ Historical Society to meet in Maine

The **Organ Historical Society** will hold its 26th annual national convention in northeastern Maine from June 22 to 25. The convention will have its headquarters at the University of Maine's Orono campus, near Bangor. Demonstrations and recitals will be played by Marion Anderson, Sue Armstrong, William Ayesworth, David Bergeron, George Bozeman Jr., Nina Hollifield, Earl Miller, Rosalind Mohnsen, Barbara Owen, Charles Page, Lois Regestein, and Elizabeth Sollenberger. Among the organs featured will be ones by Henry Erben, E. & G. G. Hook, Hook & Hastings,

E. L. Holbrook, Emmons Howard, George H. Hutchings, and E. W. Lane. Of special interest is the concentration of instruments by George Stevens remaining in the area, of which three will be heard at this convention. A catered dinner and major recital by Karel Paukert will conclude the official events, although an additional day will be offered for those wishing to stay and explore churches to the south of the area.

Further information and registration details are available from Charles Ferguson, Registrar, Box 44, East Vassalboro, ME 04935.

The **27th International Summer Organ Academy** will take place June 28-July 12 in Haarlem, Holland. The faculty will consist of Ton Koopman (Sweelinck and the North German school), Ewald Kooiman (J. S. Bach), Hans Haselböck (improvisation), and Alan Curtis (harpsichord). Because of restoration work being done at St. Bavo Church, the famous Müller organ cannot be used; the activities of the academy will take place on various historic organs in the area. During the first week, the International Improvisation Contest will take place on the newly-restored Moreau organ (1736) in Gouda, where judges Peter Planavsky, Bernard Bartelink, and André Fleury will also play a concert. Applicants for the academy must apply by May 30. Further information is available from Stichting Internationaal Orgelconcours, Townhall, 2011 RC Haarlem, The Netherlands.

The annual **Box Hill Festival** will be held this year at Cleveland Lodge, home of Susi Jeans, the festival director. Noted for its championship of neglected and rediscovered scores, the festival will mark the 200th anniversary of the death of Sir William Herschel, the astronomer who discovered Uranus. Herschel was also an organist and composer of music for the organ; his music has long been a pet project of Lady Jeans. The dates of the festival are June 5-7, and June 14. All concerts will be held in the music room of Cleveland Lodge except that on June 14, which will be in the parish church at Mickleham.

The June 14 concert will introduce the Sine Nomine Singers of London, conducted by Laurence Jenkins. The music of William Savage and his students R.J.S. Stevens and Thomas Battishill will be the focal point, and Lady Jeans will also perform. Further information is available from the Secretary, Cleveland Lodge, Dorking, Surrey, England.

OUTSTANDING PERFORMERS FOR OUTSTANDING INSTRUMENTS

MARK BROMBAUGH organ, harpsichord, pedal harpsichord
Faculty, Westminster Choir College

LYNN EDWARDS organ, clavichord
The Westfield Center for Early Keyboard Studies

YUKO HAYASHI organ
Chairman of the Organ Department
New England Conservatory of Music

MARGARET IRWIN-BRANDON organ, harpsichord, fortepiano
College Organist, Mount Holyoke College

PAUL O'DETTE lute
Director of Early Music,
Eastman School of Music

EDWARD PARMENTIER harpsichord, organ
Faculty, University of Michigan

EDWARD PEPE organ
The Westfield Center for
Early Keyboard Studies

WILLIAM PORTER organ, harpsichord
Faculty, Oberlin College
Conservatory of Music

CHRISTA RAKICH organ
Faculty, New England Conservatory of Music
Assistant University Organist
Harvard University

HARALD VOGEL organ
harpsichord, clavichord
Director of the North German Organ Academy

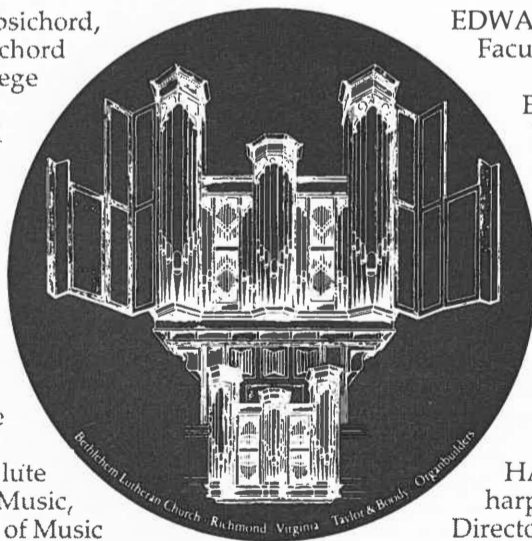

MICHAEL LYNN and EDWARD PARMENTIER recorders and Baroque flute with harpsichord
MUSICALISCHE COMPAGNEY late 16th- and 17th- century brass and wind ensemble
THE MUSICIANS OF SWANNE ALLEY music of Michelangelo's Italy and Shakespeare's England
MUSICK FOR THE GENERALL PEACE Baroque chamber music

Buchanan Artists Ltd.

Chester, Massachusetts 01011

Inquiries invited.

Telephone: (413) 354-7701

Some Thoughts on the Sound of the Organ

by John David Peterson

Great works of music always reveal fresh facets of themselves every time we approach them. They seem to keep their treasures in reserve, giving us only one or two at a time and holding on to others in order to delight us another time. Even an unpretentious work like J. S. Bach's "*Ich ruf zu dir*" from *The Little Organ Book* can disclose new riches. Recently it helped me crystallize some half-formed thoughts about the sound of the organ.

There was no flash of light as I practiced, no startling dramatic revelation. The outer voices seemed as I have understood them before — the bass pizzicato, like the bass of "*Erbarme dich*" from the *Passion according to St. Matthew*, the soprano on a gentle reed or a nasard combination, with tremulant. The new discovery, emerging during my search for an appropriate sound for the middle voice, centered on a very basic question: what guidelines are there for the choice of tone-colors on the organ?

Sometimes it seems impossible to approach that question with any sense of security. We would like to make a piece sound the way it sounded to its composer, but organs have changed so much, and any organ, old or new, badly or well-preserved or restored, offers us an array of choices of sounds the like of which is not given to any other instrumentalist. We are often satisfied with stop-lists, but these provide only raw information and can actually be misleading. Even lists of registrations from organists of the past are problematic, divorced as they are (for us) from their respective instruments and from a sense of the taste of the time.

We would like to have aural documentation, not just of the sounds available, but of the ways in which composers used those sounds. We would like a sound source not subject to vastly differing choices, one unaltered from a previous century to this one, one which would show us which of many historically possible sounds would have been musically feasible. And as I flipped stop-knobs trying to find the best timbre for the middle voice of "*Ich ruf zu dir*", a thought which had been vague before formed itself clearly: we do have such evidence. It is instrumental music, both chamber and orchestral.

With this statement I do not intend even to consider arguments about the organ's capability to imitate other instruments. I merely mean that the sound of 18th- and 19-century orchestral and chamber music played today is not so very different from its sound when it was first played. This is not to say that there is no difference in timbre between an 18th and a 20th-century oboe or no difference in the sound of a section of violins (Baroque or modern) playing with or without constant vibrato. But the basic orchestral timbre is prescribed and differences in sound from one era to another are limited, whereas the differences in organ sound are legion because of the many choices of stops. I fear that we have often made organ music, especially that of the German Romantics and J. S. Bach, sound vastly different from the rest of the music of those composers. Through careful study of chamber and orchestral music, we can discover correspondences with the organ works and get a feel for musical color, for the character of solo sounds. We can also gain a better understanding of the creative source of which a composer's organ works are one expression.

Let us look for a moment at Brahms, whose orchestrations call for a rich blend of dark colors. His favored instruments were horn, viola, violoncello, and clarinet, and his piano works challenge the player to call forth half-and counter-melodies from the tenor register of thick textures. It is not surprising that his organ works share the same sense of musical color. "*Herzliebster Jesu*" and "*Herzlich tut mich erfreuen*" contain dynamic marks but no directions for change of manual. Brahms' intention seems to be one timbre at different dynamic levels, and that can be accomplished either by using the swell-pedal or by using two manuals of similar quality coupled together. The intertwining of the voices in the second setting of "*O Welt, ich muss dich lassen*" implies that the echoes should not have dramatic changes of tone quality. It can also imply the coupling together of all three manuals, a usage consistent with the sound of the orchestral works and with the design of German organs of the time.

More problematic are "*Es ist ein' Ros'*" and "*Schmücke dich*". "*Es ist ein' Ros'*" figures in my thoughts here because its form is so much like that of the main theme in the second movement of Brahms' third symphony. The registration for this prelude which has pleased me most reflects this similarity. I try to imitate the effect of woodwinds for the first statement in each section — usually with bright flutes 8' and 4' — and that of strings in the second statements with two or three 8' stops. I will even admit to soloing out the tenor melody — I have not yet found the organ that projects that buried tenor voice — but on a mild 8' principal and with the manual coupled to the pedal, so the difference between the melody and the other voices is more of volume than of tone quality.

"*Schmücke dich*" has often been played on a sound reminiscent of a music-box: flutes 8', 4' and 1-1/3'; or flutes 8' and 2' (or one hand on each), with the melody on a 4' Schalmey in the pedal. Such a sound has no parallel in any of the music of Brahms. We should look to the *Two Songs for Contralto with Viola Obbligato*, Op. 91, for a guide to idiomatic tonal contrast. The alto, the darkest woman's voice, and the viola, the alto of the string family, engage with each other in gentle interplay against the piano's somber support. The soloists' timbres are distinctive and yet not so very different from one another, and the listener remembers the exquisite blend. Following this guide, for "*Schmücke dich*" we can draw a few 8' stops, perhaps including a mild principal, and play on one manual, as written. This allows the characteristics that stops have in different ranges to make subtle contrasts among the three voices.

Similar effects can be found in the music of Felix Mendelssohn. The obbligato instrument at the beginning of the great baritone aria "It is enough", from *Elijah*, is the violoncello, which vies with the singer in the same way that the viola does in the Brahms songs. The solo instrument is not an English horn, an obvious choice for strong contrast, nor an antique zinke rescued from a museum shelf. It is a solo string played against a background of strings in company with the human voice of similar range and character. Contrast is achieved subtly, by volume and by the difference between solo and section sound.

This can tell us something about the degree of contrast desirable in the adagio of the first organ sonata, in which one manual serves first as "section" and then as solo. It can also tell us about the cantilena of the second sonata, which appears in both soprano and tenor registers before it divides into two parts.

Mendelssohn's recommendations for registration in the preface to his sonatas are general suggestions according to volume level.¹ For very soft passages he calls for sounds of 8' pitch only. His preference for darker sounds should keep us from drawing the 8' and 1' in some of the baroque-looking (but romantic-sounding) variations of *Sonata VI*, or full French Swell, box closed, in others. If the musical effect of our performances reminds us of the "Scotch" or "Italian" symphonies, we are on the right track.

Robert Schumann's organ works, too, demand richer rather than brighter sound. The busy rustling of staccato strings in the scherzo of his *Symphony II* can best be approximated in the fifth organ fugue by flutes and strings (or light principals) 8' and 4'. One of our difficulties with this sort of sound, especially on smaller instruments, is with principals which may be too heavy, may speak sluggishly, may bark, or may dominate the ensemble. This is limiting, because it is a well-voiced principal which can best match the intensity and flexibility of a bowed stringed instrument. The organist whose 8' Great Principal speaks promptly and evenly down to low C and sings without sounding forced is lucky indeed.

What guidelines are there for the choice of tone-colors on the organ? Study of instrumental music is instructive not only for music of the 19th century. The dilemma of playing the music of Arnoldt Schlick on a modern instrument can be eased by modelling one's playing after that of a Renaissance consort. (That Renaissance musicians thought in these terms is attested by the number of stops, especially reeds, named for the instruments which they imitate.) Sounds of Renaissance instruments were thinner, more characteristic; none of them was extremely loud; contrast among voices could be stark. By following these guidelines, it is possible to produce a musical result even with apparently problematic works.

The fantasies of Mozart, which have been played with timbres varying from flutes 8' and 2' throughout to full organ with violent romantic reeds, acquire musical consistency when performed on a sound with the clear vibrancy of the orchestral sound of the last symphonies, *Die Zauberflöte*, and *La Clemenza di Tito*. This can be accomplished in the fortes with a principal chorus probably without reeds, which could muddy the sound, and without high mixtures, which could become strident. Hans Haselböck has suggested a similarly strong sound — with 16' pedal and without mixtures altogether — a confirmation of these stylistic comparisons by his research on the instruments that Mozart knew.²

In approaching the organ music of J. S. Bach, we should look at the style of organbuilding of his native region, represented by the organs of churches which he served.³ These organs reflect a regional tradition in which string stops were common, even on small organs; in which coupling (and therefore blend) was an important element;⁴ in

which mixtures were smaller than their North German counterparts; in which short-length reeds were not numerous.⁵ Viewed against this background, Gottfried Silbermann's work, foreshadowing subsequent developments though it did, seems to have more about it of organic development of an existing style than of innovation.

A good starting-point for comparison of Bach's organ works to other instrumental works are those pieces which are transcriptions — the "Schübler" chorales and two of the sonata movements — and those which are obvious adaptations of chamber style — the trio sonatas in their entirety and some of the chorale preludes.

The "Schübler" chorales are particularly instructive. The upper voice in the original of "*Wachet auf*" (Cantata 140) is played by all the violins and violas in unison. It is very likely that Bach's "8'" marking in the organ version means precisely that: only stops of 8' pitch.⁶ Two or three 8' stops, presumably including a principal, do produce a sound very much like that of a half-dozen strings played in unison. In any event, a bright sound would make the transcription inaccurate — only two notes in the entire obbligato are high enough to be played on the "e" string of the violin. The prescribed sound is rich, not thin.

Rich sounds also appear in the *cantus firmi* of Bach's orchestral scores. The chorale melody in the duet "*Erdenket die Barmherzigkeit*" from Cantata 10 (the "Schübler" chorale "*Meine Seele erhebt den Herren*") is given to two oboes and a trumpet in unison — a far cry from the lonely short-length reed to which the organ version is often entrusted.

The two treble voices of "*Wer nur den lieben Gott läßt walten*" are the soprano and alto voices in the duet "*Erkennt die rechten Freudenstunden*" from Cantata 93. Of course we need to emulate the smoothness of fine singing, and we need to study the score of the original version to determine the ends of phrases according to the words. But my principal concern here is sound. What organ stops produce the same feeling as human voices? At the moment my preference is for flutes 8' and 4', especially if the 4' flute has some character. Our ideal should be a vibrant, literally cantabile sound. A tinkly sound or a shrill one will neither match the vocal ideal nor caress the listeners' ears in legato playing.

For "*Ach, bleib' bei uns*" we again find ourselves either very happy with our fine 8' principal or, more likely, wishing for one again — for what stop, either by itself or with the 4' Octave, better emulates the intensity of the violoncello piccolo? Another registration which can work is the 4' Octave with a different 8' stop or two (a spitzflute or a gemshorn or both together imitate the attack of a bow on a string better than a gedeckt.) The refined atmosphere of chamber music pervading this elegant little work depends greatly on the timbre of the *cantus firmus*. The boys' voices of the original are better transcribed by a gentle, even throaty reed, than by a buzzy, intense one.

The instrumental versions of the two transcribed sonata movements require distinctive colors. The first movement of *Sonata IV* (a *sinfonia* in Cantata 76) was written for viola da gamba and oboe d'amore — both instruments with dark timbres. The top parts of the *Adagio e dolce* in *Sonata III* (the slow movement of the "Triple Concerto" in A Minor) are given to harp-

sichord, first with flute, and then with violin. We must remember that these sonatas are unabashed adaptations of instrumental forms and styles, so comparisons to instrumental timbres are inevitable. Some movements — notably the slow movements of the first and fourth sonatas — invite manual registrations of minimum contrast: two flutes, perhaps, or two principals spinning interlocking lines of exquisite elegance. Other movements suggest the degree of contrast of gamba and oboe d'amore. Once again, tinkly, insubstantial registrations do not reflect instrumental timbres, and they can actually obscure the give-and-take which delights us so much in these trios. What is important for the fast movements is agility and promptness of speech. On an undistinguished organ, the use of bright sounds may be the only means for achieving those aims; on a fine instrument, more idiomatic solutions are available.

It is interesting to note that in a sonata written for chamber trio, all movements are performed on the same instrument. While to make a rule of that for the organ trios would deny the wonderful advantage of the organ's varied colors, it may lead us to think of the possibility of more consistent tone-colors among movements of some of the sonatas.

I do not think that I merely have a fetish for dark sounds, though I disliked ephemeral sounds in the solid, 'cello-like lines of "Ach, bleib' bei uns" and the two-voiced prelude on "Allein Gott in der Höhn' sei Ehr'" long before I made the comparison to instruments. Nor do I think that I am merely "grinding an axe" for the rare 8' principal which can function as a solo stop. These thoughts are not a systematic catalog either of organ stops or of orchestral sounds and do not touch on a number of topics. I have not mentioned, for instance, the dou-

ble-reeds of the baroque orchestra, which are much more like cromorne stops or combinations of mutations than like the *Schnarrwerk* of earlier Dutch organs.⁷ (Obviously this has meaning for registering Bach's music and is reflected in 18th-century Saxon organ design.) I have not touched on music of this century, although Jean-Jules Roger-Ducasse's impressionistic *Pastorale* and Frank Martin's two orchestral versions of his organ *Passacaille* offer more than ample material. Nor is my point here that baroque performers drew bright "gap" combinations far less frequently than modern performers (though Peter Williams is also of that opinion).⁸ I am speaking for an understanding of organ music as *music* first, born of the same impulse as other music and bound by the same sense of style, a sense of style which includes timbre. Byron Belt's observation that "... organists continue to play essentially for other organists" strikes uncomfortably close, as does his plea for playing "... that reaches out, that embraces the listener with the sheer vitality and the love of music — not just the organ itself."⁹

All the study in the world will do us no good if we satisfy ourselves with historic availability. It is the deeper question of musical appropriateness that should concern us. Musical works, like oil canvasses, are of different dimensions; waves of sound may gently tease us or may completely engulf us. Lines may contrast like those of Octavian and the Marschallin or may blend like those of Susanna and the Countess. Without knowing our music from the ground up, we may distort its proportions, its timbre, its very sense. So, while orchestral and chamber music may offer us a barometer for the sake of comparison, our primary foundation in recreating musical masterpieces must still emerge from

our understanding of the music itself. From that base our musical imaginations must be ready to be inspired and to bend with new insights and new experiences.

It is a commonplace that to use a krummhorn stop in the *Andante sostenuto* of Widor's *Symphonie gothique* would be (at the very least) an historical inaccuracy. It should also be considered that the use of a krummhorn in a given 17th-century German work may constitute a musical travesty, no matter the fact that such a stop existed on many German organs. By allowing the music to unfold itself to us, by viewing it in its context we can approach it truthfully. Then our performances will highlight the music that we know so well instead of calling attention to the instrument.

But I have strayed far from "Ich ruf' zu dir." Its middle line has always looked to me like a string part, a viola obbligato in a movement from a passion or a cantata. With that ideal in mind, I tried a string-like sound and found myself much happier with the piece than I ever had been. The appropriate stop might be an 8' principal, or an 8' gemshorn (with or without an 8' spitzflute), or even a 4' principal played an octave lower. Such a sound is a wonderful foil to the gentle reed or the nasard combination of the cantus firmus, and the tremulant can be drawn for both manual voices. Legato playing enlivened by slurs (following those of the autograph) brings this musical line even closer to the ideal of string-playing and displays even more clearly the strong affinity this prelude has with the passions, though it predates those works by about ten years. And now I look at this unpretentious little piece with deepened affection — and curiosity for what else it will teach me in days to come.

NOTES

¹Reprinted from the collected edition in Felix Mendelssohn, *The Complete Organ Works* (New York: Lea Pocket Scores No. 48, 1954), p. 2 (24); translated in n. 23 of Douglas L. Butler, "The Organ Works of Mendelssohn," Part IV, *The Diapason*, 70 (Nov., 1979), p. 19.

²Hans Haselböck, "New Information About Mozart's Clockwork Pieces," *The Diapason*, 68 (Nov., 1977), pp. 12-13.

³Specifications of the organs of Bach's church positions show Saxon characteristics clearly. Harold Gleason, *Method of Organ Playing* (6th ed.; Englewood Cliffs: Prentice-Hall, Inc., 1979), pp. 277-279.

⁴In 1708 Bach requested a *Viol di Gamba 8'* on the Great of the Mühlhausen organ, to "... concord admirably with the 4-foot *Salicional* already included in the Rückpositiv." Hans T. David and Arthur Mendel, eds., *The Bach Reader* (rev. ed.; New York: W. W. Norton & Company, Inc., 1966), p. 59.

⁵Ernst Flade gives a specification for the organ built for the Frauenkirche in Dresden in 1621 which had only one reed for three divisions and in general looks like a Silbermann instrument. *Gottfried Silbermann* (Breitkopf und Härtel, 1953), p. 129.

⁶Peter Williams, *The European Organ 1450-1850* (Bloomington: Indiana University Press, 1966), p. 146.

⁷Bach's orchestrations and their implications for registration are discussed at some length by Thomas Harmon in *The Registration of Bach's Organ Works* (Buren: Uitgeverij Frits Knuf B. V., 1978), pp. 280-303. He concludes: "The general agreement between organ-building, registration, and orchestration practices of the early 18th century confirms that they are not mutually exclusive but are instead strongly interdependent upon one another."

⁸Peter Williams, *A New History of the Organ* (Bloomington: Indiana University Press, 1980), p. 117.

⁹Byron Belt, "AGO National Convention 1980," *The American Organist*, XIV (Aug., 1980), 28.

John David Peterson holds the B.Mus., M. Mus., and A.Mus.D. degrees from the University of Michigan. Prior to joining the faculty of Ohio Northern University at Ada in 1973, he taught at Hastings College. Dr. Peterson holds the A.A.G.O. and F.A.G.O. certificates and is currently Dean of the Lima Area AGO Chapter. He has written in these pages previously on Bach symbolism and the Martin "Passacaille."

Todd Wilson organist



AVAILABLE FOR RECITALS.

Call or write to:
Director of Music
Cathedral of the Incarnation
50 Cathedral Avenue
Garden City, New York 11530
516-746-2955

"His playing . . . was especially worthy of note for its incisive articulation and fiery spirit."

MUSIC. The AGO Magazine

Winner

Grand Prix de Chartres
1978

Annual Competition
1st Presbyterian Church, Ft. Wayne
1977

National Competition
1st Congregational Church, L.A.
1975

AGO Regional Competitions
1973, 1975, 1977

Programs during 1980 included recitals for A.G.O. chapters in Kansas City, Chicago (North Shore), Cleveland, Chattanooga, Toledo and Dayton. Recitalist at upcoming Regional conventions in Buffalo and Toledo.

NEW ORGANS

(see pictures on page 1)

**Trinity Lutheran Church
Greenville, S.C.**

**Organ by Steiner Organs Inc.
Louisville, Kentucky, 1980**

Dedication recitalist: W. Lindsay Smith

The two-manual and pedal organ of 29 ranks is centered in a lowered and completely renovated rear gallery, with some pipework revoiced from the previous Kilgen organ. The case design permits viewing of stained-glass, with choir seating between it and the detached console at the gallery rail. The instrument has mechanical key action, electric stop action, and solid-state capture combination pistons. The case, console, and bench are of stained white oak, with an AGO-style pedalboard. Tuning is in equal temperament, with swimmer-stabilized air pressure of 75 mm.

GREAT

Principal (façade) 8' 56 pipes
Rohrfloete 8' 56 pipes
Octave 4' 56 pipes
Spitzoctave 2' 56 pipes
Sesquialtera II 2/3' 112 pipes
Mixture III-VI 1-1/3' 228 pipes
Trumpet 8' 56 pipes

PEDAL

*Subbass 16' 32 pipes
Principalbass 8' (GT) 32 notes
Gedackbass 8' (GT) 12 pipes
*Choralbass II 4' + 2' 64 pipes
Fagott 16' 32 pipes

*pipework rebuilt and revoiced

SWELL

Spitzgedackt 8' 56 pipes
*Salicional 8' 56 pipes
(1-12 capped, 13-17 Haskell)
*Voix Celeste 8' 44 pipes
Metallfloete 4' 56 pipes
Italian Principal 2' 56 pipes
Quinte 1-1/3' 56 pipes
Mixture II-IV 2/3' 164 pipes
Krummhorn 8' 56 pipes
Tremulant

COUPLERS

Swell to Great
Swell to Pedal
Great to Pedal

**Central Christian Church
Texarkana, Texas**

**Organ by Schudi Organ Co.
Garland, Texas, 1980**

Dedication recitalist: Clyde Holloway

The two-manual and pedal organ of 16 ranks has mechanical key action, with electric stop action, and a detached, reversed console. The casework is of solid Honduras mahogany with carved pipeshades. The façade contains the low twenty pipes of the Praestant 8'.

GREAT

Praestant 8' 61 pipes
Rohrfloete 8' 61 pipes
Octave 4' 61 pipes
Blockfloete 2' 61 pipes
Mixture IV 2' 244 pipes

Swell to Great

SWELL

Gedeckt 8' 61 pipes
Rohrfloete 4' 61 pipes
Nasard 2-2/3' 61 pipes
Principal 2' 61 pipes
Tierce 1-3/5' 61 pipes

Tremulant

PEDAL

Subbass 16' 32 pipes
Principal 8' 20 pipes (low 12 GT)
Fagott 16' 32 pipes

Great to Pedal
Swell to Pedal

**St. Peter's Episcopal Church
Phoenixville, Pennsylvania**

**Organ by Austin Organs Inc.
Hartford, Conn., Op. 2644**

The two-manual and pedal organ of twenty-three ranks is located at the side of the chancel, with Great and Pedal divisions in a functional display, and Swell division behind. Charles L. Neill, representative for the firm, was in charge of contract negotiations.

GREAT

Principal 8'
Bourdon 8'
Octave 4'
Koppelfloete 4'
Super Octave 2'
Fourniture II-IV
Cromorne (TC) 8'
Cymbelstern
Tremulant

SWELL

Rohrgedeckt 8'
Gemshorn 8'
Gemstorn Celeste (TC) 8'
Principal 4'
Nachthorn 4'
Nasard 2-2/3'
Blockfloete 2'
Tierce 1-3/5'
Larigot 1-1/3'
Trompette 8'
Tremulant

PEDAL

Principal 16' (GT ext)
Rohrbourdon 16' (GT ext)
Principal 8'
Gedeckt 8' (SW)
Choralbass 4'
Gedeckt 4' (SW)
Mixture II
Trompette 16' (SW ext)
Cromorne 4' (GT)

**First Church of Christ,
Congregational
Suffield, Connecticut**

**Gress-Miles Organ Co.
Princeton, New Jersey, 1980**

The three-manual and pedal organ of 51 ranks has mechanical key action with electric stop action and a complete complement of solid-state pistons and reversibles. It represents the builders' attempt to apply the latest historical research to an instrument for the service and for important styles of literature; it contains influences from 18th- and 19th-century French and German builders, as well as contemporary Americans. The rear-gallery case is of Brazilian mahogany, with pipeshades, mouths, and moldings trimmed in gold. Principals of the Great, Pedal, and Positiv are in the façade. The detached console allows room for singers but retains much of the mechanical advantage of a suspended action. An unusual feature is the horizontally-mounted Positiv rollerboard under the pedalboard. Trackers are of basswood, with inert fittings and rollers, and self-adjusting square rails. The cam-type couplers do not move coupled keys. The bone-covered keyboards with double scorings, rounded edges, and japanned sides are after Dom Bédos. Sharps, pedal sharps, and natural fronts are of rosewood.

A weighted, single-rise reservoir feeds each division with 2 3/8" windpressure, while the 16' basses have a separate supply. A "Flexible Wind" stopknob disconnects the eight concussion bellows. Reeds are based on Dutch and French examples, with wide tongues, open shallots, and full scales. A slightly unequal temperament of 1800, attributed to Thomas Young, was employed. The building enjoys favorable acoustics.

GREAT (I)

Holzgedeckt 16' 49 pipes (12=PD)
Principal 8' 61 pipes
Traversfloete (poplar) 8' 61 pipes
Octave 4' 61 pipes
Spillfloete 4' 61 pipes
Superoctave 2' 61 pipes
Mixture IV-VI 1-1/3' 330 pipes
Trumpet 8' 61 pipes

POSITIV (II)

Montre 8' 61 pipes (12 Haskell)
Gedeckt 8' 61 pipes
Principal 4' 61 pipes
Rohrfloete 4' 61 pipes
Octave 2' 61 pipes
Quintfloete 1-1/3' 61 pipes
Sesquialtera II 122 pipes
Scharf III-IV 2/3' 232 pipes
Cromorne 8' 61 pipes
Tremulant

COUPLERS

Swell to Positiv
Swell to Great
Positiv to Great
Swell to Pedal
Positiv to Pedal
Great to Pedal

SWELL (III)

Bourdon 8' 61 pipes
Viola de Gambe 8' 61 pipes
Voix Celeste (GG) 8' 54 pipes
Spitzfloete 4' 61 pipes
Nasat 2-2/3' 61 pipes
Waldfloete 2' 61 pipes
Tierce 1-3/5' 61 pipes
Plein Jeu III-V 2' 269 pipes
Dulzian 16' 61 pipes
Trompette 8' 61 pipes
Hautbois 8' 61 pipes
Clairon 4' 61 pipes
Tremulant

PEDAL

Principal 16' 12 pipes
Subbass 16' 32 pipes
Principal 8' 32 pipes
Gedeckt bass 8' 12 pipes
Choralbass 4' 32 pipes
Mixture V 2' 160 pipes
Posaune 16' 32 pipes
Trumpet 8' 12 pipes

**Trinity Evangelical Lutheran
Church
Waukesha, Wisconsin**

**Organ by Wicks Organ Co.
Highland, Illinois**

The two-manual and pedal organ of twenty-two ranks has slider chests with electric pull-downs. The elevated placement avoids the use of any floor space. Thomas Gieschen of River Forest, Illinois, designed the instrument and assisted in its voicing and finishing.

GREAT

Principal 8' 61 pipes
Gedeckt 8' 61 pipes
Octave 4' 61 pipes
Koppelfloete 4' 61 pipes
Mixture III 183 pipes
Trumpet 8' 61 pipes

PEDAL

Subbass 16' 32 pipes
Principal 8' 32 pipes
Octave 4' 12 pipes
Rauschquinte II 64 pipes
Fagott 16' 32 pipes

SWELL

Rohrfloete 8' 61 pipes
Flute douce 8' 61 pipes
Flute douce Celeste (TC) 8' 49 pipes
Spitzfloete 4' 61 pipes
Nasat 2-2/3' 61 pipes
Hohfloete 2' 61 pipes
Terz 1-3/5' 61 pipes
Quinte 1-1/3' 61 pipes
Krummhorn 8' 61 pipes
Tremolo

Here & There

THE STAR OF BETHLEHEM, an oratorio by Joseph Rheinberger (1839-1901), was performed Dec. 14 at the First Presbyterian Church of Lancaster, PA. Joining the host choir was the choir of St. James Episcopal Church; Reginald Lunt was the conductor and Frank McConnell was the organist.

RICHARD W. SLATER is the composer of a setting of Psalm 43, "Give Judgement for Me, O Lord," which was premiered recently in California. Mr. Slater was organist for the performance, which took place at the Episcopal Church of SS. Peter and Paul in El Centro.

Miracles at Christmas by NED ROEM received its first performances on Dec. 13 and 14 at the Washington Cathedral. Paul Callaway was the conductor.

THE PLAY OF DANIEL was performed three times during November and December at Trinity Cathedral in Cleveland. Daniel Hathaway and Timothy Tavcar conducted the medieval music drama.

An expanded choir recruited specifically for the occasion performed the Vivaldi *Gloria* on Dec. 7 at the Church of the Covenant, Cleveland, Ohio. From time to time, this church has invited singers who are not regular choir members to join in the performance of a particular large-scale work under the direction of J. Heywood Alexander.

CHARLES BENBOW was the featured artist at a mid-winter music festival held by the Pasadena AGO chapter on Jan. 11 and 12. Mr. Benbow appeared first as a harpsichordist, with a lecture-demonstration on Bach's *Goldberg Variations*, followed by a performance of the complete work. The next day he played a recital of organ works by Messiaen, Bach, Vierne, Wuorinen, and Dupré. The festival was held at the Presbyterian Church in Pasadena, CA.

AGO REGIONAL CONVENTION INFORMATION			
Area	Date	Artists	Contact
Portland, ME	June 28-July 1	Jensen, Lagacé, Parker, Raver, Stephens, Walter, Yohn	Portland AGO 159 State Street Portland, ME 04101
Buffalo, NY	June 28-July 2	Bigham, Fuller, Headlee, Raver, Saunders, Sutherland/Bryn-Julson, Weir, Wilson	Jeanne Lawless 270 Comstock Avenue Buffalo, NY 14515
Wilmington, DE	June 21-24	Dashnaw, Murray, Smith, Walker, Weir, Wojtasiewicz	Harrison Walker 2204 Foote Rd. Fairfax, Wilmington, DE 19803
Birmingham, AL	July 20-23	Brock, Conner, Ludlow, Mueller, Spillman, Thomas, Turnbull, Weir, Wissler	Joseph Schreiber 3100 Highland Ave. Birmingham, AL 35205
Toledo, OH	June 15-17	Gustafson, Hecklinger, Lawrence, Paukert, Porter, Wilson, Wolcott	Norma Kelling 1901 Colony Drive Toledo, OH 43614
Milwaukee, WI	June 15-17	Brunelle, Burmeister, Disselhort, Ditto, Kull, Luther, Rowley, Stevlingson, Saunders, Scoggin, Stapleton	Mrs. Earl Wagner 5235 South 44th St. Milwaukee, WI 53220
Ft. Worth, TX	June 15-18	Anderson, Bedford, Cloak, Logee, Rhodes, Schober, Speller, Williams	Fran Kerlin 1817 Elms Rd. East Ft. Worth, TX 76116
Walla Walla & Richland, WA	June 14-17	Brainard, Glass, Hancock, Neswick, Ritchie, Schuneman, Wright	Mary Esther Lippold 5200 West 26th Ave. Kennewick, WA 99336
Chico, Marysville, & Sacramento, CA	June 22-26	Bovet, Britton, Coulter, Fenstermaker, Moe, Nanney, Rothe, Vogel, Welch, Wood	Jan Peterson 1104 Neal Dow Ave. Chico, CA 95926

A second annual FESTIVAL OF COMPOSERS was sponsored by the Pasadena Chamber Orchestra in January at the First Methodist Church in the California city. Under the direction of Robert Kenneth Duerr, the festival focused on the life and music of Handel, with a performance of the oratorio *Belshazzar* and lectures by Paul Henry Lang.

A memorial concert honoring the late JOSEPH MICHAUD was held Oct. 5 at the National Shrine of the Immaculate Conception in Washington, DC. Mr. Michaud, who died a year earlier, had formerly been music director of the shrine. Robert Shafer conducted the chorus and instrumentalists in works of Bach, Langlais, Messiaen, Michaud, and Victoria.

W. THOMAS SMITH led an Interdenominational Hymn Singing Workshop Nov. 8 for the Long Beach AGO chapter in California, held at Grace Methodist Church in Long Beach. Among the topics discussed in the all-day event was "New sounds in hymn-based organ music," subtitled "Fresh sounds for tired ears."

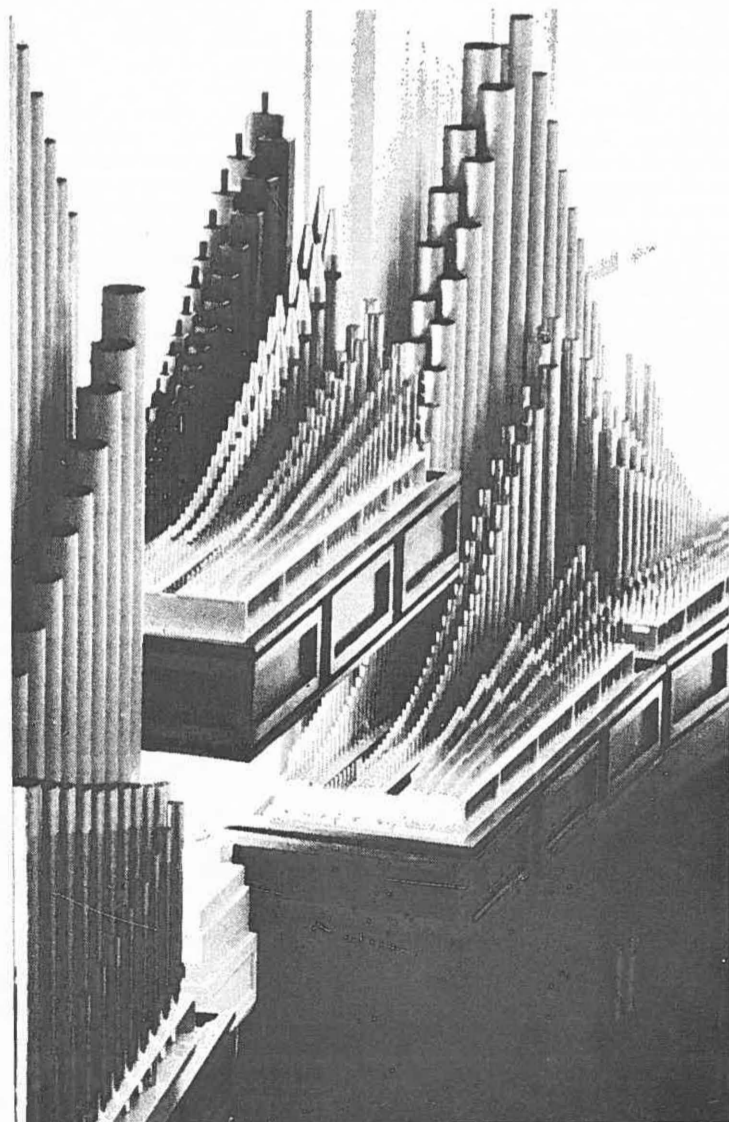

Indiana University School of Music
and
Westminster Choir College
announce a joint

CHURCH MUSIC WORKSHOP June 8-12, 1981

to be held on the Indiana University
campus in Bloomington, Indiana

Faculty:

Indiana

Mary Goetze
Wallace Hornibrook
Wilma Jensen
Oswald Ragatz
Charles Webb

Westminster

John Kemp
Helen Kemp
Erik Routley
Ray Robinson

For further information, write: Special Sessions,
IU School of Music, Bloomington, IN 47405

The Graphic Representation of Repeating Mixtures

by Ch.-W. Lindow

translation by Homer D. Blanchard

The term "repeating Mixtures" obviously relates to:

1) the so-called crowns of the organ, such as Mixtur, Scharf, Zimbel, Corona, Major and Minor Mixture, Fourniture, Plein-Jeu, Ripieno, Lleno, and/or

2) the coloring, mostly high-pitched clusters of mutations of modern organbuilding, which of necessity repeat frequently at the limit of audibility, such as Paletta, Unruh, Stabspiel, and Gong. Insofar as they repeat, the old instrumental-imitators (Kornett, Sesquialtera, Terzian, Carillon) are likewise to be grouped here. We shall refrain from dealing with them, however, because they get along with a single repetition point (such as c^1 in small instruments).

Not much is expressed by the usual statement of the pitch at low C (e.g., "4-6 rank, 1-1/3', or IV-VI, 1-1/3'"). This gives no information whatever about the construction of the mixture (kind of repetition, distribution of the repetition points, upper and lower limits, regroupings, shifts in relationship from 8' to 16', bottlenecks, note spreads,¹ double ranks).

By the time of the *Blockwerk* organ, the mixtures were already multi-ranked. Hence a complete representation of them was necessary, at least in the organ workshops, as a basis for pipe layout. Thus, among others, the drawings of Arnaut von Zwolle are preserved (Cathedral of Dijon, 1440). The table, which, moreover, is very difficult for the uninitiated to grasp, indicates over the entire keyboard all the notes that sound when a key is struck.²

The tables of Dom Bédos — laid out very minutely in a monumental stratification of lines of notes — also indicate the plenum buildup on each individual key, but they afford no sort of overview whatever. They are, moreover, difficult to find room for and presuppose much tedious work at the drawing board. The outlay is not worthwhile.

Later, people hit upon simplified tabular representations, such as we still encounter in technical journals and organ inventory reports. The note structure is merely indicated on the keys where the repetition occurs, which is sufficient for a complete grasp of what is going on. In these the foot pitches are related each time to low C (even if the rank does not begin until later).

Here and there — especially in old shop records — one runs onto tables with actual pipe lengths or pitches on the keys where the repeat begins. In modern organbuilding, however, they are hardly valid.³

Such tables can easily be inserted in a printed text, but they, too, lack direct visual impact. The reader simply skips over these rows of numbers. (Gross errors are often handed down unnoticed from one edition to another.) A mixture sounded good or bad. Everything else was a matter of mysterious secret formulas known only to the trade, and the inquisitive organ lover — yes, even many an occasional stoplist drawer-upper — had to make the best of it.

Let us mention next a representation with horizontal lines drawn to show the various ranks (for example, in Ellerhorst's *Orgelkunde*⁴), which depicts quite well the stratification of the ranks as well as their stepped transposition, but which otherwise gives no information about pitches and the general configuration of the timbre. Apparently this system found little acceptance.

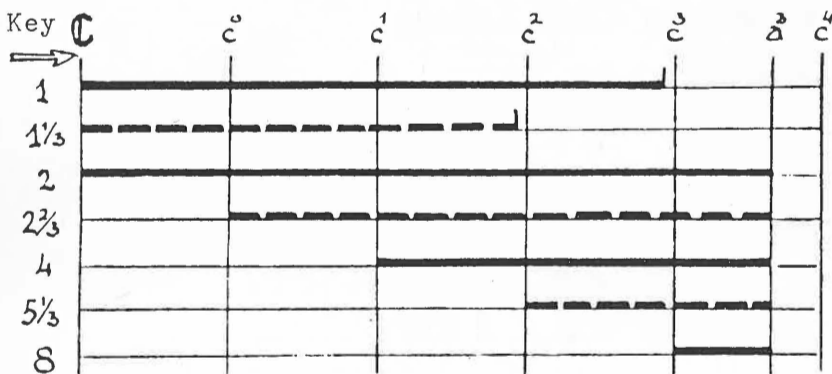

Fig. 1. "Graphic representation of a 3-5 rank Mixture." (Ellerhorst)

In the course of intensive research concerning the plena-structures during the post-war period, people turned to more pretentious graphic representations. These were, to be sure, only outlines with arbitrarily applied criteria, which made no use of linear plotting, but for making comparisons and generalized commentaries they served well as supplements to the texts. (Fellot, Supper, Hardouin, *et al.*)

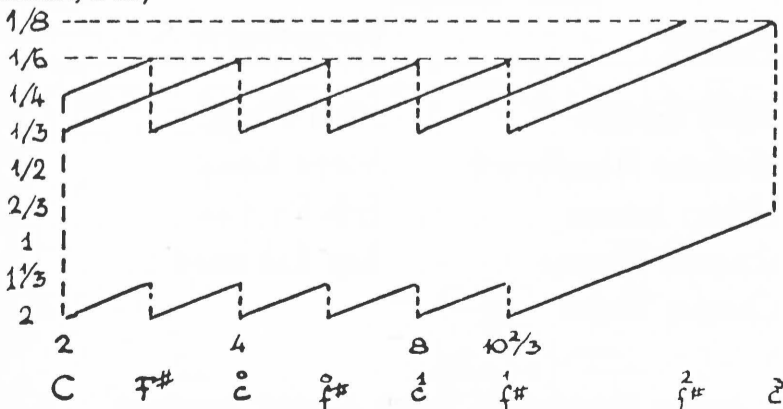

Fig. 2. Auch/Cathedral. Fourniture VI + Cymbale IV. Joyeuse, 1688. (Fellot)

As the final stage in the development, complete diagrams should be considered.

In a recently published model⁵ the ranks run parallel to the keyboard, but, on the other hand, the pitches (not drawn in) run diagonally, so that the so-called limit of audibility (better said: the foot pitch considered for the moment as extreme for organbuilding — in French: "Plafond") drops off toward the treble. One can scarcely orient oneself without making some drastic adjustments.

Another manner of representation is based on the analogies now firmly anchored in our cultural circle: low notes at the bottom, high notes at the top (as on musical staves), bass to the left, treble to the right (as in keyboards and fingerboards). In addition, similar pitch levels line up on horizontal lines while the ranks ascend toward the right — hence toward the treble — which also corresponds to reality. With this in mind a grid was designed which greatly facilitates setting up a mixture diagram. It may, however, be considered to be only an improvement or refinement of older models.⁶

(See the blank form sheet on the facing page.)

The purpose of the printed form shown here and the possibilities for its application may be seen readily from the diagrams below. Countless experiments have shown that stretching out the keyboard division (2 to 1) makes the whole thing easier to grasp. Moreover, an elementary, optically-based logic demands this extension, for on the vertical scale of pitches we have — without taking into account the rare Tierces — 16 pitches for ranks, while we have to find room for 61 notes on the keyboard scale. This arrangement, furthermore, leaves room on a standard size sheet for other information as well.

The three-part box in the upper right gives information at a glance about the makeup of the division concerned. In the first box ("Basis") one notes the basic or acoustic pitch level of the division, and next to it in brackets, the actual pipe length of the foundation voice having the lowest pitch on low C (e.g., 16' [8'] for a Gedackt 16'). For half-covered voices (rare as the basis for a division) one sets down median values without trying to be painfully accurate (e.g., 6' for a Rohrbordun 8'). Then, in the second box ("Prins."), the Principal framework (e.g., 8' + 4' + 2' or 4' + 2'). Finally, in the last box, the number of voices. [Voice = an entity of tone under one indivisible control, one or more ranks of pipes. Rank = a full-range set of pipes. Stop = console mechanism drawing borrows, duplexes, extensions, voices, etc.] Do not think that these requirements are merely some idle fondness for numbers. Whoever has to do with concepts and with comparisons knows full well that without these particulars — which one has to scrape together so laboriously afterward — no fair evaluation is thinkable. We see at once that a Fourniture that is 16' related because it has a 5-1/3' starting on f^1 , is a special case if it is in a division that does not extend below 8' (as in French organbuilding).

The line marked "Type" (= kind, class) should, if necessary, contain a definition, because the stop-name frequently gives no idea of construction and tonal resources, or because often — especially for foreigners — it really tells one nothing: e.g., Klingende Zimbel (= "Cymbale-Tierce"), Paletta, Lleno, Corona. Careful defining, incidentally, clears up different and ambiguous designations. Note that there is space to record the wind pressure at both the reservoir and at the chest, which may be different in some instances.

At the bottom right — for the purpose of alphabetical arrangement in vertical files — there is a repeat of the place name and possibly that of the church, or other, especially if there are several organs in the locality.

Making the diagram proceeds fastest with a good felt-tip pen for the thick lines for the ranks (drawn first in pencil) and with a ballpoint for finer entries and captions.

Keeping clarity in mind, the Octave ranks are drawn in solid lines, while the Quints are drawn in broken lines. A wavy line producing a more drastic effect is proposed for the Tierces. One should save dotted lines for use as "emergency extensions" for pipe ranks that have been removed, for presumed omissions in data gathering, or for desirable supplementary information.

In the case of double ranks, the rank running throughout stays on the printed line for that rank. The rank that comes in at a repeat should be put underneath it so that the pitch of the peaks (that is, on the last note before the repeat) corresponds to reality. On the other hand, in case a Mixtur and a Zimbel are represented at the same time, the doubling of ranks caused by the Zimbel should logically lie above the Mixtur ranks. One should make it a point to avoid multi-colored diagrams because they are mostly disappointing when reproduced. One gets along very well with lines of different widths. A reddish-brown grid [Lindow has experimented widely with this color] shows up clearly in photo-copies. Cold colors (blue, green) would disappear in many copy-machine copies.

In the representation of old, multi-ranked *Blockwerke* all ranks cannot be drawn throughout. The treble of a Ripieno also causes problems. One then simply indicates the number of ranks on a wide, collective line.

Printed lines are lacking for Septimes and Nones because we did not want to overload the grid. In the rare instances where these occur they can be inserted approximately between Octaves, Quints, and Tierces.

The ranks that do not run throughout end on the key [note] before the repeat. One should not forget the vertical line between the two notes: it clarifies the visual picture.

The setting up of a scheme by means of a graph flows easily from one's pen. One checks off the individual ranks on the printed form (best if done from top to bottom) and draws them, one after another, on the grid. In so doing the mixture actually constructs itself. Typographical errors or mistakes in data gathering strike the eye at once. In two instances the schematic called attention to gross blunders made during a restoration.

For the sake of completeness, one can designate the notes where repeats occur in couplable divisions by means of heavy arrows underneath the diagram, or one can make a running note of the proportion of octaves to quints (quintiness!).

ONLY AN ORGAN THIS ADVANCED COULD SOUND LIKE IT WAS MADE A CENTURY AGO.

Baldwin presents a classical organ that's, quite simply, decades ahead of time.

A classical organ designed to produce unsurpassed ensemble for service playing and congregational singing. With advanced microprocessor technology for longer life and reduced maintenance.

The Baldwin 635 SilentTouch™ Organ. A classic combination of art and science.

The science of sound. The magnificent sound of the Baldwin 635 originates in a multiple tone generator system. Featuring a total of four tone generators instead of the one or two found in comparably priced organs.

And, oh, what a sound it is. Rich. Full. Inspiring. With outstanding clarity and brilliance.

And you can make that sound do wonderful things.

Because the Baldwin 635 comes with a full complement of couplers for expanded tonal variety. Multi-channel amplification for greater acoustical flexibility. And the unique CathedraSonic pipe amplification system for a sound dispersion that rivals the tonal integrity of the pipe organ.

The technology of performance. The Baldwin 635 is engineered to provide maximum reliability.

Microprocessor technology replaces mechanical drawknobs and sets a new standard of dependability and instant response.

The exclusive SilentTouch feature assures registration changes with no noise. No hesitation. No delay.

And, because there are fewer mechanical parts to the 635, it requires far less maintenance and virtually eliminates component failure.

The art of leadership. The remarkable Baldwin 635 is available only through your Baldwin Master Organ Guild dealer.

These carefully selected and thoroughly trained dealers are fully qualified to help you select the classical organ that most completely meets your needs. Their knowledge, experience and service capabilities assure expert installation, reliable performance, and fast, dependable service.

All backed by Baldwin's 118-year reputation for leadership in keyboard excellence. Play the Baldwin 635 SilentTouch.

Hear art and science in perfect harmony.

Baldwin Piano & Organ Company
P.O. Box 2525 Dept. D-4
Cincinnati, Ohio 45201



Send me more information and the name of my Baldwin Master Organ Guild dealer.

I enclose \$3 for "Sounds of Faith" recording featuring Model 635.

NAME _____

ORGANIZATION _____

ADDRESS _____

CITY _____ STATE _____ ZIP _____

Baldwin®

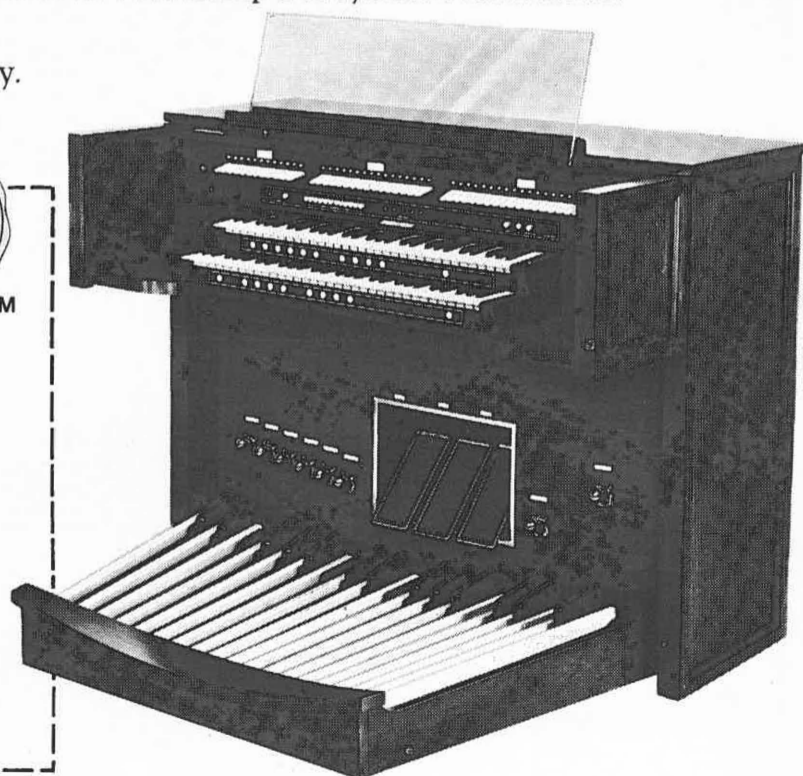

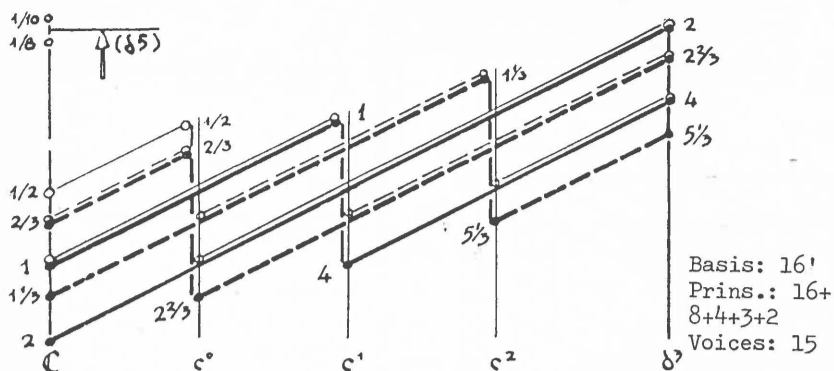

Fig. 4. Dresden/Hofkirche. Mixture IV + Zimbel III. (Hauptw. 51n.). G. Silbermann, 1750-1754.

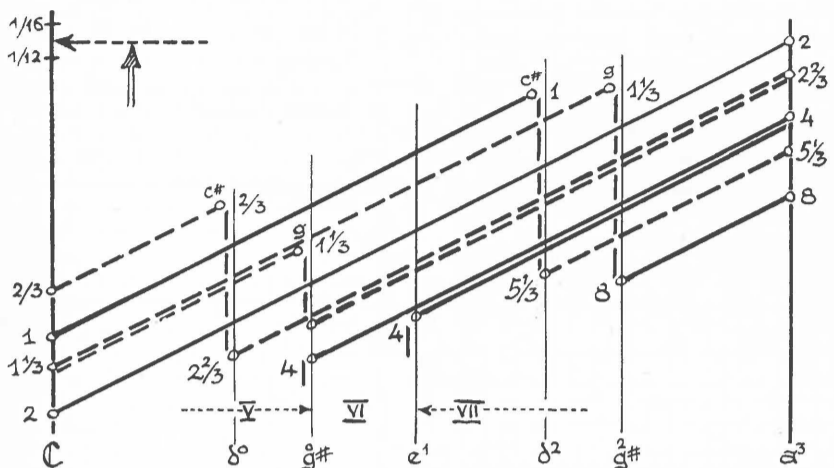

Fig. 5. Würzburg/Cathedral. Grossmixture V-VII. (Hauptw. 58n.). Johannes Klais, 1968-1969. A Fourniture ascendante.⁷

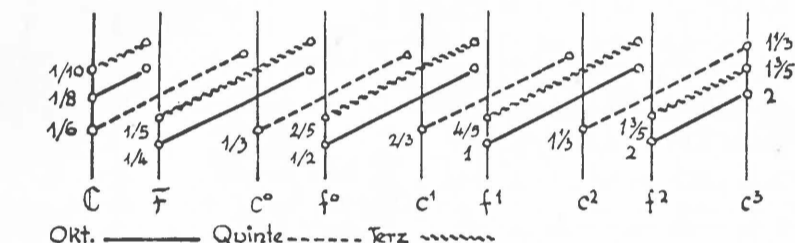

Fig. 6. Hamburg/St. Jacobi. Terz-Zimbel III. Arp Schnitger, 1688.

The Graphic Representation of Repeating Mixtures

(continued from p. 21)

Moreover, one quickly sees that there can be no compromise on any single note channel, and that the great quint (5-1/3'), already coming in on f¹ in a Hauptwerk Fourniture, mercilessly hacks to pieces many a polyphonic phrase. On the other hand, the hectic picture of repeats breaking back an octave makes clear the radical changes in the right hand that are so unpleasant to sensitive ears.

Still other peculiarities show up clearly on the schematic, as, for example, the gradation of the repetition in modern organbuilding (but already tried experimentally by Clicquot), which we call "reprise en chicane" [zigzag repetition] or "reprise différée" [delayed repetition]. These new additions to our vocabulary, to be found in various explications, prove that the diagrams have helped us to new knowledge.

It might be objected that these diagrams would often require too much space in journals. In preparing graphs for use in publications one would generally avoid having the entire form printed. One would trim it: at the bottom, underneath the horizontal 2' or 4' line or underneath the designation "Keys"; at the right next to the foot pitch numbers or next to the last key of the keyboard under consideration; and at the top above the highest repetition points. After any necessary reduction, which is not difficult, the diagrams can then be used as text illustrations in technical journals.

For simplified representations — they can, by the way, turn out to be very pleasing — one places the grid on the drawing board [or light table] and makes a tracing of the mixture schematic. The keys where repetition occurs, as well as other desired inscriptions, are then drawn in by hand (as in an article by H. Klotz).

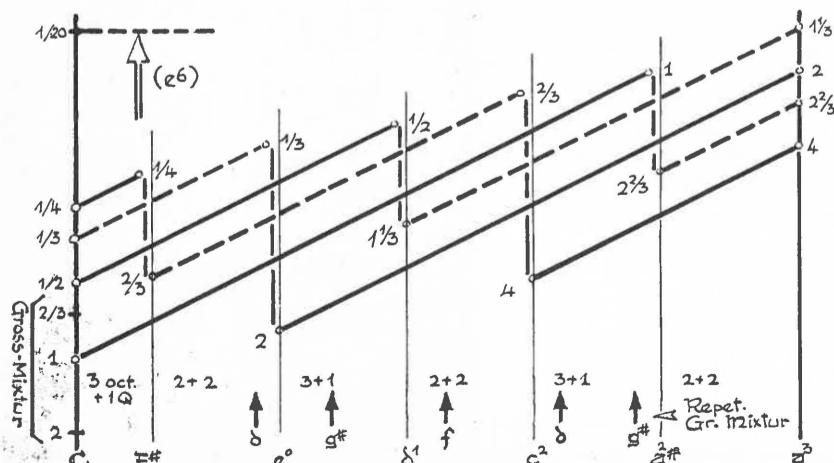

Fig. 7. The Mixture form sheet (simplified version) as used by Ch.-W. Lindow to record the facts about Würzburg/Cathedral. Acuta IV. (Hauptw. 58n.). Johannes Klais, 1968-1969.

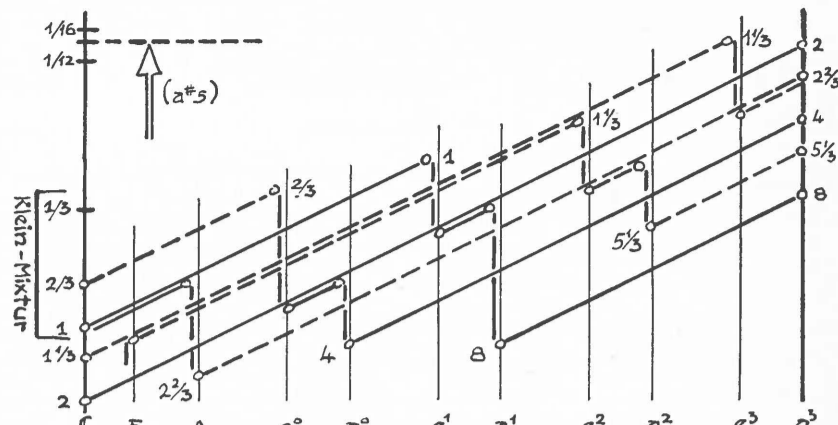

Fig. 8. The Mixture form sheet (simplified version) as used by Ch.-W. Lindow to record the facts about Ulm/Cathedral. Gross-Mixture V-VI. (Hauptw. 58n.). Walcker, 1969.

Other possible applications should be mentioned briefly:

1) One can read acoustical foot-pitches or absolute pitches directly from the grid. Examples: a 3-1/5' rank measures 2-2/3' on D#, 2' on G#, etc.; a 2' length is what a 2-2/3' rank is on F, a 3-1/5' rank on G#, a 4' rank on c°, etc.; one hears the note c⁴ on f¹ if a 1-1/3' is drawn, on g#⁴ with a 3-1/5', etc. (Exact coincidence on the points in the grid).

2) The grid has proven to be a welcome aid in making an inventory of an instrument. On windchests that have been plundered or where pipes are not laid out or distributed uniformly, one notes what is there, one division after another or, if necessary, note by note (e.g., heavy dots for existing pipes, empty circles for borings without pipes, little crosses or randomly chosen letters for replacements made during restorations). Thus one avoids involved, scribbled notes that, as experience shows, cannot always be deciphered easily even a week after the inventory was made. Furthermore, what exists shows up more clearly on the grid. Obviously, this procedure is applicable to all the voices in an organ (Principals, solo labials, individual mutations, reeds). Of course it is really worth the trouble only in so-called "hopeless" cases.

In Oldenburg [1974] the *Gesellschaft der Orgelfreunde*, as part of the picture exhibit, mounted a series of about fifty diagrams on a large display board. Somewhat later all of the Mixtures in the organ in Sinzig were presented in the new format in the brochure about that instrument. A large German organ firm uses the forms for its designs. In France, Pierre Hardouin works only with schematized representations as a matter of principle (see the series of articles about plenum-forms in the journal *Connaissance de l'Orgue*), and several organologists have subscribed to the new system. A first French edition of the forms is already out of print. One may hope, therefore, that the Mixture grid will gradually find acceptance in technical circles and in the literature.

Actual practice has shown that in the case of illustrations for texts it is better to draw the diagram on industrial tracing paper, using the grid as an underlay. In so doing only the most important numbers (foot pitches) and notes need appear. That way the diagram has a more appealing effect and is easier to grasp at a glance. A reduction to 3/4 or even to 1/2 is possible, assuming that the captions do not turn out too small.

NOTES

¹"Note spread" = the distance between the lowest and the highest pitched ranks of a Mixture. Measured in octaves, fifths, fourths, or semi-tones, or also in absolute foot pitches (directly readable on the left edge of the Lindow grid). Applicable to the entire Mixture if it proceeds regularly or to the sections of the Mixture between repetition points: spread and reduction. A modern tonal crown (e.g., Mixture + Zimbel) usually begins very "widespread" and ends in the high treble, or, by necessity, at a bottleneck. Dom Bédos, on the other hand, maintains the same note spread throughout the entire keyboard.

²Christhard Mahrenholz, *Die Berechnung der Orgelpfeifenmessungen* (Kassel: Bärenreiter Verlag, 1938).

³Winfried Ellerhorst, *Handbuch der Orgelkunde* (Einsiedeln, Switzerland: Benziger & Co., 1936), p. 236.

⁴Hans Gerd Klais, *Reflections on the Organ Stoplist*, trans. by Homer D. Blanchard (Delaware, OH: The Praestant Press, 1975), p. 48.

⁵For example, Martin Lange, *Kleine Orgelkunde* (Kassel: Bärenreiter Verlag, 1955).

⁶Compare the graphic with the tabular representations of this same Mixture, the first from *L'Orgue* (Paris), 1972, No. 142, the second from Hans Gerd Klais, *Die Würzburger Domorgeln* (Frankfurt a. M.: Verlag Das Musikinstrument, 1970), p. 76.

C	2	-	1/3	-	1/3	-	1	-	2/3
d°	2 2/3	-	2	-	1/3	-	1/3	-	1
g#°	4	-	2 2/3	-	2 2/3	-	2	-	1 1/3 - 1
e¹	4	-	4	-	2 2/3	-	2 2/3	-	2 - 1 1/3 - 1
d²	5 1/3	-	4	-	4	-	2 2/3	-	2 2/3 - 2 - 1 1/3
g#²	8	-	5 1/3	-	4	-	4	-	2 2/3 - 2 2/3 - 2

C	2'	1 1/3'	1 1/3'	1'	2/3'
d	2 2/3'	2'	1 1/3'	1 1/3'	1'
gs	4'	2 2/3'	2 2/3'	2'	1 1/3'
e¹	4'	4'	2 2/3'	2 2/3'	2'
d²	5 1/3'	4'	4'	2 2/3'	2 2/3'
gs²	8'	5 1/3'	4'	4'	2 2/3'
	14	20	38	30	44
			38	58	44
				20	38
					14

Ch.-W. Lindow was born in Seltz, near Wissembourg in northern Alsace, but moved to Paris at the age of nineteen. At the time of his retirement in 1975 he was Central Inspector for the National Telecommunications Administration. He was a member of the team that founded the AFSOA, the French Association for the Preservation of Old Organs.

He has lectured in the Institut de Musicologie, Paris, on the use of mutations in organbuilding, and he has published widely. The original article in German appeared in *Ars Organi*, 50, June 1976, pp. 2843-49. The Lindow form sheets are available in the U.S. from The Praestant Press, Delaware, Ohio.

Here & There



The building which houses the Schoenstein Organ Company in San Francisco was recently designated as an official San Francisco Landmark and was entered on the National Register of Historic Places by the Department of the Interior. The factory was built in 1928 for the California firm which was founded in 1877. Pictured above (left to right) are Lawrence Schoenstein, State Senator Milton Marks, owner Jack Bethards, Mrs. Gertrude Platt of the city Landmarks Board, Bertram Schoenstein, and City Supervisor Carol Ruth Silver.

ROBERT ANDERSON was the organist for a concert celebrating the 25th anniversary of the installation of the D. B. Johnson memorial Aeolian-Skinner organ at Winthrop College in Rock Hill, SC. Works of Tournemire, Marchand, Bach, Bolcom, Vierne, and Reger were featured on the Oct. 17 program. The late Virgil Fox was the first recitalist on the 4/68 instrument, which is played regularly by college organist David Lowry.

THOMAS MURRAY was the organist for a program sponsored by the Los Angeles

AGO chapter on Nov. 7 in memory of the late Irene Robertson. In addition to playing a recital at the First Congregational Church, Mr. Murray spoke on "The Mendelssohn School of Composers."

A concert of music by HERMAN BERLINSKI honored the composer's 70th birthday on Nov. 16 at St. Margaret's Episcopal Church in Washington, DC, when the composer was organ soloist. Stephen Ackert directed the choir in the first performance of *Song of Unity*, a cantata written for the occasion.

Appointments



John Gouwens has been appointed organist and carillonneur at Culver Military Academy and Culver Girls Academy in Culver, IN. A graduate of the University of Michigan, he is working on his master's degree at the University of Kansas, where he is a carillon student of Albert Gerken. His organ teachers have been Richard Carlson, Clyde Holloway, and Robert Glasgow.

Mr. Gouwens won the Indianapolis Symphony young artist competition when in high school; in 1979 he was the runner-up in the Fort Wayne competition. His duties at Culver include teaching piano, organ, and carillon, as well as playing organ and carillon for chapel services. He will oversee the rebuilding of the academy's 51-bell Gillett and Johnston carillon.



David A. J. Broome has been appointed Vice President and Tonal Director of Austin Organs, Inc., in Hartford, CT. He began his organbuilding career in 1949 with J. W. Walker & Sons of London, coming to America in 1957 to join the Austin firm. He became head reed voicer in 1959, head flue and reed voicer in 1970, and assistant tonal director in 1974. Upon the retirement of Richard J. Piper in 1978, Mr. Broome was given the position of tonal director. Since joining the Connecticut firm, he has finished over seventy organs and has been responsible for many more.

Wilmer Hayden Welsh has been appointed director of music at Davidson College, where he succeeds the late Donald B. Platt. Mr. Welsh earned bachelor's and master's degrees at the Peabody Conservatory, where he was an organ student of Richard Ross and Paul Callaway. He will continue his duties as organist and music professor at the North Carolina institution, where he has taught for 20 years.

ACADEMY OF ITALIAN ORGAN MUSIC PISTOIA 1981

directed by Luigi Ferdinando Tagliavini

Courses:

1. Introduction to the Italian organ (Umberto Pineschi; 21-22 August).
2. Organ (Luigi Ferdinando Tagliavini; 23 August-2 September; works by Merulo, Trabaci, Salvatore, Storace; for two instruments: Porta, Frescobaldi).
3. Harpsichord (Colin Tilney; 23 August-2 September; works by Frescobaldi, Merulo, Salvatore, Strozzi, Trabaci; for two instruments: Porta, Frescobaldi).
4. Tuning and maintenance of the harpsichord (Franco Barucchieri, 24-28 August).

Fees:

Course 1: Lit. 20.000
 Active participant courses 1 & 2: Lit. 200.000
 Active participant course 1, auditor course 2: Lit. 100.000
 Active participant course 2, auditor course 1: Lit. 120.000
 Auditor courses 1 & 2: Lit. 60.000
 Course 4: active participant Lit. 70.000; auditor Lit. 40.000

Concerts during the courses:

Philidor (baroque woodwinds & harpsichord ensemble); Frans Brüggen-Gustav Leonhardt (baroque flute & harpsichord); Jaap Schröder-Colin Tilney (baroque violin & harpsichord); Jan Willem Jansen, Luigi Ferdinando Tagliavini, Monteerrat Torrent Serra (organ).

There will be also Seminars and organ excursions.

Write for further information to the

ACCADEMIA DI MUSICA ITALIANA PER ORGANO
 VIA DELLA MADONNA 28
 51100 PISTOIA, ITALY

Summer Organ Institute

The University of Kansas, June 14-19, 1981

Master classes in performance; seminars in fingering, touch, and articulation using the 71-rank Reuter recital hall organ and new two-manual tracker by Hellmuth Wolff.

Recitals by artist-faculty.

Tuition: \$75 per credit hour for non-residents of Kansas; \$35 per credit hour for Kansas residents.

Low cost University housing available.

For more information, housing reservations and repertoire lists, write:

Dr. James Higdon
 School of Fine Arts
 The University of Kansas
 Lawrence, KS 66045

Opening recital by James Moeser on new Gabriel Kney, four-manual tracker, Sunday, June 14 8:00 p. m. Grace and Holy Trinity Cathedral, Kansas City, MO.

Crozier

Craighead

Albright

Higdon

Moeser

♦ SIMPLICITY—ACCESSIBILITY—RELIABILITY—TONAL SUPERIORITY—DURABILITY—QUALITY ♦

AUSTIN ORGANS, INC.
ORGAN ARCHITECTS AND BUILDERS

Since 1893

156 WOODLAND STREET—HARTFORD, CT. 06105 (203) 522-8293
MEMBER: ASSOCIATED PIPE ORGAN BUILDERS OF AMERICA

♦ ACCESSIBILITY—DEPENDABILITY—QUALITY—TONAL SUPERIORITY ♦

♦ TONAL SUPERIORITY—DURABILITY—QUALITY—SIMPLICITY—ACCESSIBILITY—RELIABILITY ♦

fine leather shoes for organists
Organmaster Shoes



Fast UPS Delivery

WOMEN'S whole and half sizes 4-10
MEN'S whole and half sizes 6-15

CALL OR WRITE (203) 238-7078
90 Fowler Ave., Meriden, Ct. 06450

Fine Hardwood Music Stands . . .

Early Music Stands makes the finest in hardwood music stands, upholstered performers benches, instrument stands, and much more. For your copy of our new 32 page mail order catalog of chamber music furniture, please send \$1 (refunded on first order).
Drawer 550, Box 277, Palo Alto, CA 94302



Roy Redman

Pipe Organ Builder
2742 Ave. H
Fort Worth, Texas 76105
Tele. (817) 536-0090

**STEINER
ORGANS**

Incorporated

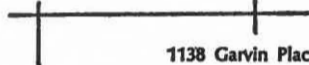

1138 Garvin Place
Louisville, Kentucky 40203

RODGERS

**CHURCH
ORGANS**



Pipe Organs, Augmented or Standard. Rodgers remains the choice of discriminating organ committees as well as leading organists. Built to AGO standards, Rodgers offers the most complete organ in all its price ranges.

Installed in

**SAINT ANDREW'S
EPISCOPAL CHURCH**

Madison, Connecticut

The Reverend James D. Schulthess,
Rector

Marilyn W. Ace,
Organist-Choirmaster

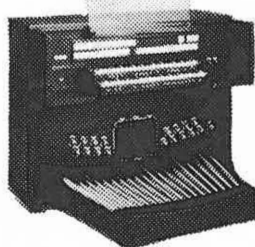

ALEXANDRIA 810

**RODGERS
Organ
Showroom**

Call or write for complete information.

Telephone (212) 582-0032

Out of town, call collect

154 WEST 57th STREET (at CARNEGIE HALL) NEW YORK, N. Y. 10019
OPEN DAILY from 11 to 5 — Other Times By Appointment

Appointments



Ron Neal has been appointed music director for Woods Memorial Presbyterian Church in Severna Park, MD. He leaves a position at Central Presbyterian Church in Lafayette, IN. Mr. Neal holds the M.M. degree in church music and organ from Westminster Choir College, where he was an organ student of Joan Lippincott. He has also studied with Ann McGlothlin Lilly and Marie-Claire Alain, and at the Royal School of Church Music. In his new position he will direct the 70-voice senior choir and will develop a dance and instrumental program.

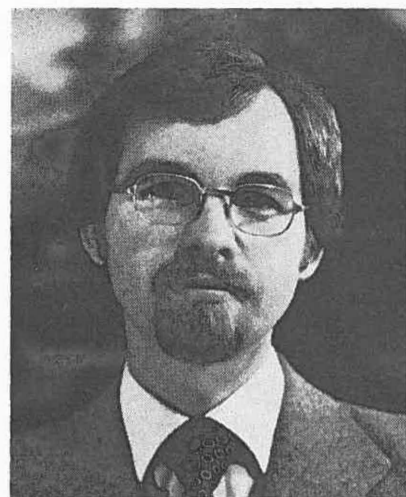

Bruce Gustafson has accepted a position at Franklin and Marshall College, Lancaster, PA, where he will teach music history and be active as a harpsichordist and organist, beginning this fall. He leaves a similar position at St. Mary's College, Notre Dame, IN, where he founded a successful biennial "Harpsichord Weekend." Although harpsichord activity at the Indiana institution will conclude with his departure, he plans to initiate similar events at Franklin and Marshall. He also leaves the position as organist of the First Church of Christ, Scientist, in Elkhart. He will continue to serve as Contributing Editor for *MusicoLOGY* for *The Diapason*.

Mr. Gustafson is the author of *French Harpsichord Music of the 17th Century* and of numerous articles and reviews. He is currently completing an edition of the Bauyn Manuscript co-edited by Peter Wolf, and has begun a source study of 18th-century French harpsichord music co-authored with David Fuller. He will be a duo recitalist with Arthur Lawrence at the forthcoming Toledo regional AGO convention, and he was recently a judge for the Fort Wayne organ competition and for the Kalamazoo Bach Festival young artist auditions.

Mr. Gustafson has been an organ student of Kathryn Loew, Danford Byrens, and Mildred Andrews Boggess. He holds the B.A. from Kalamazoo College, the M.Mus. in organ from the University of Oklahoma, and the A.M.L.S. and the Ph.D. in musicology from the University of Michigan. He has also studied at the Friedrichs Alexander Universität, Erlangen, Germany; the Summer Organ Academy, Haarlem, Holland; and the Université Internationale d'Été de Versailles in France.



Wesley L. Forbis, music chairman and professor at William Jewell College in Liberty, MO, has been elected secretary of the Southern Baptist Sunday School Board's church music department. He succeeds William J. Reynolds, who served in that position from 1971 to 1980. Mr. Forbis earned undergraduate and graduate degrees from the University of Tulsa and from Baylor University, and holds the Ph.D. in music education from George Peabody College.

Thomas Klug has been appointed organist-choirmaster of Olivet Congregational Church, UCC, Saint Paul, MN, where he succeeds Marion and Virginia Seller. The Sellers directed the church music program for 36 years and have been named emeritus music directors. Mr. Seller will be curator of musical instruments and Mrs. Seller will teach and prepare the children's choirs.

Mr. Klug is a graduate of the Lawrence University Conservatory in Appleton, WI, and earned his master's degree in organ and church music at Northwestern University. He has previously served churches in Wisconsin, Illinois, and Minnesota. Olivet Congregational Church houses a 2/33 mechanical-action organ built in 1976 by Lynn Dobson of Lake City, IA.

John-Paul Buzard has been appointed curator of organs at the University of Illinois School of Music in Urbana. He has apprenticed with area organbuilders and managed his own maintenance business previously. Mr. Buzard holds the M.Mus. degree in church music from Northwestern University and has studied organ with Gerald Hamilton at the University of Illinois.

Kim Armbruster has been appointed chairman of the Commission on Liturgy and Church Music for the Episcopal diocese of San Diego. Mr. Armbruster serves as music director for St. Dunstan's Episcopal Church in San Diego.

The *Organ*, the English quarterly published for many years in Bourne-mouth, has announced that Douglas R. Carrington will be its new editor, effective with the current year. Mr. Carrington is a founding member of the British Institute of Organ Studies. He succeeds Bryan Hesford in the editorial position.

Announcements

Stetson University School of Music, DeLand, FL, recently received the first installment of a collection of organ recordings that will ultimately number in the thousands when transfer of the gift is completed. The collection was assembled by Douglas Johnson, Professor of Pharmacology at the University of Georgia in Athens. As a Florida native, he was interested in establishing a recorded organ archive in the southeast. The initial gift contained 204 78 rpm discs, and 268 lp discs.

These new archival materials at Stetson provide information about organists, instruments and performance practices of bygone eras. There are performances by Louis Vierne and Charles-Marie Widor in France; Alfred Sittard and Günther Ramin in Germany; Guy Weitz and Goss-Custard in England; Mark Andrews and Charles Courboin in America. Vierne was recorded improvising and also playing Bach at Notre-Dame Cathedral, Paris (1930). Widor recorded the Toccata from his Fifth Organ Symphony at St. Sulpice, Paris (1932). Ramin played Bach at St. Thomas Church, Leipzig, and Sittard was a noted interpreter of Reger. Goss-Custard documented the English cathedral style at Liverpool Cathedral, and Courboin was well-known for his Franck performances. Early recordings of organ with orchestra are also represented, and the 78 rpm discography of E. Power Biggs is essentially complete in the collection. G. Donald Harrison's first 78 rpm lecture on the American classic organ is included, as are early performances by many organists who were later documented with more modern recording techniques. Organists in this category include Marcel Dupré, André Marchal, Fritz Heitmann, Fernando Germani, and Virgil Fox.

Many organs documented on old 78 rpm recordings no longer exist. The discs of this collection that are least significant musically are perhaps most important in terms of their rarity and as documentation of a lost aspect of pipe organ performance. These are a small group of recordings of popular songs made on the studio organs of America's early radio stations.

Stetson's new collection of early organ recordings will be available for study by those interested in historic organ performance. It is hoped that the collection will also attract gifts of related materials to expand holdings in this area.

Historic St. Luke in the Fields Episcopal Church in the Greenwich Village area of New York City was substantially damaged by a three-alarm fire in the early hours of Mar. 7. The 1821 Federal-design structure was the third-oldest church building in Manhattan and was virtually destroyed; only the walls and tower remain. The Rev. Ledlie I. Laughlin Jr., rector, has already indicated that the church will be rebuilt. It had contained a 2/25 Casavant mechanical-action organ installed only a year ago in the rear gallery; the instrument received favorable notice in press accounts but is thought now to be a total loss.

The Organ Club of England will make an eleven-day tour of organs on the east coast of the US in October. About fifty members of the organization are expected to make the tour, which will be based in Washington, Lancaster, Philadelphia, and New York City. The group includes professional and amateur church musicians, organbuilders, and other interested persons; the tour is being coordinated by Jonathan Rennert.

26th Annual National Convention

THE ORGAN HISTORICAL SOCIETY

June 22 through June 25, 1981

Orono, Maine (metro. Bangor) and surrounding area.

Organs by Henry Erben, E. & G. G. Hook, Hook & Hastings, E. L. Holbrook (rebuilt: Noack), Emmons Howard, George S. Hutchings, E. W. Lane, George Stevens.

Demonstrations/Recitals by Marion Anderson, Sue Armstrong, William Aylesworth, David Bergeron, George Bozeman Jr., Nina Hollifield, Earl Miller, Rosalind Mohnsen, Barbara J. Owen, Charles Page, Lois Regestein and Elizabeth Sollenberger. Concluding recital by Karel Paukert.

For details and registration, contact: Charles Ferguson, Registrar
Box 44
East Vassalboro, ME 04935

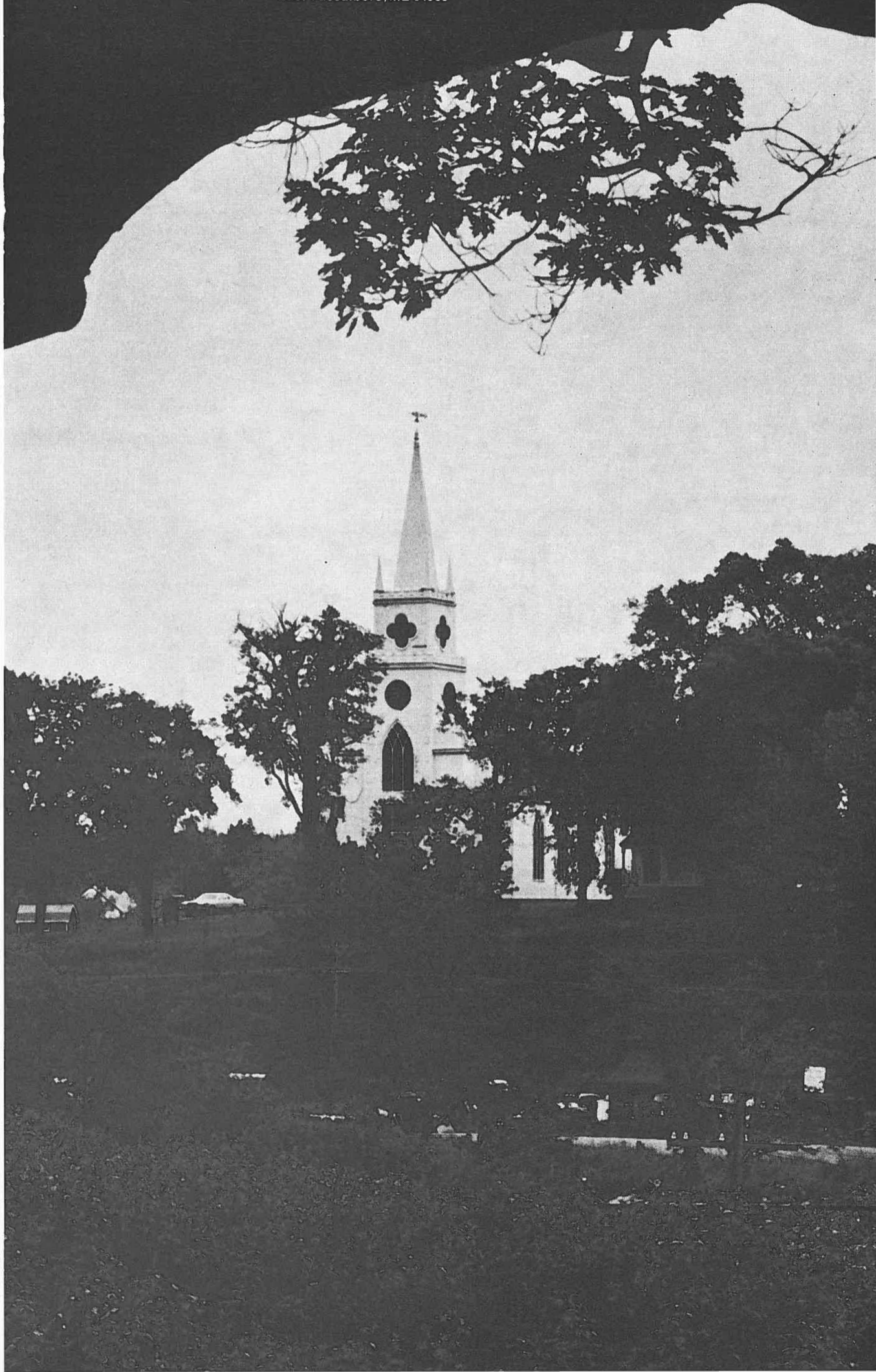

The Quiet One

MEIDINGER virtually eliminates the mechanical, electrical, and aerodynamic noise found in other blowers with these exclusive features:

- Special MEIDINGER-designed bronze sleeve bearings.
- Motor/rotor and cam wheel dynamically balanced.
- The unique electrical design of the blower motor practically eliminates magnetic noise sources.
- Special MEIDINGER-designed inlet sound silencer.
- Aerodynamically shaped spiraled housings and bladed cam wheel.

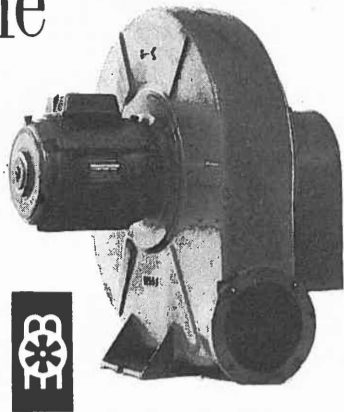

G. Meidinger & Cie.

BASEL, SWITZERLAND

**KLANN
ORGAN SUPPLY**

EXCLUSIVE U. S. DISTRIBUTOR
Post Office Box 2398 • Waynesboro VA 22980
(703) 949-8737

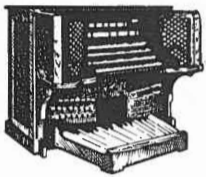

Casavant Frères Incorporated

a subsidiary of
CASAVANT FRERES LIMITEE
St. Hyacinthe, Quebec, Canada

Complete Pipe Organ Services

new organs rebuilding chimes maintenance

serving

Texas Oklahoma Arkansas Louisiana

offices in Plano and Houston

2512 Westridge Drive
Plano, Texas 75075 (214) 422-7337

3402 Blalock #3919

(713) 460-0119 Houston, Texas

There's one thing in our plant that hasn't changed in 83 years . . . our pride.

Reisner is people . . . specialists who really care about their craft. Reisner is old-fashioned work ethics and modern technological brain power. Our attitude hasn't changed . . . only our products. They keep getting better.

Pipe organ parts
and consoles by

REISNER

240 N. Prospect Street
Hagerstown, Maryland 21740
301/733-2650



Featured Concerts at the Ann Arbor Organ Conference

reviewed by

Anne Parks

Festival Choral Service (American Guild of Organists in conjunction with the Univ. of Michigan), Oct. 19, 1980, Zion Lutheran Church, Ann Arbor.

A service of lessons and carols surveying the church year opened the 20th annual Organ Conference at the University of Michigan. Many practical ideas for church choirs and congregations were presented in the course of the two-hour service.

Some of the most effective ideas were the simplest — a processional on "Veni Emmanuel" was introduced and accompanied for four verses by bells, the introduction beginning with only two notes in alternation, later verses with the fifths above these notes, and then, alternating chords. As the procession ended the congregation and organ joined in the final verses of the hymn. For another hymn — the Passion Chorale — the congregation was asked to read a verse silently as a chorale prelude by Bach was played on the organ.

Several voluntaries for bells, played by the Bethlehem Bell Choir were extremely effective for this medium. The *Toccata in A Minor* by Mary G. McCleary displayed a variety of textures including staccato as well as dynamic variety. *Carillons* by Langlais, arranged by Glenn Shields Daun, used tones sustained so long they blended like organ tones, as well as using an unusual tremolo technique.

Four local organists, Carol Muehlig, Joy Schroeder, Donald Williams, and Mary Ida Yost, provided lengthy preludes and postlude and a variety of introductions and accompaniments for hymns. The *Two Chorale Preludes on 'Veni Emmanuel'* by Alec Wyton using diatonic dissonances would be a fine prelude to Advent services in many churches. In the first chorale prelude the melody of the chorale is developed and expanded over an ostinato figure. The second employs a dissonant chordal introduction based on the first four notes of the chorale. Many of the hymns were introduced with short chorale preludes, including the Zachau *Chorale Prelude on 'In Dulci Jubilo'* from *Eighty Chorale Preludes* and Jan Bender's *Chorale Prelude on 'Wie Schön Leuchtet'* from the *Festival Collection*. Many of the hymn accompaniments included brass descants — some improvised by trumpeter Jim Nissen. Other excellent hymn introductions and accompaniments were improvised by organist Donald Williams.

The combined choirs of eight local churches presented four anthems conducted by featured conference guest Alec Wyton. These anthems, on themes scattered throughout the church year, were all of moderate to easy difficulty and would be practical for many church choirs. *Jesus, So Lowly* by Harold Friedrich, an a cappella passion anthem, was especially effective.

Marilyn Mason, organ, William Albright, narrator, Oct. 20, Hill Auditorium.

Marilyn Mason's recital on the second evening of the conference featured contemporary music by American composers. Her performance was characterized throughout by flair and sympathy for the music. The program was well-balanced, opening with a relatively conservative piece and concluding with a humorous one.

The Ann Arbor premiere of Persichetti's *Dryden Liturgical Suite, Op. 144*, commissioned by the Marilyn Mason Commissioning Fund of the University of Michigan and dedicated to Marilyn Mason, opened the program. This relatively traditional series of variations on a hymn melody, *Dryden*, by Persichetti, is basically diatonic with mild dissonance. The varied meters reflect the flexible shape and phrasing of the melody rather than any strongly accented rhythm. Many of these movements would be suitable for use in worship services as well as in recital. The first movement, "Prelude: By whose aid the world's foundations first were laid . . .", *Religioso*, alternates a chorale-like texture with two-voice counterpoint. The "Response: Give us Thyself, that we may see . . .", *Ben Misurato*, uses three-voice counterpoint with each phrase opening in free imitation reminiscent of the fore-imitation style of chorale settings. The third movement, "Psalm: From sin and sorrow set us free . . .", *Con spirito*, is more often homorhythmic with some two-voice counterpoint and a more brilliant ending. The "Prayer: Make us eternal truths receive . . .", *Sostenuto*, is chorale-like in texture. The final movement, "Toccata: In flame and fire our hearts . . .", *Brillante*, is showy and exciting with the arpeggios and figuration typical of toccatas. Mason's playing showed a flexibility in shaping phrases, which is needed for this music.

William Albright's *Organbook II*, commissioned by and dedicated to Marilyn Mason, displayed Mason at her best. Her fine sense of musical gesture resulted in an effective and thrilling performance. The work was conceived for a large, romantic organ such as the one in Hill Auditorium. In this work the performer's sense of timing is crucial since the notation is spatial and the performer must judge durations not only by the relative space on the page, but also by a sense of how long a given musical gesture should be in the context. "Night Procession," the first movement exploits the softest sonorities of the organ with slowly changing timbres, dynamics, voicing, and chords. "Toccata Satanique" exploits the techniques of tremolo and trill as well as cluster glissandi. "Last Rites" for organ and electronic tape consists of "blocks of sound juxtaposed and overlaid."¹ Mason's superb performance of this challenging work was received by the audience with great enthusiasm.

The world premiere of Leslie Bassett's *Liturgies*, also commissioned by the Marilyn Mason Commissioning Fund and dedicated to Marilyn Mason, opened the second half of the program. While following the tradition of the

service music of Frescobaldi in choosing the sections of liturgical music to set, Bassett has written a work in a style related to those of Ross Lee Finney and William Albright.

Basset's "Kyrie" is more brilliant than most Kyries, being designated as "Bright" in tempo and displaying block chords, toccata-like flourishes, and sustained arpeggios. (Each note of the broken chord is sustained after its arrival.) The "Gloria," designated "Brilliant" by the composer, uses toccata-like runs and chord tremolos, as well as sustained arpeggios. The "Offertory" — "Gentle" — again uses sustained arpeggios with other techniques. The "Trinity" is represented by a "three-in-one canon" with a chromatic melodic style — the only movement with prominent melodic interest. The "Elevation of the Host" is the closest to Albright — it is reminiscent of the final movement of his *Organbook I* and also achieves a mood similar to that of Frescobaldi's elevations. This movement opens with a gradually transformed chord — one note at a time is changed — and also features chords built gradually by the addition of one note at a time. The ending on a major triad comes as a surprise. The final movement, "Benediction — Postlude" is a "Homage to Widor," reminding one of the Toccata from Widor's *Fifth Symphony* with its rapid arpeggio-like figuration in the right hand and rhythmic repeated chords in the left. Mason's performance featured colorful and appropriate registrations and rhythmic flexibility in her interpretation.

The finale of the concert was Albright's humorous *The King of Instruments: A Parade of Music and Verse* for which the composer served as narrator. Mason made a comic entrance, carried in on a chair and wearing a crown and unmatched shoes. Albright's work has short verses and musical excerpts for each of the divisions of the organ and each class of stops. The purpose, however, is not to educate the listener, but to amuse — puns and rhymes on the names of stops are as important to the excerpts as the stop itself. Perhaps the best verse of the text was "The Clarion needs Marion, The Fagott does not." The Blues — played on the flues — were especially well received.

The careful balance of the program gave this audience at an all-contemporary program an opportunity not only to hear a variety of recent styles, but also the chance to enjoy the program with great enthusiasm.

Ernst Ludwig Leitner, organ, Oct. 21, Concordia Lutheran College Chapel.

Ernst Ludwig Leitner, Professor of Music at the Mozarteum, Salzburg, Austria, on his first visit to the United States, presented a program ideally suited to the basically Germanic Schlicker organ of the Concordia College Chapel.

Leitner's clean playing in the Muffat *Passacaglia* exhibited crisp articulation in the Walcha tradition, but perhaps was bit too detached for the room. His strong sense of rhythm reminded this reviewer of the rhythmic freedom with control exhibited by Anton Heiller late in his career.

Mozart's *Adagio, Allegro [and Adagio]*, K. 594, was registered with appropriate lightness. In the *Adagio* Leitner displayed a sensitive motivic slurring. The clarity of his ornaments was especially admirable as was his sense of timing with a subtle ritard before the return to the *Adagio*. However, one wonders why he did not insert a cadenza at the fermata before the return of the *Adagio*.

The Mozart *Adagio* (some editions call it *Andante*), K. 616, was played on 4' stops sounding much like the Haydn pieces for musical clock. In his performance Leitner used subtle freedoms in the rhythm of repeated notes.

Other interpreters might have found appoggiaturas appropriate in the return of the opening section, but such questions do not detract from the delight of this performance.

Leitner's performance of the Mozart *Fantasia in F Minor*, K. 608, was straight-forward on a bright, clear, light registration. The lilting rhythm was a pleasure to listen to. The return to the opening seemed more effective than the original by its contrast with the second section — a tribute to Leitner's sense of proportion in this performance. The rhythm of the final section (the varied repetition of the fugal second section) in Leitner's performance catches up the listener, making one want to move with it. In the conclusion of the piece Leitner built a fine sense of excitement.

The *Toccata and Fugue in F Minor* by Johann Nepomuk David, a 20th-century Austrian composer, was played with great rhythmic flexibility. Leitner's straight-forward, clear performance built up excitement at the conclusion through his treatment of rhythm and registration.

The second half of the program was devoted to Leitner's own works. The premier performance of his *Alleluia* was played with great flair. The *Pastorale*, also being premiered, is a work which begins with fragments and gradually works into motion. Both this and the following piece used bird-call like sounds reminding one of Messiaen. Though a bit radical, the *Pastorale* could be used in a church service as well as in recital. The *Recitative and Hymn on "Christ ist erstanden"*, whose opening section was more like a toccata than a recitative, was played flamboyantly and was enthusiastically received.²

Ernst Leitner's clear, crisp playing of earlier works and flamboyant playing of contemporary ones provided a fine balance in a highly successful concert.

NOTES

¹William Albright, jacket notes to *New Music for Organ*, Nonesuch H-71260. The score is published by Jobert, Paris.

²All three of these works by Leitner are published by Musikverlag Doblinger, Vienna.

Anne Parks, an active organ recitalist who specializes in contemporary music, teaches at the University of Michigan — Dearborn. Dr. Parks holds degrees from Oberlin, Northwestern, and Cornell, and has written previously in these pages on the organ music of William Albright and Ross Lee Finney.

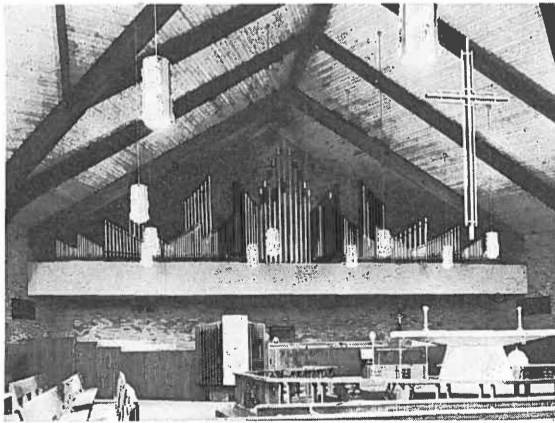

**TRINITY EV. LUTHERAN CHURCH
Mount Clemens, Michigan**

THE WICKS ORGAN COMPANY

HIGHLAND, ILLINOIS 62249

Pipe Organ Craftsmen Since 1906

**Excellence
in pipe organ building
since 1875**

M. P. Möller
INCORPORATED

Hagerstown, Maryland 21740

Phone: 301 — 733-9000

THE REUTER ORGAN COMPANY

Box 486

Lawrence, Kansas 66044

(913) 843-2622

*We build contemporary
TRACKER ORGANS*

Brunzema Organs Inc.

596 Glengarry Crescent South
Post Office Box 219
Fergus, Ontario Canada
N1M 2W8

(519) 843-5450

**THIS THREE-MANUAL
organ of 45 ranks
is in a spacious
loft behind the
choir.**

Great	Positiv
16' Quintadena	8' Gedeckt
8' Principal	4' Rohrflöte
8' Rohrflöte	2' Principal
4' Octave	1 1/2' Spitzquinte
4' Spillflöte	II Sesquialtera TC
2 1/2' Twelfth	IV Scharf
2' Fifteenth	8' Krummhorn
V Mixtur	
8' Trompette En Chamade	Pedal
8' French Trompette	16' Principal
Chimes	16' Subbass
Carillon	16' Bourdon
Cymbelstern	8' Octave
	8' Spillflöte
	4' Principal
	8' Hohlflöte
	8' Koppelflöte
	8' Spitz Gamba
	8' Erzähler Celeste
	4' Holzprincipal
	4' Spitzflöte
	2' Flachflöte
	1' Spitzflöte
	III Mixtur
	8' Fagot
	4' Rohrschalmei
	Tremulant

McMANIS ORGANS

Incorporated
10th & Garfield
KANSAS CITY, KANSAS
66104
A.P.O.B.A. Member



**Builders of Fine Tracker and
Electro-Pneumatic Pipe Organs**

Inquiries are Cordially Invited

W. Zimmer & Sons
INCORPORATED

Member APOBA

Mailing Address: P. O. Box 520, Pineville, N. C. 28134
NATIONS FORD ROAD • CHARLOTTE, N. C.

Brandon



England

J. W. WALKER & SONS · LTD

Mechanical Action Organs in the best English tradition.

American Representative: Dennis Klug

2953 Oxford Av., Lakeland, Florida 33803 Telephone: (813) 665-9105

ORGANS BY

Gabriel Kney

137 FALCON STREET, LONDON, ONTARIO, CANADA. N5W4Z2

Delaware

DELAWARE ORGAN COMPANY, INC.

252 Fillmore Ave.

Tonawanda, New York 14150

(716) 692-7791

MEMBER A.P.O.B.A.

Schantz

ROBERT C. NEWTON
Northern California Representative
Sales and Service

518 Lorraine Avenue
San Jose, CA 95110

Telephone
(408) 998-0455

HARVEY & ZIMMER

Tracker Organ Designers and Builders
P.O. Box 222128 Dallas, Texas 75222

214/946-3493

**BOZEMAN - GIBSON
AND COMPANY
ORGANBUILDERS**

Telephone: (603) 463-7407

RFD one (route 107)

Deerfield, New Hampshire 03037

IT'S OUT!

OUR COMPLETE 68+ PAGE CATALOG
ILLUSTRATED WITH CURRENT PRICE DATA!

SEND \$4.25 TODAY

ARNDT ORGAN SUPPLY COMPANY

1018 LORENZ DRIVE - BOX 129
ANKENY, IOWA 50021

Casavant Frères

DISTRICT REPRESENTATIVE LIMITEE
MICHIGAN, INDIANA, WESTERN OHIO
COMPLETE PIPE ORGAN SERVICES
MICHAEL PERRAULT
P.O. BOX 7191
ANN ARBOR, MI 48107
TEL: (313) 994-4855

(305) 523-7247

WALTER A. GUZOWSKI
PIPE ORGAN SERVICE

Business Home
1121 E. Commercial Blvd. 1225 S.W. 4th Ct., Apt. B
Ft. Lauderdale, Fla. 33334 Ft. Lauderdale, Fla. 33312

ANDOVER
Box 36 Methuen, Massachusetts 01844
Mechanical Action Specialists

since 1845

Rieger

Rieger Organs
A-6858 Schwarzach Austria

KOPPEJAN

pipe organs
Tracker-organ builder
new organs and restoration

48223 Yale Rd E
Chilliwack, B C
Canada V2P 6H4 Phone (604) 792-1623

Sacred Music Convocation

at Davidson College

by Arthur Lawrence

Like many other regional music conferences, the annual Davidson College Sacred Music Convocation has served the central Carolina area well for some time. Under the guidance of college organist Wilmer Hayden Welsh, it has presented important persons and events to the community around Davidson, NC, over the years, celebrating its 20th birthday last Nov. 7-8. Usually it has been organized around the presence of a guest artist who performs and lectures, supplemented by presentations from one or more local or regional personalities. The "theme" has generally dealt with some aspect of organ and/or choral music, incorporating the specialties of the persons involved. Depending on such varied factors as weather, schedules, and what else is going on, attendance may range from few to many, but there is always an interested nucleus present, drawn from students and teachers and from church musicians. Because it subsidizes the costs, the college has probably never made money on such a gathering, but the real point has been to provide a thrust for education in sacred music, and that has certainly been achieved. The organizational model is one which any far-sighted administrator might emulate.

The 1980 convocation was centered around Judith Hancock, the Associate Organist at St. Thomas Church in New York City, who presented two addresses (actually one, in two parts) and a recital. Mr. Welsh organized and played for an unusual but effective service, and organbuilder Ralph Blakely gave a lecture with slides. Two glorious days, resplendent with the autumnal reds, oranges, and yellows of maple leaves and filled with Southern hospitality, complemented the musical events and made the visitors welcome.

The featured recital included the following works: *Toccata, Villancico y Fuga*, Ginastera; *Christ, unser Herr*, BWV 684, Kyrie, *Gott Heiliger Geist*, BWV 671, and *Concerto in D Minor*, BWV 596, Bach; *Prelude and Fugue sur le nom d'Alain*, Duruflé; and *Fantasia on the Chorale "Wie schön leuchtet"*, Reger. Judith Hancock's playing was assured and musical, although I felt that the Bach chorale preludes were marred by dwelling on spots of symbolic significance, which disrupted the rhythmic flow. There were no doubts about the performances of the big romantic works, however — the Ginastera, the Reger, and especially the Duruflé were among the best I have heard this organist play, and they were the outstanding moments of her evening program.

For her addresses, Mrs. Hancock drew on her recent interest in "Symbolism in the Music of Johann Sebastian Bach," dealing with selected organ works and cantata movements. She approached the subject through a dis-

ussion of pictorial symbolism, numerology, and *Affektenlehre*, the background coming from sources as disparate as Spitta and Geiringer. She seemed particularly interested in Bach as metaphysician, and she frequently stressed the importance of understanding Bach's music through his devout and religious personality. In surveying the music, much attention was given to passages of numerological significance. Inasmuch as her presentation lacked thorough knowledge of current Bach research and contained a number of inconsistencies, it seemed wisest to view it as part of a personal odyssey toward interpretation, through symbolic analysis. Hancock radiated enthusiasm for her subject and led a student choir through several cantata movements, as well as the complete Cantata 4.

Mr. Welsh and Mr. Blakely both addressed aspects of Spanish organs and organ music, providing an effective foil to Bach and the Germanic tradition. The organbuilder's lecture with slides was on early Spanish organs and revealed excellent material derived from his own examination of many of the extant Iberian instruments. Mr. Blakely began with background material on the history and construction of the organs, much of which is more involved than the material found in the standard (pro-Northern) texts, so this detail on a subject foreign to most of us was greatly appreciated. He continued with a showing of a number of color slides of Spanish organs, many of which are both handsome and very different from other historic instruments.

The convocation members then adjourned to the Davidson College Presbyterian Church, for a collegiate communion service celebrating the Feast of St. Willibrord (d. 739), with early Spanish organ music drawn from the works of Cabezón, Peraza, Cabanilles, Jiménez, Santa Maria, Moreno, Elias, and Bermudo, as well as anonymous composers. Practicality dictated that the congregation say rather than sing their parts, but the *alternatim* practice was followed, with organ verses provided at all the appropriate moments. Although Mr. Welsh played a modern organ (a large Wicks of special design, which has proven over the past ten years to be well-equipped for most of the literature), he was able to project the special performance characteristics of Spanish organ music in a very exciting manner. This service constituted a high point of the conference and provided those present with many ideas for the use of such music.

When the final Saturday event had concluded, those in attendance had to scatter for their Sunday assignments, but all would attest to the value of such a two-day meeting. Many will undoubtedly return when the 1981 Sacred Music Convocation will feature the Viennese organist Peter Planyavsky.

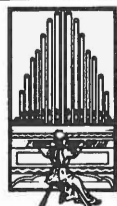

DAVID ROTHE,
California State University, Chico
St. John's Episcopal Church, Chico
Recitals
P.O. Box 203
Forest Ranch
California 95942

Organist

Workshops
(916) 345-2985
895-6128



Calendar

This calendar runs from the 15th of the month of issue through the following month. The deadline is the 10th of the preceding month (May 10 for the June issue). All events are assumed to be organ recitals unless otherwise indicated and are grouped north-south and east-west within each date. *—AGO chapter event; +—new organ dedication. Information will not be accepted unless it specifies artist name, date, location, and hour in writing. THE DIAPASON regrets that it cannot assume responsibility for the accuracy of calendar entries.

UNITED STATES East of the Mississippi

15 APRIL
Tenebrae service; Church of the Advent, Boston, MA 7 pm
Bach *Motet III*; Incarnation Cathedral, Garden City, NY 8 pm
Music of Byrd; St Thomas Church, New York, NY 12:10 pm
Paul-Martin Maki; Alice Tully Hall, New York, NY 5:30 pm
Bach *St John Passion*; Lincoln Center, New York, NY 7:30 pm
Fauré *Requiem*; Bland St Methodist, Bluefield, WV 7:30 pm
Theodore W Ripper; Grace Methodist, Venice, FL 1:30 pm
Michael Krentz; 1st Presbyterian, Deerfield, IL 12:10 pm

16 APRIL
Byrd *Mass for Five Voices*; Church of the Advent, Boston, MA 6:30 pm
Music of Byrd; St Thomas Church, New York, NY 12:10 pm
Josquin *Missa Pange lingua*; St Ignatius Church, New York, NY 6 pm
Beebe *Service*; Bland St Methodist, Bluefield, WV 7:30 pm
Schütz *Seven Words*; Starmount Presbyterian, Greensboro, NC 7:30 pm
Handel *Messiah*; 2nd Presbyterian, Indianapolis, IN 8 pm
Lorraine Brugh; 1st Presbyterian, Deerfield, IL 12:10 pm

17 APRIL
Victoria *Reproaches*; Church of the Advent, Boston, MA 6:30 pm
Victoria *Improperia*; St Ignatius Church, New York, NY 12:30 pm
Way of the Cross; St James the Less, Scarsdale, NY 8:15 pm
Bach *St John Passion*; N Yonkers Community Church, Hastings-on-Hudson, NY 8 pm
Sermons & anthems; St Johns Church, Washington, DC 12 noon
Tenebrae service; Chevy Chase Presbyterian, Washington, DC 7:30 pm
Bach *St Matthew Passion*; Trinity Cathedral, Cleveland, OH 7 pm
Leon Nelson; 1st Presbyterian, Deerfield, IL 12:10 pm
Thomas Weisflog; Rockefeller Chapel, Univ. of Chicago, IL 5 pm
Handel *Messiah II, III*; 4th Presbyterian, Chicago, IL 7:30 pm
Brahms *Requiem*; Rockefeller Chapel, Univ of Chicago, IL 8 pm
Tenebrae service; 1st Presbyterian, Nashville, TN 8 pm

18 APRIL
Music of Excetre, Olyver; St Thomas Church, New York, NY 6 pm
Plainchant *Missa I*; St Ignatius Church, New York, NY 10:30 pm

19 APRIL
Hewitt-Jones *Reconciliation Mass*; Church of the Advent, Boston, MA 6 & 11 am
Organ & brass; Christ & St Stephens Church, New York, NY 10:45 am
Lotti *Missa Duarum Vocum*; St Ignatius Church, New York, NY 11 am
Britten *Rejoice in the Lamb*; St Thomas Church, New York, NY 3 pm
Dvorak *Te Deum*; St Bartholomews Church, New York, NY 4 pm
Bach *Easter Oratorio*; Holy Trinity Lutheran, New York, NY 5 pm
Choral music; 10th Presbyterian, Philadelphia, PA 10:45 am
Karel Paukert; Art Museum, Cleveland, OH 2 pm
Organ & brass; Zion Lutheran, Ann Arbor, MI 8:10 & 10:40 am

20 APRIL
Wilma Jensen; Indiana Univ, Bloomington, IN 8 pm

21 APRIL
William Jones, piano; Trinity Church, New York, NY 12:45 pm
*Ann Bauer & Kristin G Johnson; Centennial ARP, Columbia, SC 7:30 pm
Violin & piano; Christ Church, Cincinnati, OH 12:10 pm
Janette Fishell; 1st Baptist, Bloomington, IN 8 pm

22 APRIL
Music of Willan, Candlyn; St Thomas Church, New York, NY 12:10 pm
Student recital; Indiana Univ, Bloomington, IN 8 pm

23 APRIL
Ma Prem Alimo, soprano; St Pauls Chapel, New York, NY 12:10 pm

24 APRIL
William Albright, ragtime; Colgate Mem Chapel, Hamilton, NY 8:30 pm
Thomas Richner; Union College, Cranford, NJ 8 pm
Keith Chapman; Calvary UCC, Reading, PA 8 pm
Music for 2, 3, 4 organs; National Shrine, Washington, DC 8:30 pm

25 APRIL
William Albright workshop; Colgate Chapel, Hamilton, NY 9:30 am

26 APRIL
Thomas Murray; 1st Church, Nashua, NH 8 pm
Plainsong *Missa Paschalis*; Church of the Advent, Boston, MA 11 am
Choral evensong; Trinity Episcopal, Tariffville, CT 4 pm
Easter chorales; Christ & St Stephen Church, New York, NY 10:45 am
Campra *Missa Ad Majorem*; St Ignatius Church, New York, NY 11 am
Marilyn Keiser; Riverside Church, New York, NY 2:30 pm
Ann I Cooper; St Thomas Church, New York, NY 5:15 pm
William Albright; Colgate Chapel, Hamilton, NY 3:30 pm
Joanne Jasinski w/voice; St Pauls RC, Kenmore, NY 3 pm
Carlo Curley; Primitive Methodist, Birmingham, NY 3 pm
Scott Trexler; Zion Lutheran, Schenectady, NY 7:30 pm
+David Hurd; St Pauls Baptist, Utica, NY pm
Timothy Albrecht; 1st Presbyterian, Bethlehem, PA 7:30 pm
Linda Marquart, soprano; Cathedral of Mary Our Queen, Baltimore, MD 5:30 pm
Christa Rakish; Westminster Presbyterian, Charlottesville, VA 8:15 pm
+James Litton; St Pauls Lutheran, Charleston, WV 4 pm
Choral, instrumental music; 1st Presbyterian, Burlington, NC 11 am
Thompson *Testament of Freedom*; Newberry College, SC 4 pm
Robert Parris; Vinesville Baptist, Macon, GA 3 pm
Karel Paukert; Art Museum, Cleveland, OH 2 pm
Music of Brahms; Trinity Cathedral, Cleveland, OH 5 pm
Music of Vaughan Williams; Trinity Episcopal, Toledo, OH 5 pm
Melvin West; 7th-day Adventist, Kettering, OH 8 pm
Bruce Gustafson & Arthur Lawrence, duo harpsichords; St Pauls Episcopal, La Porte, IN 4 pm
Wilma Jensen; 4th Presbyterian, Chicago, IL 6:30 pm
IPC Choir concert; Independent Presbyterian, Birmingham, AL 4 pm

27 APRIL
*Wayne N Earnest; Bethel Methodist, Spartanburg, SC 8 pm

28 APRIL
Copland *In the Beginning*; Grace Church, Brooklyn Heights, NY 8 pm
Thomas Moore, tenor; Trinity Church, New York, NY 12:45 pm
McNeil Robinson; St Pauls Cathedral, Syracuse, NY 8:15 pm
Handel *Messiah II, III*; Miller Chapel, Princeton, NJ 8 pm
*Wesley Parrott; Westminster Presbyterian, Richmond, VA 8 pm

(Continued overleaf)

robert anderson

SMD FAGO

Southern Methodist University
Dallas, Texas 75275

WILLIAM AYLESWORTH

D. M.

Evanston, Illinois

Workshops Recitals

ROBERTA BITGOOD

S.M.D., F.A.G.O., Ch. M.

13 Best View Road
Quaker Hill, Connecticut 06375

CHARLES S. BROWN

DMA FAGO CHM

North Texas State University
Denton 76203

St. John's Episcopal Church
Dallas
The Denton Bach Society

Robert Clark

School of Music

University of Michigan
Ann Arbor

Harry E. Cooper

Mus. D., F.A.G.O.

RALEIGH, N. CAROLINA

WALLACE M. COURSEN, JR.

F.A.G.O.

GRACE EPISCOPAL CHURCH
ORANGE, N.J.

DAVIDSON

Jerry F. School of Music Susan L. St. Alban's Chapel
Louisiana State University
Baton Rouge

EUGENIA EARLE

Teachers College, Columbia University

Harpichord Recitals
Performance Practice Workshops
15 West 84th Street, New York, N.Y. 10024

KATHRYN ESKEY

The University of

North Carolina

at Greensboro

Robert Finster

TEXAS BACH CHOIR

ST. LUKE'S EPISCOPAL CHURCH
SAN ANTONIO

HENRY FUSNER

S.M.D., A.A.G.O.

First Presbyterian Church
Nashville, Tennessee 37220

CHARLOTTE AND WILLIAM

ATKINSON

FIRST PRESBYTERIAN CHURCH
2001 El Camino Real
Oceanside, California 92054

ORGAN VIRTUOSO

diane bish

SCM International Management
Box 2096
Clearwater, FL 33517
(813) 446-2914

CHARLES BOEHM

TRINITY LUTHERAN CHURCH

Hicksville, N.Y.

NASSAU COMMUNITY COLLEGE
Garden City, N.Y.

DOUGLAS L. BUTLER
DOUGLAS L. BUTLER
DOUGLAS L. BUTLER
DOUGLAS L. BUTLER
DOUGLAS L. BUTLER
MUSICIAN

Concerts, Organ Instruction, Conductor, Consultant
629 S.E. Franklin, #26 / Portland, Oregon 97202
(503) 232-2549

Jeanne Rizzo Conner

Organ-Harpichord

Broward Community College, Florida
Pompano Beach, Florida

Florida Atlantic University,
Boca Raton,
Florida

MICHAEL CORZINE

School of Music

Florida State University
Tallahassee

JOHN EDWARD COURTER

F.A.G.O.

Recitalist

Berea College Berea, Ky. 40404

DELBERT DISSELHORST

DMA

University of Iowa

Iowa City

Iowa

Paul Raymond Emmons

M. Mus. M.S. A.A.G.O.

Grace Church

Ellensburg, Washington

GEORGE ESTEVEZ

ch.m.

Chicago Chamber Choir

JAMES FREY

John W. Gearhart III
B.A., M.Mus.

St. Paul's Episcopal Church
P.O. Box 8427
Mobile, Alabama 36608

Robert Glasgow
School of Music
University of Michigan
Ann Arbor

LESTER GROOM
Seattle

Seattle Pacific University 98119
1st Presbyterian Church 98104

E. LYLE HAGERT

Gethsemane Episcopal Church
Minneapolis, Minnesota 55404

DAVID S. HARRIS

Organist and Choirmaster
St. John's Cathedral
Denver

WILL O. HEADLEE

SCHOOL OF MUSIC
SYRACUSE UNIVERSITY
SYRACUSE, NEW YORK 13210

VICTOR HILL

Harpichord and Organ
Williams College
St. John's Episcopal Church
Williamstown, Mass. 01267

d. deane

hutchison
portland, oregon

ELLEN KURTZ

JACOBSON

M.Mus. A.A.G.O.
Concord, California

CHARLES D. JENKS

First Congregational Church
Des Plaines, IL 60016

BRIAN JONES
Boston 02181

Wellesley Congregational Church
Noble & Greenough Dedham Choral
School Society

ORGAN RECITALS
FRANCIS JOHN KOSOWICZ
"SILFRAN"

13C HARMONY ROUTE
SPENCER, WEST VIRGINIA 25276
304-927-4679

RICHARD W. LITTERST
M. S. M.

SECOND CONGREGATIONAL CHURCH
ROCKFORD, ILLINOIS

Antone Godding

School of Music
Bishop W. Angie Smith Chapel
Oklahoma City University

BRUCE GUSTAFSON

Saint Mary's College
Notre Dame, Indiana

JAMES J. HAMMANN

M.M. - A.A.G.O.
Central Methodist Church
Detroit, Michigan

Dr. Richard Hass
Our Savior's Lutheran
Church
Rockford, Illinois

KENT HILL

MSC Music Department
Mansfield, PA 16933

Harry H. Huber

D. Mus.
Kansas Wesleyan University, Emeritus
University Methodist Church
SALINA, KANSAS

FRANK IACINO

St. Andrew's Church
24 Stavebank Rd.
Mississauga, Canada
Recitals Records

Laurence Jenkins

London
The Sine Nomine Singers

MICHELE JOHNS A.Mus.D.

Organ - Harpsichord
The University of Michigan
School of Music
First Congregational Church
Ann Arbor

KIM R. KASLING

D.M.A.
St. John's University
Collegeville, MN 56321

WILLIAM KUILLMAN

Decorah, Iowa 52101
Luther College

KARYL LOUWENAR

Harpichordist
The Florida State University
School of Music
Tallahassee, FL 32306

Calendar

(continued from p. 29)

29 APRIL

Music of Hancock, Messiaen; St Thomas Church, New York, NY 12:10 pm
Copland In the Beginning; Old 1st Reformed Church, Brooklyn, NY 8 pm
Robert Edward Smith, harpsichord; Christ Lutheran, York, PA 8 pm
Marshall Madrigals; St Johns Church, Washington, DC 12:10 pm

30 APRIL

Avi Yosselevitch, oboe; St Pauls Chapel, New York, NY 12:10 pm
Linda Bliven; Central Congregational, Galesburg, IL 7:30 pm

1 MAY

Warren R Johnson; State St Church, Portland, ME 12:15 pm
Thomas Richner; Biblical Research Foundation, Charlestown, NH 8 pm
John Rose; Trinity College, Hartford, CT 8:15 pm
Robert Edward Smith, harpsichord; Grace Episcopal, Elmira, NY 8 pm
Everyman; Presbyterian Church, Bryn Mawr, PA 7:30 pm
Clinton Miller; St Johns Lutheran, Allentown, PA 8 pm
"Musical Bestiary"; Rockefeller Chapel, Univ of Chicago, IL 8 pm

2 MAY

*David Craighead masterclass; S Congregational, New Britain, CT 1 pm
Everyman; Presbyterian Church, Bryn Mawr, PA 4 pm
G & S Pinafore; Zion Lutheran, Ann Arbor, MI 8 pm

3 MAY

Britten Little Sweep; Trinity Episcopal, Hartford, CT 4 pm
David Craighead; S Congregational, New Britain, CT 7:30 pm
Richard Heschke; Immanuel Lutheran, Bristol, CT 7 pm
Bach Cantata 160; Christ & St Stephens Church, New York, NY 10:45 am
Morales Missa Beata Virgine; St Ignatius Church, New York, NY 11 am
William Self; St Thomas Church, New York, NY 5:15 pm
Canterbury Singers; Congregational Church, Scarsdale, NY 8 pm
Thomas Murray, orchestral trans; West Presbyterian, Binghamton, NY 4 pm
Fauré Requiem; St Peters Church, Morristown, NY 4 pm
Brewer Chamber Ensemble; West Side Presbyterian, Ridgewood, NJ 4:30 pm
Donald Willing; Trinity Cathedral, Trenton, NJ 3:30 pm
Mozart Requiem; Trinity Church, Princeton, NJ 8 pm
Everyman; Presbyterian Church, Bryn Mawr, PA 7:30 pm
Paul Manz, hymn festival; Good Shepherd Lutheran, Lancaster, PA 8 pm
Lloyd Bowers, harpsichord; Cathedral of Mary Our Queen, Baltimore, MD 5:30 pm
Spring concert; Chevy Chase Presbyterian, Washington, DC 4 pm
Choir recognition; Bland St Methodist, Bluefield, WV 9:30 & 11 am
Handbell concert; Church of the Covenant, Cleveland, OH 4:30 pm
Bach Cantatas 4 & 29; Fairmount Presbyterian, Cleveland Heights, OH 7 pm
Peggy Marie Haas; 1st Congregational, Columbus, OH 3 pm
Vaughan Williams C-Minor Mass; 7th-day Adventist, Kettering, OH 8 pm
Three Choir Festival; Christ Church, Cincinnati, OH 4 pm
Huw Lewis; Christ Church Cranbrook, Bloomfield Hills, MI 4 pm
G & S Pinafore; Zion Lutheran, Ann Arbor, MI 3 pm
Arno'd H Sten; 1st Congregational, Battle Creek, MI 8 pm
Double Handbell Concert; 1st Presbyterian, Deerfield, IL 4:30 pm
Edward Mondello; Rockefeller Chapel, Univ of Chicago, IL 8 pm
James A Brinson; Church of the Holy Communion, Memphis, TN 5 pm

4 MAY

*AGO concert; Trinity Church, Newport, RI 7:30 pm
Todd & Anne Wilson; Adelphi Univ, Garden City, NY 8 pm

5 MAY

Dona Buel, piano; Christ Church, Cincinnati, OH 12:10 pm

6 MAY

Music of Byrd; St Thomas Church, New York, NY 12:10 pm
James Kibbie; Alice Tully Hall, New York, NY 5:30 pm
John Bankett; St Johns Church, Washington, DC 12:10 pm
Karel Paukert; Art Museum, Cleveland, OH 12 noon
Opus I Chamber orch; Trinity Cathedral, Cleveland, OH 8 pm

7 MAY

Terry Charles; Kirk of Dunedin, FL 8:15 pm

8 MAY

Joanne Jasinski; St Josephs RC, Buffalo, NY 8 pm
Terry Charles; Kirk of Dunedin, FL 8:15 pm
Opus I Chamber orch; Trinity Cathedral, Cleveland, OH 8 pm
Louisville Bach Soc; 2nd Presbyterian, Louisville, KY 8 pm

9 MAY

Cathedral Chamber Singers; Incarnation Cathedral, Garden City, NY 8 pm
Robert Smart; Wanamaker Grand Court, Philadelphia, PA 11 am
Organ concerti w/orch; St Peter & Paul Cathedral, Philadelphia, PA 3 pm
SC Chamber Orch soloists; Centennial ARP, Columbia, SC 8 pm
Terry Charles; Kirk of Dunedin, FL 8:15 pm
Opus I Chamber orch; Trinity Cathedral, Cleveland, OH 8 pm
Louisville Bach Soc; 2nd Presbyterian, Louisville, KY 8 pm

10 MAY

Britten Rejoice in the Lamb; Christ & St Stephens Church, New York, NY 10:45 am
Mouton Missa Alleluia; St Ignatius Church, New York, NY 11 am
Badinage; Park Ave Christian, New York, NY 2 pm
Daniel Palko; St Thomas Church, New York, NY 5:15 pm
Choral evensong; Trinity Church, Princeton, N 4:30 pm
Phoenix Choir; Cathedral of Mary Our Queen, Baltimore, MD 5:30 pm
Festival of organ music; St Johns Church, Washington, DC 12:30 pm
Two choir concert; Westminster Presbyterian, Charlottesville, VA 4 pm
David Dunkle; Trinity Cathedral, Cleveland, OH 5 pm
Choir festival; Zion Lutheran, Ann Arbor, MI 11 am
Childrens choir concert; 2nd Presbyterian, Indianapolis, IN 8 pm

11 MAY

Music of Tomkins, Harris; St Thomas Church, New York, NY 5:15 pm

12 MAY

Music of Tippett, Berkeley; St Thomas Church, New York, NY 5:15 pm
Grubich Duo; Trinity Cathedral, Cleveland, OH 8 pm

13 MAY

Music of Haydn, Mozart; St Thomas Church, New York, NY 12:10 pm
Richard Jarvis; St Johns Church, Washington, DC 12:10 pm
Karel Paukert; Art Museum, Cleveland, OH 12 noon
Milhaud program; Art Museum, Cleveland, OH 8 pm

15 MAY

John Rose; St Pauls Cathedral, Syracuse, NY 8 pm
Gerre Hancock; St Stephens Church, Columbus, OH 7:30 pm

16 MAY

RSCM choral festival; St Lukes Church, Evanston, IL 4 pm

17 MAY

Keiko Bartosik, piano; Trinity Church, Newport, RI 4 pm
Mixed concert; Trinity Episcopal, Tariffville, CT 4 pm
Mozart Exsultate Jubilate; Christ & St Stephens Church, New York, NY 10:45 am
Berkeley Missa Brevis; St Ignatius Church, New York, NY 11 am
John Donne Celebration; Church of the Ascension, New York, NY 11 am
Monteverdi Vespers; Madison Ave Presbyterian, New York, NY 4 pm
Wojciech Wojtasiewicz; St Thomas Church, New York, NY 5:15 pm
Collegium Musicum; All Saints Church, Princeton, NJ 8 pm

Spring festival; 10th Presbyterian, Philadelphia, PA 5 pm
 Giovanni DeChiaro, guitar; Christ Lutheran, York, PA 8 pm
 Quentin Faulkner; Cathedral of Mary Our Queen, Baltimore, MD 5:30 pm
 Choir day; Chevy Chase Presbyterian, Washington, DC 8:45 & 11:15 am
 Wayne Earnest; Purity Presbyterian, Chester, SC 3 pm
 Gerre Hancock; Art Museum, Cleveland, OH 4 pm
 Alice Parker concert; Church of the Covenant, Cleveland, OH 7:30 pm
 Guy Bovet; Ohio Wesleyan Univ, Delaware, OH 8:15 pm
 Enrique Arias, piano; Community Church, Park Ridge, IL 4 pm
 Bruckner Mass in E Minor; 4th Presbyterian, Chicago, IL 6:30 pm

18 MAY
 Thomas Murray, lecture-recital; Congregational Church, Woburn, MA 8 pm

19 MAY
 John Rose; Park Church, Elmira, NY 8:15 pm
 Henry Lowe w/trumpet; Christ Church, Cincinnati, OH 12:00 pm
 Choir concert; St Pauls Episcopal, Indianapolis, IN 8 pm

20 MAY
 Music of Poulenc; St Thomas Church, New York, NY 12:10 pm
 Janice Fehér; St Johns Church, Washington, DC 12:10 pm
 Honegger King David; Emory Univ, Atlanta, GA 8:15 pm
 Karel Paukert; Art Museum, Cleveland, OH 12 noon

21 MAY
 Marianne Webb; Central Congregational, Galesburg, IL 8 pm

22 MAY
 *Wayne Leupold, lecture demonstration; Zion Episcopal, Morris, NY 7:30 pm
 Honegger King David; Emory Univ, Atlanta, GA 8:15 pm
 Chicago String Ensemble; St Pauls Church, Chicago, IL 8:15 pm

24 MAY
 Vaughan Williams Benedicite; Christ & St Stephens Church, New York, NY 10:45 am
 Isaac Missa Carminum; St Ignatius Church, New York, NY 11 am
 Quentin Lane; St Thomas Church, New York, NY 5:15 pm
 Organ and voice; St Pauls Church, Owego, NY 4 pm
 Margaret Lindsay, soprano; Cathedral of Mary Our Queen, Baltimore, MD 5:30
 Donld Williams; St Philips Cathedral, Atlanta, GA 5 pm

26 MAY
 Stephen Hamilton; Huguenot Church, Charleston, SC 10 am
 Margaret Dickinson; Univ of Louisville, KY 8 pm

27 MAY
 Music of Rubbra, Hadley; St Thomas Church, New York, NY 12:10 pm
 Gillian Weir; Alice Tully Hall, New York, NY 5:30 pm
 Albert Russell; St Johns Church, Washington, DC 12:10 pm
 Karel Paukert; Art Museum, Cleveland, OH 12 noon

28 MAY
 Music of Vaughan Williams; St Thomas Church, New York, NY 12:10 pm
 Stephen Hamilton; St Matthew Lutheran, Charleston, SC 10 am

29 MAY
 "Music for a Cathedral Space"; Trinity Cathedral, Cleveland, OH 8 pm
 Vaughan Williams concert; St James Cathedral, Chicago, IL 8 pm

31 MAY
 South Church Choral Soc; S Congregational, New Britain, CT 7:30 pm
 Bach Cantata 37; Christ & St Stephens Church, New York, NY 10:45 am
 Byrd Mass for Three Voices; St Ignatius Church, New York, NY 11 am
 Marsha Long; St Thomas Church, New York, NY 5:15 pm
 Locklair Constellations; 1st Presbyterian, Binghamton, NY 4 pm
 Choir festival; Methodist Church, Red Bank, NJ 10 am
 Quentin Faulkner; National Cathedral, Washington, DC 5 pm
 Catharine Crozier; Art Museum, Cleveland, OH 4 pm
 Hymn festival; Fairmount Presbyterian, Cleveland Heights, OH 7pm
 Stravinsky Les Noces; Rockefeller Chapel, Univ of Chicago, IL 4 pm

UNITED STATES
 West of the Mississippi

15 APRIL
 Charles Ore; 1st-Plymouth Congregational, Lincoln, NE 12:10 pm

16 APRIL
 Vance M Reese; Caruth Aud, SMU, Dallas, TX 8:15 pm

20 APRIL
 *Kathryn Johnson; Northaven Methodist, Dallas, TX 8:15 pm

23 APRIL
 Delores Bruch & Delbert Disselhorst; Univ of Iowa, Iowa City, IA 8 pm

24 APRIL
 Guy Bovet; Univ of Iowa, Iowa City, IA; workshop 9:30 am; recital 8 pm
 Robert Clark; Central Methodist College, Fayette, MD 8 pm
 Paula Price; St Andrews Episcopal, Stillwater, OK 8 pm
 *Albert Travis; St Stephen Presbyterian, Ft Worth, TX 8:15 pm

25 APRIL
 Guy Bovet workshop; Univ of Iowa, Iowa City, IA 9:30 am
 Verdi Requiem; Chandler Pavilion, Los Angeles, CA 8:30 pm

26 APRIL
 Gerre Hancock; Arkansas College, Batesville, AR 4 pm
 English Handbell Choirs; Christ Church Cathedral, New Orleans, LA 4 pm
 Handbell festival; Westminster Presbyterian, Lincoln, NE 4 pm
 Lessons & carols; E Dallas Christian, Dallas, TX 4 pm
 James Walker; St Cross Episcopal, Hermosa Beach, CA 4 pm
 Los Angeles Master Chorale; Chand'er Pavilion, Los Angeles, CA 7:30 pm
 (Continued overleaf)

David Lowry
 School of Music
 Winthrop College
 Rock Hill, South Carolina 29733

William MacGowan
 Bethesda-by-the-Sea
 Palm Beach, Florida

Norman McNaughton
 Recitals
 221 West 57th St.
 New York, N.Y. 10019

WILLIAM H. MURRAY
 Mus. M F.A.G.O.
 Church of the Mediator
 Chicago, Ill.

RICHARD M. PEEK
 Sac. Mus. Doc.
 Covenant Presbyterian Church
 1000 E. Morehead Charlotte, N. C.

JOHN DAVID PETERSON
 Ohio Northern University
 Ada, Ohio 45810

RECITALS
Don Roland
 Suncoast Concert Mgmt. & Productions, Inc.
 P.O. 6374 • Clearwater • Florida • 33518

Robert Shepfer
 Organist - Choirmaster
 SECOND PRESBYTERIAN CHURCH
 Indianapolis, Indiana 46260
 Recitals

L. ROBERT SLUSSER
 MUS. M., A.A.G.O.
 LA JOLLA PRESBYTERIAN CHURCH
 LA JOLLA, CALIFORNIA

Carl Staplin
 Ph.D., A.A.G.O.
 Drake University
 First Christian Church
 DES MOINES, IOWA

JONATHAN A. TUUK
 Immanuel Lutheran Church
 338 North Division Avenue
 Grand Rapids, Michigan 49503
 Recitals

DONALD W. WILLIAMS
 D.M.A.
 Zion Lutheran Church
 Concordia College
 Ann Arbor, MI

BETTY LOUISE LUMBY
 DSM • FAGO
 UNIVERSITY OF MONTEVALLO
 MONTEVALLO, ALA. 35115

FREDERICK L. MARRIOTT
 ORGANIST — CARILLONNEUR
 KIRK-IN-THE-HILLS
 BLOOMFIELD HILLS, MICH. 48013

JAMES R. METZLER
 TRINITY CHURCH
 TOLEDO, OHIO

WILLIAM NESS
 ANDREWS UNIVERSITY
 Berrien Springs, Michigan
 Organ — Church Music

FRANKLIN E. PERKINS
 Ph.D.
 The Ladue Chapel
 The John Busroughs School
 St. Louis, Missouri

Robert M. Quade
 MSM, Hon RSCM
 Organist — Choirmaster
 Saint Paul's Episcopal Church
 1361 West Market Street
 Akron, Ohio 44313

K. BERNARD SCHADE
 S.M.M.
 STATE COLLEGE
 EAST STROUDSBURG, PA.
 Workshops and Lectures
 The Kodaly Choral Method

ROBERT L. SIMPSON
 Cathedral of St. Philip
 2744 Peachtree Road N.W
 Atlanta, Georgia 30305

Robert W. Smith
 Historic First Christian Church
 Charlottesville, Virginia

ADOLPH STEUTERMAN
 Memphis, Tennessee
 Mus. Doc., F.A.G.O.
 Southwestern at Memphis, Retired
 Calvary Episcopal Church, Emeritus

CLARENCE WATTERS
 RECITALS
 Trinity College
 Hartford, Connecticut

DONALD WILLING
 faculty
 North Texas State University
 Denton

MICHEL H. PINTE
 Assistant organist
 at St Augustin
 PARIS



8, rue des Coutures Saint-Gervais
 75003 PARIS

THE DIAPASON

380 NORTHWEST HIGHWAY • DES PLAINES, IL 60016

Name
Street
City
State Zip

- NEW SUBSCRIBER**
Please begin new subscription
- RENEWAL**
(Attach to mailing label)
- ENCLOSED IS**
- \$26.00 — 3 years
 \$18.00 — 2 years
 \$10.00 — 1 year

Please allow six to eight weeks for delivery of first issue on new subscriptions

RONALD WYATT

Trinity Church
Galveston

Max Yount

beloit college, wis.
organ composition harpsichord choir

LAWRENCE

ROBINSON

VIRGINIA COMMONWEALTH UNIVERSITY
RICHMOND, VIRGINIA

Lynn ZEIGLER-DICKSON

Organist
Department of Music
IOWA STATE UNIVERSITY
Ames, Iowa

Gary Zwicky

DMA FAGO
Eastern Illinois University
Charleston

LYNNE DAVIS

International
Recitalist

FIRST PRIZE
ST. ALBANS
1975



10, rue Pierre et Marie Curie
92140 Clamart
FRANCE

DAVID GOODING

THE TEMPLE

CLEVELAND OHIO, 44106

LARRY PALMER

Professor of
Harpsichord and Organ

Director of
Graduate Studies in Music

Meadows School of the Arts
SOUTHERN METHODIST UNIVERSITY
Dallas, Texas

Musical Heritage Society recordings

CAROL TETI



Indiana University of Pennsylvania
Department of Music
Indiana, Pa. 15701

THOMAS MURRAY

RECITALS

1 Oak Street
Newburyport, MA 01950
(617) 465-5415

recordings on:
Nonesuch, AFKA,
Sheffield, Vista

JOHN HOLTZ

Faculty: HARTT SCHOOL, University of Hartford
Organist: CENTER CONGREGATIONAL CHURCH, Hartford

Ernest May

University of Massachusetts
Amherst, Mass. 01002
St. James' Episcopal Church
Greenfield

Calendar

(continued from p. 31)

27 APRIL
Paul Riedo, harpsichord; Meadows Museum, SMU, Dallas, TX 8:15 pm

1 MAY
Brad Kisner; St Andrews Episcopal, Stillwater, OK 8 pm
*Robert Glasgow; 1st Presbyterian, Seattle, WA 8 pm
Marilyn Mason; 1st Methodist, Palo Alto, CA 8:15 pm
Opera night; All Saints Church, Beverly Hills, CA 8 pm

3 MAY
Clyde Holloway, Schuller premiere; House of Hope Presbyterian, St Paul, MN 4 pm
Lynelle Williams, soprano; Good Shepherd Lutheran, Tulsa, OK 4 pm
Carlo Curley; Colorado School of Mines, Denver, CO 3 pm
James Hopkins; 1st Methodist, Pasadena, CA 3 pm
David Chamberlin; St Cross Episcopal, Hermosa Beach, CA 4 pm

6 MAY
Jack Ossewaarde; Christ Church Cathedral, New Orleans, LA 4 pm

8 MAY
Guy Bovet; St Marks Cathedral, Seattle, WA 8 pm
Robert Glasgow; 1st Congregational, Los Angeles, CA 8 pm

9 MAY
Beethoven Mass in C; High School, Glendale, CA 8 pm

10 MAY
Quentin Faulkner; St Barnabas Episcopal, Omaha, NE 4 pm
Milford Myhre, carillon; Univ of California, Riverside, CA 4 pm
Vocal Arts ensemble; 1st Congregational, Pasadena, CA 3 pm

11 MAY
*Competition winner; Highland Park Methodist, Dallas, TX 6:30 pm
*Organ recital; St Bede the Venerable, La Canada, CA 8:15 pm

12 MAY
Quentin Faulkner; Cathedral of the Risen Christ, Lincoln, NE 8 pm
*Clark Kelly; 1st Presbyterian, Tulsa, OK 8 pm

15 MAY
Charles S Brown; 1st Presbyterian, El Paso, TX 8 pm
*John Pagett, Dupré Stations; 1st Presbyterian, Santa Barbara, CA 8 pm

16 MAY
Charles S Brown workshop; 1st Presbyterian, El Paso, TX 10 am

17 MAY
Bach B-Minor Mass; St Lukes Episcopal, San Antonio, TX 4 pm
George & Barbara Klump, 2 organs; Presbyterian Church, La Crescenta, CA 4 pm

18 MAY
*Robert Glasgow masterclass; Sacred Heart Church, Duluth, MN 8 pm
Evensong; All Saints Church, Beverly Hills, CA 7:30 pm

19 MAY
*Robert Glasgow; Sacred Heart Church, Duluth, MN 8 pm

24 MAY
Baroque chamber music; St Matthews Episcopal, Portland, OR 8 pm

29 MAY
David Schralder; St Barnabas Episcopal, Omaha, NE 8 pm

31 MAY
Byrd, Durufle, Mozart Masses; All Saints Church, Beverly Hills, CA 5 pm
Baroque consortium; recital hall, Harbor College, CA 7:30 pm

INTERNATIONAL

16 APRIL
John Tuttle; St Pauls Church, Toronto, Ontario, Canada 12:10 pm

17 APRIL
Mozart C- Minor Mass; St Pauls Church, Toronto, Ontario, Canada 7:30 pm

19 APRIL
Lessons & Carols; St Johns Church, Toronto, Ontario, Canada 7:30 pm

23 APRIL
T Wollard Harris; St Pauls Church, Toronto, Ontario, Canada 12:10 pm

25 APRIL
Peter Collins; Town Hall, Rochdale, England 8 pm

26 APRIL
Gillian Weir; Park Church, Llanelli, Wales 8 pm

30 APRIL
Thomas Fitches; St Pauls Church, Toronto, Ontario, Canada 12:10 pm

2 MAY
William Bates; Martkirche, Wiesbaden, Germany 11:30 am
William Bates; Christuskirche, Schlangenbad, Germany 7:30 pm

3 MAY
Larry Cortner; Robertson-Wesley Church, Edmonton, Alberta, Canada 3 pm

7 MAY
Lorne Swan; St Pauls Church, Toronto, Ontario, Canada 12:10 pm

10 MAY
William Bates; Notre Dame Cathedral, Paris, France 5:45 pm

11 MAY
Jonathan Rennert; St Michaels Cornhill, London, England 1 pm

14 MAY
Don Thompson; St Pauls Church, Toronto, Ontario, Canada 12:10 pm

18 MAY
Roger Fisher; St Michaels Cornhill, London, England 1 pm

21 MAY
Tom Jones; St Pauls Church, Toronto, Ontario, Canada 12:10 pm

28 MAY
David Gibson; St Pauls Church, Toronto, Ontario, Canada 12:10 pm

MARILYN MASON

CHAIRMAN, DEPARTMENT OF ORGAN
UNIVERSITY OF MICHIGAN
ANN ARBOR

"Miss Mason played with austerity and reserve, demonstrating anew her extraordinary facility . . ." Des Moines Register, October 5, 1964

Gruenstein Award Sponsor

CHICAGO
CLUB OF
WOMEN
ORGANISTS

Kirstin Synnestvedt, D.M.A., President

Founded 1928

CLASSIFIED RATES

CLASSIFIED ADVERTISEMENT RATES
Regular classified advertising is single paragraph "want ad" style. First line one of each ad in bold face capital type.

Display classified advertisements are set entirely in bold face type with the first line in capital letters and the addition of a ruled box (border) surrounding the advertisement.

Regular Classified, per word\$.30
Regular Classified minimum 5.00
Display Classified, per word40
Display Classified minimum 15.00

Additional to above charges:
Box Service (mail forwarding) 2.50
Billing charge to non-established accounts (per insertion) 2.00

Closing Date (Classified): the tenth (10th) of the month for the next month's issue (Jan. 10th for the Feb. issue).

Non-subscribers wanting single copies of the issue in which their advertisement appears should include \$2.00 per issue desired with their payment.

The Diapason reserves the right to designate appropriate classification for advertisements, and to reject the insertion of advertising deemed inappropriate to this magazine.

POSITIONS AVAILABLE

TEACHING FELLOWSHIP AS ASSISTANT TO the University Organist for the academic year 1981-82, M.A. and Ph.D. programs in musicology, composition and ethnomusicology. Other assistantships requiring keyboard, theoretical and conducting skills also available. Deadline: 15 April 1981. For information, write Dr. Robert Sutherland Lord, 204 Music Building, University of Pittsburgh, Pittsburgh, PA 15260. The University of Pittsburgh is an equal opportunity, affirmative action employer.

FULL-TIME POSITION AVAILABLE AUGUST 1st: Minister of Music - Organist, Mt. Lebanon United Methodist Church, 3319 W. Liberty Av., Pittsburgh, PA 15216. Apply immediately by sending resume to Search Committee.

SEVERAL OPENINGS FOR ORGANBUILDERS with experience. Excellent wages and benefits, particularly for cabinetmakers and pipemakers. EOE/MF. Write or call: Visser-Rowland Associates, Inc., 2033 Johanna B, Houston, TX 77055. (713) 688-7346.

CHOIR DIRECTOR WANTED FOR 600-PLUS member church. Main concern to build choir program. For job description and salary schedule, apply: Search, First Presbyterian Church, 735 Orange Av., Ft. Pierce, FL 33450.

WANTED—PIPE ORGANS

USED PIPE ORGAN WANTED. SEND SPECIFICATION and price. Address C-5, THE DIAPASON.

HIGH PRESSURE PIPE RANKS AND PARTS to enlarge organ. Highest price for hard to find ranks, or will buy theatre organ, any condition. Address A-2, THE DIAPASON.

WANTED—MISCELLANEOUS

WE WILL PAY \$1.50 PER POUND FOR SPOTTED metal pipes or scrap delivered or shipped prepaid to our Gloucester workshop. Fair prices also for good common metal and tin. C. B. Fisk, Inc., Cape Ann Industrial Park, Box 28, Gloucester, MA 01930, (617) 283-1909.

NEED CHIME KEYBOARD (DEAGAN OR OTHER). 25 notes beginning G. Advise David McCain, days: (312) 298-6622, ext. 210.

WOOD 16' DIAPHONE, 12 OR 18 NOTES, preferably Wurliizer. No junk, please. Johnson Organ Company, Box 1228, Fargo, ND 58102. (701) 237-0177.

WANTED—MISCELLANEOUS

4' METAL GEDACKT OR 4' ROHRFLOTE, small or medium scale, low pressure (3-3 1/2" WP). P. Dettman, Box 560722, Kendall, FL 23156. (305) 666-0057.

ON 7 1/2" WP, ALL 8': E. M. SKINNER FRENCH Horn, English Horn, Echo Vox, Echo Flute Celeste, Echo Chimney Flute, Tuba 8' and/or 16' extension (possibly higher pressure). Also Chimes, Xylophone, Bass Drum/Tympani (from player organ). T. Borne, 204 N. Madison, Middletown, KY 40243.

MUSIC ROLLS FOR ANY PIPE ORGAN PLAYERS. Other rolls too. W. Edgerton, Box 88, Darien, CT 06820.

E. M. SKINNER TRUMPET AND FRENCH HORN on 7 1/2" wind pressure, also single rank E. M. Skinner chest. Write or call: Jim Brady, 1906 Broadripple Av., Indianapolis, IN 46220. (317) 259-4305 or (317) 849-1469 evenings.

MUSIC ROLLS FOR AEOLIAN DUO-ART, Welte and Skinner Automatic Pipe Organ Players. J. V. Maccartney, 406 Haverford Ave., Narberth, PA 19072.

MISCELLANEOUS

FOR SALE: ORGANBUILDING AND SERVICE business in East. Excellent staff and reputation in both electrical and mechanical instruments. Present owner and tech director willing to remain. Principals only. Address H-5, THE DIAPASON.

LEARN ORGAN VOICING AT HOME. UP-TO-DATE voicing manual and basic 600-piece tool kit includes many items never before offered. Learn the closely guarded secrets of master voicers. Supplies include 2-lb can vacuum-packed chuff, jar of chuff solvent, complete ictus scale that includes markings for Audsley, Schnitger and Dom Bedos tremulant beats, chrome-plated vernier nicking pliers in both English and metric measure, pressure gauge especially calibrated in Gauss (up to 10,000!) and many other items too numerous to mention. Free complete catalog and tuning fork in peds du roi with pre-paid orders. Address UR12, THE DIAPASON.

THE NEW 7-OCTAVE PETERSON CHROMATIC Tuner model 320, is now available from stock. Continuously variable Vernier control allows you to compensate for temperature or tune celeste ranks with ease. For more details: Peterson Electro Musical Products, Dept. 31, Worth, IL 60482.

ORGANIZATIONS

ATTENTION ILLINOIS, INDIANA, MICHIGAN and Wisconsin residents: There is now a chapter of the Organ Historical Society serving your area. If you share an interest with us in extant vintage organs, and outstanding examples of the organ builders art and skill of more recent periods you'll want to write for membership details. Thomas A. Burrows, Chicago, Midwest OHS, 1621-B Salisbury Ct., Wheaton, IL 60187.

PUBLICATIONS & RECORDINGS

CATALOGUE "N", 1,000+ BOOKS AND RECORDINGS. \$1.00 (refundable with first order). The Organ Literature Foundation, Braintree, MA 02184.

SINGLE VOLUME, FIRST EDITION, AUDSLEY, "The Art of Organbuilding". Reasonable offers considered. Address M-4, THE DIAPASON.

A COMPLETE LISTING OF ALL AVAILABLE back-numbers of THE DIAPASON is now available. Many from the 1930's on, and some older issues may also be obtained for your personal or library collection. Send SASE to The Organ Historical Society, Box 209, Wilmington, OH 45177.

VIRTUOSO PERFORMANCES RECORDED ON Welte Organ Rolls in Germany. Re-performed on a 1929 Welte-Tripp organ. Featured at 1976 AGO convention, now available in stereo. Includes many 19th century favorites; Poet and Peasant Overture, Lemmens Storm, Dance Macabre, etc. Played by Farnam, Gigout, Eddy, Goss-Custard and E. H. Lemare. Two Dolby stereo cassettes \$15 postpaid in U.S. Welte Recordings, 292 Shawmut Av., Boston, MA 02118.

TUNING TABLES FOR HISTORIC TEMPER-aments. Beat rates for fifths and thirds. 45 tables brief introduction, \$4.50 pp. Rodney Myrvaagnes, Harpsichord Maker, 50 Columbia St., Newark, NJ 07102.

LATIN GREGORIAN CHANT, ENGLISH translation of introduction, rubrics, and general index of 1974 Graduale Romanum (Solesmes edition) or 1975 Graduale Simplex (Vatican edition). \$3.50 each. Both for only \$4.95. A must for anyone interested in using chant in the revised Roman Catholic Mass. Useful glossary included free with each order. Send check or money order to: Christopher M. Schaefer, 35 Washington Av., Seymour, CT 06483.

Shawhan Pipe Organs
REBUILDING — SERVICE
— NEW ORGANS —
1901 Howell Street
Fort Wayne, Ind. 46808
219-422-8863

TRACKER-TOOL ORGANS

330 NORTH A ST., LOMPOC, CA.
93436

VISSER-ROWLAND
713/688-7346
2033 JOHANNA B
HOUSTON 77055
Member
International Society of Organbuilders
Associated Pipe Organ Builders of
America

W. J. Walcker
Organ Builders
1780 — 200 Years — 1980
Tradition and Progress
D-7157 Murrhardt-Hausen 10
Phone 07192/8006

Kimber-Allen, Inc.
Box 4058, C.R.S.
Johnson City, TN 37601
615-282-4473
Quality Organ Components

REPAIRING TUNING ADDITIONS
R. W. KURTZ ORGAN CO.
CONSULTANT SPECIALISTS ON PIPE ORGAN REBUILDING
P. O. Box 32, Woodstown, N. J. 08098 • 609 / 769-2883

FINE ORGAN LEATHERS SINCE 1800
BEVINGTONS AND SONS of LONDON
THROUGH OUR U. S. of A. AGENTS
COLKIT MFG. COMPANY
252 FILLMORE AVE.
TONAWANDA, N.Y. 14150

ORGAN SUPPLY INDUSTRIES
INCORPORATED
645 WEST 32ND STREET • P. O. BOX 1165 • ERIE, PA. 16512
QUALITY PIPE ORGAN SUPPLIES

TRACKER-TOOL SUPPLY CO.
tools and supplies
For ORGAN BUILDERS

799 West Water Street, Taunton, Massachusetts 02780

Harris Organs Pipe Organ Builders
7047 South Comstock Avenue, Whittier, California 90602 • (213) 693-4534
Robert M. Turner, Tonal Director • Member: International Society of Organ Builders, American Institute of Organ Builders • Inquiries are cordially invited.

CLASSIFIED ADVERTISEMENTS

Classified advertising rates will be found on page 33.

Replies to box numbers should be sent c/o The Diapason, 380 Northwest Highway, Des Plaines, IL 60016.

HARPSICHORDS

FLOWER YOUR HARPSICHORD SOUNDBOARD with authentic decorations. Ruckers-type birds, bees, flowers, \$35. Early 18th C. French, \$40. Full-size layout and complete instruction manual. Shirley Mathews, Box 401, South Street, Freeport, ME 04032.

CLEARING HOUSE: NATIONAL LISTING OF instruments currently available for sale. Send SASE, please. Glenn Giuttari, 9 Chestnut St., Rehoboth, MA 02769.

1979 KEITH HILL HARPSICHORD, SINGLE, 2x8', excellent condition. Contact: Karen Reger, N47 W27515, Hwy. JK, Pewaukee, WI 53072. (414) 691-3692.

HARPSICHORDS, PEDAL HARPSICHORDS, clavichords custom made. Jan H. Albarda, 14 Princess St., Elora, Ont., Canada N0B 1S0.

HARPSICHORDS, CLAVICHORDS, FORTEPIANOS, Custom instruments and kits. Write for free brochure. Zuckermann Harpsichords Inc., Box 121-D, Stonington, CT 06378.

HARPSICHORDS, CABINET ORGANS, PORTA-tive Organs, Clavichords. We make historically derived instruments to your specification. For further information, please write: Paul F. Martin, Organs and Harpsichords, 680 King Street West, Toronto, Ontario, Canada, M5V 1N3.

ITALIAN VIRGINIAL IV, BUILT FROM ZUCKER-mann kit, antique red with bench, 3 years old. \$1500. R. I. Ufkes, 8401 Dempster, Niles, IL 60648.

ITALIAN PENTAGONAL SPINETs, ENGLISH Bentside Spinets, Virginals and Harpsichords custom designed, voiced and regulated in classic manner. Call or write: David J. Holmes, Luthier, 123 Cathedral St., Annapolis, MD 21401. (301) 268-0523.

HARPSICHORD, DOUBLE MANUAL AFTER Dulcken. Includes nasale and buff stops, with range FF to g'. Beautiful mahogany veneer, \$6000. Jean Nandi, 2119 Los Angeles Av., Berkeley, CA 94707. (415) 526-3525.

HARPSICHORD AND ORGAN PLANS. SEND \$3 for illustrated catalog to: R. K. Lee, 353D School Street, Watertown, MA 02172.

SPERRHAKE CLAVICHORD, USED MODEL "Hubert" in very good condition. Five octaves. Also, latest catalogs pertaining to Sabathil harpsichords. New Flemish single harpsichord based on 1640 Ruckers available soon. Write: John W. Allen, 500 Glenway Av., Bristol, VA 24201.

HARPSICHORD TUNER. SET ANY TEMPERA-ment automatically with the AccuTone tuner: Equal, Mean Tone, Kimberger, Werkmeister, etc. Carl Dudash Harpsichords, 11 Jewel St., Enfield, CT 06082. (203) 749-6800.

IF YOU PLAN TO BUY A HARPSICHORD THIS year, let me help you select exactly the right one from our wide selection of singles, doubles, virginals and spinets. Clavichords and fortepianos also available. Save with a Zuckermann kit, or let me finish one to your specifications. Professional work always. Authentic action and tone. Free catalog from: R. D. Ludden Harpsichords, 1002 Leroy Av., Rock Falls, IL 61071.

HARPSICHORDS

ATTENTION: POTENTIAL HARPSICHORD BUY-ers. If offered a Neupert Christifori model #23692, rosewood, on casters, contact music department, Los Angeles Valley College, 5800 Fulton, Van Nuys, CA 91401, or call (213) 781-1200, ext. 347.

HARPSICHORDS, CLAVICHORDS, SPINETs, fortepianos as semi-kits and fully finished instruments. Send 50¢ for brochure. Or start from scratch. \$1 for catalog of parts. Plans. The Instrument Workshop, 318 N. 36, Seattle, WA 98103.

HARPSICHORDS, CLAVICHORDS BY NEUPERT, world's finest, oldest maker. Catalogs on request. Magnamusic, Sharon, CT 06069.

YVES A. FEDER HARPSICHORD MAKER, PRO-fessional workshop devoted to clavichords and harpsichords. Custom Made, finished, voiced and regulated. Also authorized agent for full line Zuckermann historically derived kits at reasonable prices. Advice and trouble-shooting for kit builders. North Chestnut Hill, Killingworth, CT 06417.

SPERRHAKE HARPSICHORDS AND CLAVI-chords. Excellent, dependable, beautiful. Robert S. Taylor, 8710 Garfield St., Bethesda, MD 20034.

HARPSICHORD OWNERS. A FULL LINE OF audio and visual Chromatic Tuners is now available to help you with your tuning requirements. For more information write Peterson Electro-Music Products, Dept. 20, Worth, IL 60482.

BURTON HARPSICHORDS, SPINETs, AND clavichords—Professional instruments in kit form, from \$195. For brochure write Burton Harpsichords, 727 "R" St., P.O. Box 80222D, Lincoln, NE 68501.

FORTEPIANO

JUST ARRIVED! SOFT IRON WIRE SPECIALLY drawn for short-scaled fortepianos. Stein fortepiano restringing kit or available in individual ranks. For further information or instrument replica brochures, write: Philip Belt, America's most experienced Forte-piano Maker, 26 Stanton St., Pawcatuck, CT 06379.

FOR SALE—PIPE ORGANS

CLASSICAL 2 MANUAL, 5-RANK PIPE ORGAN, Wicks chests. Good condition. Sell or trade for Theater organ. Address A-4, THE DIAPASON.

NEW 1-MANUAL AND PEDAL SELF-CONTAIN-ed tracker action pipe organ. 3 registers, classic voicing, Holzgedackt 8', Rohrflote 4', Prinzipal 2'. 56 note manual in ebony and white beech, divided for bass and treble. 30 note attached pedal. Drawknobs in rosewood, 3 each bass and treble. Contemporary oak encasement, \$15,000. F.O.B. Ruhland Organ Company, 7715 Marlborough Avenue, Cleveland, OH 44129.

SMALL UNIT ORGAN, 2-MANUAL, 4-RANKs, 20 stops, encased pipework, detached console. Available late fall. Write: Box 2061, Knoxville, TN 37901.

14-RANK GREAT, POSITIV, PEDAL PIPE OR-gan, slider chests, built 1965, \$18,000. Offers. Send SASE for specifications: Rive, Inc., 811 Focis Street, Metairie, LA 70005.

FOR SALE—PIPE ORGANS

NEW 2-MANUAL UNIT ORGAN, 20 STOPS, 4 ranks, 32-note pedal, encased pipework, separate console. Write: Lee Organs, Box 2061, Knoxville, TN 37901.

PIPE ORGAN, 15-RANKs, CURRENTLY IN USE. Purchaser to remove in late June 1981. Best written offer over \$3,000. St. Timothy United Methodist Church, 5365 Memorial Dr., Stone Mountain, GA 30083. (404) 292-5969.

1 MANUAL AND PEDAL, 2-RANK TRACKER cabinet, portable organ. Many options possible by original builder. Oak case and many extras. For details and photograph, send \$1.00 in stamps. Address C-3, THE DIAPASON.

PIPE ORGAN, KILGEN (1936), 3 MANUALs, 18 ranks, 32 stops; 16' pedal Open Diapason, 5 reeds, chimes. Offered by sealed bid, available for inspection April 1, 1981; buyer responsible for removal. Bid documents, complete specifications and condition available upon request. Bids open June 15, 1981. To arrange for inspection contact U. A. Eberhart, Director, Business Services and Contracts, Central Washington University, Ellensburg, WA 98926. (509) 963-2324.

SCHLICKER, 2-MANUAL AND PEDAL, 15 stops. Organ like new, suitable for home, chapel or small church. \$17,500. H. Stouffer, Rt 79, Box 180-C, Houghton Lake, MI 48629. (517) 366-9238.

CHURCH PIPE ORGAN. TWO MANUAL AND pedal Wangerin, ca. 1925, 18 ranks. 8 new ranks added 1966. For further information write: Grace Lutheran Church, P.O. Box 756, Green Bay, WI 54305.

3-MANUAL, 28-RANK REUTER (C. 1940), NOW in use. Buyer to remove. Best offer. Contact Ron Pearson, 709 S. Boston Av., Tulsa, OK 74119. (918) 584-4701 or 587-7941.

FULL 9-RANK TRACKER PIPE ORGAN, COM-pletely renovated, available immediately. Address: Attn: Edgar N. Peppler, Masonic Charity Foundation of NJ, Development Office, P.O. Box 308, Burlington, NJ 08016.

1929 HILLGREEN & LANE PIPE ORGAN, eleven stops, plus chimes. All bids are to be submitted by June 1, 1981, subject to approval by church. First Baptist Church, Box 230, Wharton, TX 77488.

8-RANK ESTEY PIPE ORGAN, HASKELL PIPES. New console and action. \$6,500. Skinner French Horn and chest: Celeste, 49 notes. Austin Vox Humana. B. Stark, Grandville, OH. (614) 587-0319.

NOEL MANDER OFFERS MEDIEVAL PORTA-tives, £825. Two fine early nineteenth century chamber organ, £6000 and £9000 and one by Green, about 1770, £10,000. All ex. works. Those interested, please send five dollar bill, Noel Mander, St. Peter's Organ Works, London E2, England.

WICKS 2-MANUAL, 4 1/2-RANK, IN FAIR CON-dition. Presently in storage. Digipipe, 2306 April Lane, Grand Prairie, TX 75050. (214) 647-2031.

ORGAN, 1960 3-MANUAL CONSOLE, 22 ranks, original Austin pipes, 1920's. Best bid by June 15. Presently in use. Emmanuel United Methodist Church, 75 East Avenue, Lockport, NY 14094.

FOR SALE—PIPE ORGANS

HOOK & HASTINGS, 2-MANUAL, 7-RANK, tubular-pneumatic, Circa 1900. Buyer to remove. Best offer considered. Call (617) 734-5553.

2-MANUAL REUTER PIPE ORGAN, 5 STOPS, excellent condition, circa 1930, \$14,000. For information write: Charles M. Fiser, 3663 S. Sheridan, H-9, Denver, CO 90235.

E. M. SKINNER, 1917, 4 MANUALs, 90 STOPS, much original pipework, some new ranks. Available May 1981 for best offer over \$25,000. Buyer to remove Summer 1981. SASE for details to: First United Church, 848 Lake St., Oak Park, IL 60301.

HALL PIPE ORGAN, ELECTRO-MECHANICAL, late 1800's vintage. All hand-crafted, Exterior in good condition. Excellent mechanism. Complete unit. Needs minor adjustments and repairs. All reasonable offers will be considered. Address all inquiries to Dr. J. H. Jones, Kingdom of God at Hand Church, Box 1887, Paterson, NJ 07509. (201) 345-9441.

1929 MOSTLY MOLLER (4-MANUAL SKIN-ner console and some Skinner pipework) in Harrisburg, PA. 30 ranks, majority in good condition. Contains high pressure solo: Tuba Mirabilis, French Horn, Stentorphone, etc. Accepting offers for whole organ until May 30, 1981. Reservations for individual parts accepted in case of unacceptable bulk bids. June removal. Send SASE for specifications to: Harold Ulmer, 244 South Sixth Street, Lebanon, PA 17042.

THEATRE ORGANS

3-MANUAL, 12-RANK THEATRE PIPE ORGAN. Includes Solo Tibia, Vox, Flute, Diapason, Viol and Celeste, Solo String, Clarinet, Tuba Trumpet, English Post Horn, Kinura, Four ranks to 16'. Xylophone, Glock, Chrysogloff, Chimes, Marimba and Piano. Complete trap section, 5-hp, 15" Spencer 3-phase, 220V blower. Just removed, ready and available for inspection. Asking \$24,000 or nearest offer. Crating, shipping and installation available. For details, write: C. J. Newman, 901 W. Lake Street, Minneapolis, MN 55408. (612) 781-9205, or evenings (612) 545-6061.

BEST OFFER GETS THIS 2-MANUAL, 6-RANK Barton with single phase blower and more. For further information, contact: Ron Willfong, 3005 Pioneer, Oklahoma City, OK 73107. (405) 943-1980.

21-RANK WURLITZER/KIMBALL/MORTON HY-brid theatre pipe organ, 90% re-leathered. 5 16's including Kimball Harmonic Tuba, 15" WP. 6 ranks of amazing strings with Kimball V.D.O. and celeste, Lush Morton Tibia and Vox, 3-rank Mixture, Four-tuned percussions and toy box. 15-hp blower, \$21,000. Dave Gentry, 3013 Rocky Point Road, Bremerton, WA 98310. (206) 377-3640 or 858-6131 ext. 306.

REED ORGANS

TWO MANUAL AND PEDAL (30-NOTES) MA-son and Hamlin reed organ, with separate blower. \$1,000 or good offer. Johnson Organ Co., Box 1228, Fargo, ND 58107. (701) 237-0477.

KIEFER TANNING CO.

240 FRONT • GRAND RAPIDS, MI. 49504
(616) 459-3401
IMPORTED AND DOMESTIC LEATHER

M. F. Benzene & Co.

Additions—Rebuilding
Tuning—Repairs
35 Bethpage Road
Hicksville, L.I., NY 11801
516-681-1220

SCHNEIDER ORGELBAU WERKSTATT, Inc.

New Instruments — Rebuilding
Tonal Alterations — Revoicing
Revoiced Classic Pipework —
Organ Maintenance
Workshops in Niantic & Kenney, Illinois
P.O. Box 382 Niantic, IL 62551
(217) 668-2412 944-2454

TUNING EMERGENCY SERVICE

A. McNEELY & COMPANY

CHURCH PIPE ORGAN TECHNICIANS
22 JORDAN COVE ROAD
WATERFORD, CONNECTICUT. 06385

PROFESSIONAL MAINTENANCE TEL. 1-208-448-8208

Robert Copeland

10134 BUCHANAN ROAD
PITTSBURGH, PA. 15235
242-8288

 Pipe Organ Repair - All Makes

Klug & Schumacher

PIPE ORGAN CRAFTSMEN
3604 Waterfield Parkway
Lakeland, FL 33801 • [813] 665-4802
Mechanical Organs

CYMBELSTERNs

are available again . . .

GEISLER & COMPANY
3629 Lynndale Place
Fort Worth, TX 76133

Organ advice from EDWIN D. NORTHRUP

B.A., JUR. D.
2475 LEE BOULEVARD
CLEVELAND, OHIO 44118
TEL. (216) 932-4712

RAYMOND GARNER ASSOCIATES

Pipe Organ Builders and Craftsmen
P.O. Box 4478 Telephone
Crestline, CA 92325 (714) 338-3751

revoicing — tonal improvement
rebuilding — service — additions

DURHAM

Tallahassee, Florida
32304
P.O. Box 2125 — (904) 575-2001

DEAGAN

Chime Co.
2023 Eastern Ave.
Cincinnati, O. 45202
(513) 221-8600

Sherwood Organ Company Inc.

85 Longdale Avenue
White Plains, New York 10607
(914) 946-7990 (212) 582-4240
Service — Mechanical and Tonal Rebuilding — New Organs



CREATIVE ORGAN BUILDING FOR ARTISTIC MUSICAL RESULTS

Greenwood Organ Company

P. O. BOX 18254, CHARLOTTE, N.C. 28218
"THREE GENERATIONS OF ORGAN BUILDING"

REED ORGANS

2-MANUAL AND PEDAL, 10-RANK ESTEY REED ORGAN (1923). Complete with false pipe top. Oak case. Excellent condition. L. D. Porter, 325 Creston Av., Kalamazoo, MI 49001. Phone after 5 p.m. or weekends: (616) 381-6426.

ESTEY 2-MANUAL AND PEDAL REED ORGAN. 5 sets of reeds. Dark stained oak. Fully rebuilt. \$1200. Buyer to remove. J. Fitzer, 144-07 Holly Av., Flushing, NY 11355. (212) 886-5040.

REPLACEMENT REEDS AVAILABLE FOR USE in parlour reed organs. Send inquiry to: Paul W. Toelken, Box 5017, Prescott Valley, AZ 86312.

REED ORGANS RECONDITIONED, FOR SALE. Specializing in two-manual with pedal instruments. Send stamped business envelope for catalog. Ned Phoenix Reed Organ Service. Box 3, Jamaica, VT 05343.

ESTEY REED ORGAN, ELECTRIFIED. 32 PEDALS. Tracker, similar to pipe organ. \$400. Alex Sankoly, 4712 Broadale, Cleveland, OH 44109.

ENGLISH HARMONIUM, CIRCA 1800, FIVE octave, double bellows, brass reeds pressure activated. Oak case. Bellows, feeders, reservoir rebuilt 1979. \$300 or best offer. Laura Richardson, 405 Auburn St., Cranston, RI 02910. (401) 461-0447.

REED ORGAN REPAIRING — REEDS RE-tongued. John White, 2416 Irving South, Minneapolis, MN 55405. (612) 377-1950.

FOR SALE—ELECTRONIC ORGANS

ALLEN, CONN CHURCH, THEATRE ORGANS. 350 grand pianos. Largest selection in USA over 1500. Victor, 300 N.W. 54th St., Miami, FL 33127. (305) 751-7502.

CUSTOM BUILT ELECTRONIC ORGAN with impressive 3-manual drawknob console. 8 generators provide 63 speaking stops dispersed through 24 independent channels of amplification. Great and Swell divisions have 16' manual stops. One celeste stop on Choir and three celeste stops on Swell. Mixtures, reeds and complete principal choruses on each manual and in pedal. Pedal has two 32' stops. All speaking stops and couplers are controlled by over 90 drawknobs. Capture-type combination action for 40 pistons. 17 toe studs duplicate general and pedal combination pistons and reversible actions. Church will consider reasonable offers. For details please contact: The Reverend John W. Thomas, Rector, St. John the Evangelist Episcopal Church, 226 W. Lexington Av., Elkhart, IN 46514. (219) 295-1725.

RODGERS 34-A CLASSICAL ORGAN, 2 MAIN, 1 pedal and 2 antiphonal tone cabinets. 32 foot extension. Capture combination action. \$19,500. Address D-2, THE DIAPASON.

ALLEN ORGAN, MODEL TC-4, AGO CONSOLE, external speakers, good condition. Available May 1, 1981. 9:00 to 3:00, (614) 267-4991.

FOR SALE—ELECTRONIC ORGANS

ALLEN THEATRE ORGAN DELUXE, AGO specifications, 2 full manuals, 32 pedals, combination action, 3 tone cabinets, \$3500. (904) 672-7500.

1977 CONN ARTIST, 2 MANUALS, FULL PEDAL, 2 sets of electronic pipes, 28 stops including mixtures. Standard couplers and combination pistons. Excellent condition. Suitable for small church or residence. \$8500, negotiable. Contact: L. L. Goulder, P.O. Box 636, Attleboro, MA 02703. (617) 222-8500.

FOR SALE—MISCELLANEOUS

HAVE YOU A RELATIVE OR A FRIEND WHOM you think might like to see a copy of THE DIAPASON? If you have, send name and address to THE DIAPASON, Dept. C, 380 Northwest Highway, Des Plaines, IL 60016. A complimentary copy will be sent by return post.

2000 RARE DECO PIANOS AND ORGANS. 400 grands and church organs. Victor's 300 NW 54th St., Miami, FL 33127. (305) 751-7502.

ADJUSTABLE SUCTION/BLOWER UNITS FOR reed organs, players, 1-3 rank pipe organs, \$85.00. C. Durham, P.O. Box 2125, Tallahassee, FL 32304.

4-MANUAL AUSTIN DRAWKNOB CONSOLE, rebuilt '70's, \$2,750. 16' large scale Moller pedal Bourdon pipes, wood, 56 note compass, 7-note bass chest, \$520. 16' large scale Moller pedal Bourdon pipes, 44, metal, \$450. Other consoles: Moller, Austin, Kimball, Gottfried, Reisner, Klann, 2, 3, 4-manuals. Must sell. Rive, Inc., 811 Focis St., Metairie, LA 70005.

16' LIEBLICH GEDECKT WITH CHEST; SEVERAL sets of Dulcianas, Gambas and Vox Humanas; Offset chests of all sizes; Two manual console, complete; Reisner gang switches; Large cone-valve reservoir; rectifiers; shade action for individual shades; manual slides and low pressure blowers. Send SASE for list to: Johnson Organ Company, Box 1228, Fargo, ND 58107. (701) 237-0477.

WAREHOUSE CLEARANCE SALE: LARGEST inventory of pipes and various other components, some new, some old. Various makes. Send SASE for list. W. J. Froehlich, 446 Grove St., Westfield, NJ 07090.

USED PIPES, CHESTS, CONSOLES AND MISCELLANEOUS equipment in good condition. Write: Box 2061, Knoxville, TN 37901.

4-STOP KILGEN (NOT PETITE ENSEMBLE), 2 6-stop Kilgen chests, 4 and 5-stop Estey chests, Misc. chests, many used pipes, lots of zinc basses, nameboards with tripper action, low prices! Gibson Organs, Inc. (501) 664-4363 or 661-9460.

ORGAN PARTS FOR SALE: CHESTS, CONSOLES, reservoirs, pipework, and many miscellaneous components. Send SASE with your inquiry stating your specific needs. Sorry, no list. Sold as-is, or rebuilt to our requirements. Address C-2, THE DIAPASON.

FOR SALE—MISCELLANEOUS

CONSOLES: WAREHOUSE CLEANOUT. CASH and carry. 3-manual Reuter drawknob, oak, late '40's, \$750. 3-manual Moller, drawknob, oak, 1958, \$4200. 3-manual Klann, stop tab, mahogany, 1965, \$3500. 3-manual Tellers, stop tab, oak, \$500. 2-manual Moller, oak, 1958, \$500. 2-manual Klann, oak, 1962, \$2500. 2-manual Klann, oak, 1965, \$2500. Fritsche Organ Company. (215) 797-2510.

1928 AUSTIN DIAPASON RANKS: MAJOR Open, English, Horn. \$150 each, First Presbyterian Church, 406 Grant St., Wausau, WI 54401. (715) 842-2116.

TIRED OF CHIFFY, CLICKING, CLACKING ill-voiced pipes? Tired of too much transient attack noise in your beautiful Schnappwerk chorus? Or, maybe you're tired of that dull, listless string which instead of being Dulciana is just Dull. Either way, our modern scientifically-designed patent-pending pipes can solve this problem. Too much attack or not enough attack can now be things of the past! The solution is so simple you'll chuff a bit yourself for not having thought of it first!! Our revolutionary pipes solve the problem of poor voicing (or poor voicers) by eliminating the actual root of the problem!!! That is correct—we are now marketing pipes without lips!!! The sound of the pipe simply exits through a small Angelic Opening (patent pending) and bypasses all that nonsense of lips. By replacing all the old-fashioned labial pipes in your current organ, you can finally produce the sound of the Heavenly Jerusalem. Lippless Pipes, c/o THE DIAPASON.

RANKS OF PIPES, CHESTS, BLOWERS AND parts. Send SASE for recent list. The McNeely Organ Company, 24 Jordan Cove Rd., Waterford, CT 06385.

2 WURLITZER 2-MANUAL, 7-RANK RELAYS. Any reasonable offer accepted. (312) 968-5034.

IVORY KEYBOARDS, 4 SETS, UNUSED, 6-NOTE. Philip Klann, Klann Organ Supply, (703) 949-8737.

THREE WOODEN KEYBOARDS, INCLUDING their coupler slide mechanisms (all matching and in good condition). Already wired and ready for installation in either a pipe or electronic organ. Contact: Brad Anderson, 30516 Fairfax, Southfield, MI 48076, or call (313) 646-0143.

WURLITZER SHADES AND ACTION, 95" x 77", \$60; Morton shades and action, 82" x 86", \$50; 14" x 22" regulator, \$20; 4' Principal, Twelfth, Fifteenth, Tierce, 8' Melodia and matching 4' Flute Celeste, 4' Dulciana & Celeste, 4' Octave, all 61 notes, 5" WP, \$75 per rank. All prices excluding crating or shipping. Organ Parts, 1001 Bjork Drive, New Lenox, IL 60451.

3-MANUAL HORSESHOE CONSOLE (ARTISAN Imperial), pedalboard, manuals, bench, for pipe or electronic organ. Comparable to Devtronix, over \$3500, \$1750. Ned Siebert, 1221 Jackson St., Jasper, IN 47546.

FOR SALE—MISCELLANEOUS

4-MANUAL AUSTIN CONSOLE, 109 STOP KEYS, partially restored, \$1000. Wangerin harp, 49 notes, \$600. Wangerin chimes, 25 notes, \$200. Organ Supply 16' wood trombone, 73 pipes, 7" wind, \$1000. Austin 16' Tuba, 7 1/2" scale, 6" wind, 73 pipes, \$1000. 4' gemshorn, 49 pipes, \$150. Baranger Studios, 729 Mission, South Pasadena, CA 91030.

3-MANUAL CONSOLE, FULLY EQUIPPED, \$625. Unit chest, \$95. 3'-WP Dolce, \$110, Voix Celeste, \$90. (301) 434-0833.

VOIX HUMANA, SPOTTED METAL, \$450; VOIX Humana, common metal, \$350; 4' Oboe, \$350; 4' Open Wood Flute, \$300; 4' Flute d'Amour, \$300; 8' Rohr Flute, 85 pipes, \$350; 2' Flautino, \$300; 1-3/5' Tierce, \$300. All pipes cleaned and revoiced, 3/4" wp, 440 pitch. Knicking removed from all wood pipes. Also: Volumes 1 and 2, "The Art of Organ Building", by Audsley. Original, not reprints, \$95. Conrad O. Olson, 221 Adams Street, Waltham, MA 02154. (617) 894-4850.

SERVICES & SUPPLIES

RELEATHERING: ALL TYPES POUCHBOARDS, regulators, etc. Best quality leather. Will remove and reinstall. Herndon Organ Company, Toledo, OH 43691. Call collect: (419) 241-8822.

NEW ORGAN PIPES MADE TO YOUR SPECIFICATIONS. 25 years experience. James Morris Organ Pipe Company, 4476 State Road, Cleveland, OH 44109.

USED REVOICED CLASSIC PIPEWORK. VARIOUS registers offered for one-half price of new pipework. We will also revoice your romantic pipes on a time and materials basis. Contact: Schneider Orgelbau, Box 382, Niantic, IL 62551. (217) 668-2412.

AUSTIN CONSOLES OF ANY SIZE OR VIN- tage bought, sold, or modified by factory trained technician. Auchincloss Service, P.O. Box 5262, Poughkeepsie, NY 12602. (914) 236-7154.

ORGAN SERVICEMEN: WE WILL RECOVER Casavant and Skinner pouchboards, primary and offset actions. Write: Burness Associates, P.O. Box 344, Glenside, PA 19038.

TUNERS! THROW AWAY MESSY COTTON. Use all felt K D Kaps — the best aid for frustrating mixture tuning. Set of seven, \$10. K D Kaps, P.O. Box 223, Bolton, CT 06040.

RECOVERING ANY TYPE OF POUCHES, PNEU- matics and primaries in leather. Reservoirs re-leathered also. Write: Eric Brugger Releathering Service, 1034 East 29th St., Erie, PA 16504.

NEW ORGAN PIPES, EXCELLENT WORKMAN- ship and expertly voiced. Formerly supervisor of Aeolian-Skinner pipeshop. Hans Rother, German Organ Pipecraft, 34 Ständard St., Mattapan, MA 02126.

JULIAN E. BULLEY

New Organs — Rebuilding Service
SINCE 1906

1376 Harvard Blvd.—Dayton, Ohio 45406
513-276-2481

DO IT YOURSELF PIPE ORGAN KITS

Custom specifications for church or residence, complete or parts, full instructions by established organ builders.

COLKIT MFG. CO.

252 Fillmore Ave., Tonawanda, N.Y. 14150

WANT A PRACTICE ORGAN?

PEMBROKE PIPE ORGAN (in kit form)

Send stamp for brochure

THE ORGAN LOFT

EPSOM, N.H. 03234 Tel. 603-736-4716

Remember: If it does NOT have pipes, it is NOT an organ

BERKSHIRE ORGAN COMPANY INC.

68 SO. BOULEVARD, WEST SPRINGFIELD, MASSACHUSETTS
Area Code 413-734-3311, 736-1079

Member: American Institute of Organbuilders
International Society of Organbuilders



Stephan Schumacher

4700 EUPEN / Belgium

Peculiar

Mechanical Organ Parts

ELECTRIC EXPRESSIVE PERCUSSIONS

For Pipe or Electronic Organs

Operates from under key contacts. Full concert instruments, marimbas, vibraharp, orchestral bells, xylophones, and pianos, in 2' and 4' stops. Only manufacturer of such instruments in USA.

Call collect (217-422-3247) for order acceptance or write

dii **DECATUR**
INSTRUMENTS
INCORPORATED

Decatur Instruments, 1014 E. Olive Street, Decatur, Illinois 62526.

Murtagh-McFarlane Artists, Inc.

127 Fairmount Avenue

Hackensack, New Jersey 07601

201-342-7507



Marie-Claire Alain



George Baker



Robert Baker

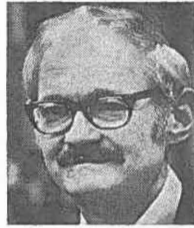

David Craighead



Catharine Crozier



Gerre Hancock



Judith Hancock



Clyde Holloway



Peter Hurford



Marilyn Keiser



Joan Lippincott



Marilyn Mason



James Moeser



Martin Neary



Simon Preston



George Ritchie



Donald Sutherland



Frederick Swann



Ladd Thomas



John Weaver

European Artists Season 1981-82

October-May



Guy Bovet

February



Susan Landale

November
(limited)



Peter Planyavsky

November



Daniel Roth

DUO RECITALS

Phyllis Bryn-Julson, soprano — Donald Sutherland, organ

Marianne Weaver, flute — John Weaver, organ

Pierre D'Archambeau, violin — Marilyn Mason, organ/harpsichord