

# THE DIAPASON

SEPTEMBER 1983

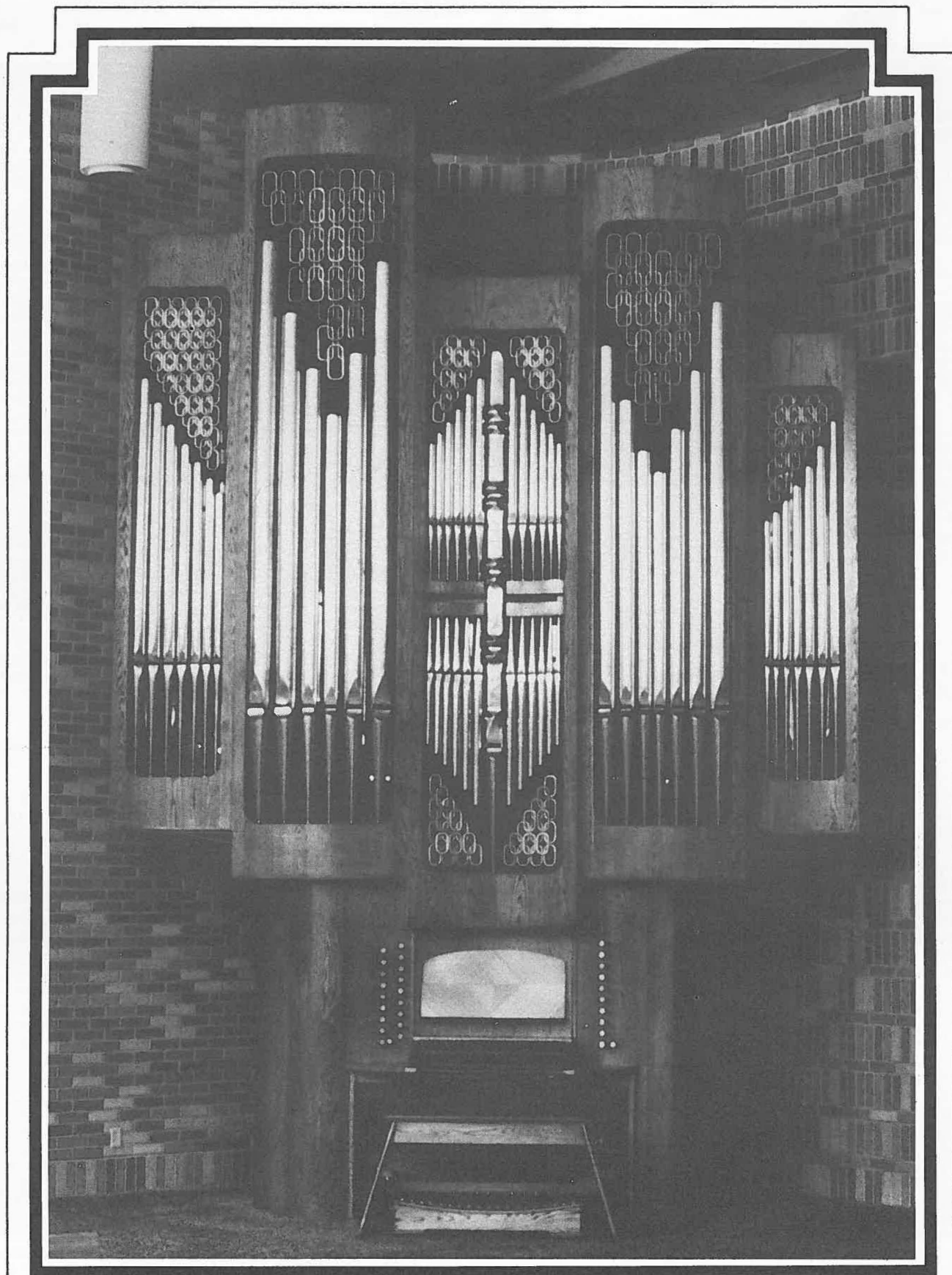

Immanuel Lutheran Church, Valparaiso, Indiana  
Specification on page 22

## Editorial

We question why Joseph Fitzer, writing for the AGO Committee on Professional Concerns in the July, 1983 issue of *The American Organist* ("Why Didn't We Do This Before?"), would choose to refer to our editorial of July, 1982 ("Another Look at Professional Concerns") as being "a well-meaning but uninformed suggestion," but then continue to demonstrate that his disagreement was not so much with what we said, but rather what he *thought* we said. We would suggest that Mr. Fitzer would do well to obtain a copy of Mortimer Adler's new book, *How to Speak; How to Listen*.

Our editorial suggested that the Guild would better achieve its goals for professional conditions through denominational channels, as opposed to the individual approach of each organist being placed on his own against frequently uncooperative forces at the local level. Nowhere did we suggest that there was a unified approach that could suffice for every denominational situation. We *are* better informed than that. Perhaps it was the limited space devoted to the development of our argument that caused Mr. Fitzer to conclude that the final period of that editorial constituted the limit of our knowledge of the addressed topic. If that is the case, then it is Mr. Fitzer who is uninformed.

Curiously, the gentleman did not direct his criticism to our attention. We would have gladly shared our insight—and then asked: "Why *didn't* you do this before?"

Nonetheless, Mr. Fitzer's verbose, and sometimes redundant, full-page report shows that the Guild is moving in a constructive direction toward an equitable status for musicians. We congratulate him and his Committee for realizing that the organization-to-organization approach can efficiently contribute to a respectful understanding of the Guild's objectives—especially those that would eventually benefit its individual members.

Further to our own argument, we would remind the Guild that the majority of organists seek employment along denominational lines. It would be rare to find a Southern Baptist serving in a Roman Catholic parish, and many Episcopalian and Lutheran organists would prefer to "warm a pew" rather than to accept a position in a Methodist or Presbyterian church. (The variations on this theme are countless.) Of course there are exceptions, but most musicians inherently realize that their effectiveness is diminished when they are placed in a position of leadership in a congregation whose practices or beliefs do not coincide with their own, or are beyond their ability to appreciate. It is also common to find that a prerequisite to a church position is that the musician be a member of the hiring denomination.

Realizing that an organist's employment *generally* adheres to a specific denominational structure, we feel that it is commendable that the Committee on Professional Concerns has initiated a dialogue with "denominational musicians' associations." Hopefully, those discussions will broaden the influence of the Guild, to the benefit of its membership. But those discussions are, at best, well-meaning and uninformed if Mr. Fitzer and his Committee think that "musicians' associations" are the ultimate denominational leaders that need to be confronted.

—David McCain

## THE DIAPASON

A Scranton Gillette Publication

Seventy-fourth Year, No. 9, Whole No. 886  
Established in 1909

SEPTEMBER, 1983  
ISSN 0012-2378

An International Monthly Devoted to the Organ, the Harpsichord and Church Music  
Official Journal of the American Institute of Organbuilders

### CONTENTS

#### FEATURES

A View from the Bench by William Winston	4
Herbert Howells: A Tribute by Gwilym Beechey	6
Organ-Duet Music by Jan Overduin	8
The Secrets of Bach's <i>Passacaglia</i> by Piet Kee (Conclusion)	10
Some Literary References to the Harpsichord and Clavichord: 1855-1923 by Larry Palmer	18

#### REVIEWS

Book Review by Courtney Adams	12
Music for Handbells by Leon Nelson	13
Music for Voices and Organ by James McCray	19
New Recordings	13

#### NEWS

Here & There	14
CCWO Winner Announced	9

#### ORGANS

New	22, 23, 24
Rebuilt	20, 21, 22, 24
Special: A "Modern Portative": Opus 1	20
Unique Italian Organs	21
Electronic	22

#### LETTERS TO THE EDITOR

EDITORIAL	2
CALENDAR	26
CLASSIFIED ADVERTISEMENTS	28

Subscribers: Send subscriptions, inquiries and address changes to THE DIAPASON, 380 Northwest Highway, Des Plaines, IL 60016. Give old and new addresses, including zip codes. Enclose address label from last issue and allow 8 weeks for change to become effective.

No portion of the contents of this issue may be reproduced in any form without the specific written permission of the Editor, except that libraries are authorized to make photocopies of the material contained herein for the purpose of course reserve reading at the rate of one copy for every fifteen students. Such copies may be reused for other courses or for the same course offered subsequently.

#### Editor

DAVID McCAIN

#### Assistant Editor

WESLEY VOS

#### Contributing Editors

LARRY PALMER

Harpsichord

LEON NELSON

Organ and Handbell Music

JAMES McCRAY

Choral Music

BRUCE GUSTAFSON

Musicology

MARGO HALSTED

Carillon

LAURENCE JENKINS

London Correspondent

#### Prices:

1 yr.—\$10.00  
2 yrs.—\$18.00  
3 yrs.—\$26.00  
Single Copy—\$2.00

Back issues over one year old are available only from The Organ Historical Society, Inc., P.O. Box 26811, Richmond, VA 23261, which can supply information on availabilities and prices.

THE DIAPASON (ISSN 0012-2378) is published monthly for \$10 per year by Scranton Gillette Communications, Inc., 380 Northwest Highway, Des Plaines, IL 60016. Phone (312) 298-6622.

Second class postage paid at Des Plaines, IL and additional mailing offices.

POSTMASTER: Send address changes to THE DIAPASON, 380 Northwest Highway, Des Plaines, IL 60016.

Routine items for publication must be received not later than the 1st of the month to assure insertion in the issue for the next month. For advertising copy, the closing date is the 5th. Prospective contributors of articles should request a style sheet. Unsolicited reviews cannot be accepted.

This journal is indexed in The Music Index, annotated in Music Article Guide, and abstracted in RILM Abstracts

## Letters to the Editor

The following letter, received from Susan Tattershall-Petherbridge, regards, in part, her article, "Organ Restoration in Mexico," which appeared in the January 1983 issue of THE DIAPASON.—ed.

I need to make some corrections regarding the article about my work in Mexico. The asterisk in the Ocotlán stoplist, next to the 16' Left Hand Trompetas, should have been noted at the bottom to indicate that the first octave of this Trompeta is at 8' pitch, and only c-c' is 16' pitch. Also, in the Magdalena stoplist, the last stop of the Right Hand is a "Diez y Novena Clara"—embarrassingly enough, I labelled the stop "Deiz y Setena Clara" after having tuned it to the 19a, and having put "diez y novena" in my own dairy-notebook, and having insisted heartily for months that if I had labelled it "diez y setena clara" it most certainly was a "diez y setena clara" (to Guy Bovet, who brought the mistake to my attention). 17a claras are within the tradition, but of larger organs (Mexico City, La Valenciana). Last but not least, San Miguelito has no Docena (as can be seen in the photo); I had hurriedly copied the stoplist of another processional organ, not even imagining that anything about the organito would be printed at all.

I would like to thank all those who have written me in support of these restorations. I was just back down there, and I have not had a chance to write everyone who wrote me. I shall write you all. Please accept my apologies and

be patient. By next New Year, three more organs will be added to the list of playables.

The parish priest of Magdalena, Padre Bruno, has been the guiding energy behind much of this work; he is one of very very few who are interested in the survival of Hispanic/European church music in Mexico. Luckily, he has the support of the Bishop of Tlaxcala, who has permitted him his music teaching and music making, behind the backs of his fellow Diocesan priests, who have complained to the Bishop upon numerous occasions that Bruno's church has "too much polyphony"! Indeed!

He is beginning a Conservatory for the State of Tlaxcala where he will be provided a building and some funds for tuning his 6 or 7 old pianos. But the school really has no resources apart from a half-dozen books of Bach Chorales, and the several brass instruments and recorders that he has managed to collect over the years. I would like to ask the readership of THE DIAPASON to canvas their libraries, attics, and organ benches for *any* and *all* old scores, books of music (even keyboard exercises), and old instruments—especially old string instruments or recorders (please, no guitars)—literally, *anything* you can spare. I drive there twice yearly, and will take anything and everything with me, so as not to risk losing stuff in the mail . . . or perhaps if you're feeling generous, you'd like to Xerox some Gabrieli, or Telemann, or Haendel and send it along. Padre Bruno will be

extremely grateful for all contributions. Don't send money. Send music! You will be remembered in many notes of musical offering.

Susan Petherbridge  
Rt. 6, Box 608  
Leander, TX 78641

\*Lexical error. Susan meant to say *purchase*. —ed.

### Cathedral Organist

In your May 1983 edition, David Pizarro endorsed himself as "Titular Organist, Cathedral Church of St. John the Divine, NYC."

According to the Very Reverend James Park Morton, Dean of the Cathedral, Mr. Paul Halley is currently Organist and Master of the Choristers at the Cathedral Church of St. John the Divine. Mr. Pizarro had occupied that position at one time, but effective July 31, 1977 his employment was terminated and he has not been employed in any capacity by the Cathedral Church since that time.

I hope this sets the record straight.  
Paul Morel  
Accra, Ghana

### Programming

I applaud your editorial in the May 1983 issue of THE DIAPASON (regarding programming for recitals). Your comments were long overdue.

I am a life-long organ enthusiast, and attend all the local recitals. Only rarely do I enjoy everything on the program. I'm lucky if I find *one* work on the program enjoyable. I think the basic problem is musical fraud and a "look at me"

complex among organists.

To my way of thinking, much modern music for the organ is really not music at all, but that has been said before.

It's fine if organists play what *they* like, but they should tailor their programs to their proposed audiences. What is the point of all the years of practice and hard work if no one wants to hear them?

H.V. Scneider  
Sacramento, CA

### "Somnolence Syndrome"

I am one of those pianists who has maintained an active love affair with "The King of Instruments," and much of its repertoire. In spite of what Wagner said about "the organ never breathing," an exciting organ recital can leave me breathless. Unfortunately, few recitals I attend have any level of excitement.

I am amazed at the number of prominent artists who present carefully planned, but very dull, recitals. They draw applause followed by polite hand-shaking ceremonies. (Yawn.) Having already reached their plateau, could it be that these recitalists are jaded? Nevertheless, their performances lack spontaneity. They fail to take the chances needed to communicate, to stir-up the listener.

There is a good reason why it's impossible to get into a Horowitz recital, unless you are willing to stand in line for two days, or can afford black market prices. The level of excitement he creates by his willingness to take chances reaches explosive proportions. His primary goal is to communicate, to give of himself to those who come to hear him. Sadly, many organists aren't concerned

Page 4 ▶



*only a Pipe Organ*  
*is a Pipe Organ*



**REISNER**

with this.

At the root of this "Somnax Syndrome," infecting many a recital, one can find the present day "purist" attitude which has been frightfully growing. Boasting "snob appeal," this attitude is little more than a caricature of old performing styles and instrumental design with such rigid rules that leave little room for creativity and imagination; like wanting to go back to being Neanderthal by wearing soleless shoes.

There is a church in Lancaster (PA) with one of those new "authentic" baroque instruments where I heard an otherwise excellent performance by a young Austrian touring this country. The second part of the program was dominated by Messiaen, which sounded silly on this instrument—rather like a pianist trying to play Rachmaninoff on an anemic clavichord.

As any pianist knows, Bach and Scarlatti work beautifully on the modern piano. But no one would dare to play Chopin or Liszt on the harpsichord.

The organ recital isn't completely dead, but organists will have to get their noses out of the air and work hard if they want to bring back audiences. Otherwise, they will have to be content just playing to each other, eventually putting themselves to sleep.

Barry D. McCall  
Lancaster, PA

### Bach and the Computer

This letter regards Terry, Norman's article, "Bach and the Cross" (THE DIAPASON, March 1983) in which he observes that the number 83 is a prime factor of the total number of measures in Bach's "Eighteen Chorales" and further notes that the numerical equivalent of BACH (14) plus CREUZ ("cross": 69) equals 83. He suggests that this is a more than "happy coincidence" and contends that "the number 83 symbolizes this close relationship between Bach and God."

Using a home computer and a small German phrase book, I rapidly came to an alternative conclusion. Nearing the end of his life, Bach was contemplating death and meant BACH (14) plus FRIEDHOF ("cemetery": 69) equals

83. Or could he have been hungry and meant BACH (14) plus FORELLE ("trout": 69) equals 83?

I then applied Mr. Norman's technique to the "Schubler Chorales." The total number of measures (counting repeats) was 358, which factors into 2X179. I then found that 179 corresponds to FAHRKARTENSCHALTER ("ticket office"). Was Bach contemplating a trip when he wrote these pieces?

I spent just enough time on this "research" to convince myself that a person with patience and a computer could find dozens of words that might correspond to the numbers of measures in Bach's works. Who could say which of these matches is correct?

If evidence exists that Bach counted the measures in his works and intended meaning in those numbers, then we should study that evidence. I would be reluctant, however, to count the measures for him and read unintended significance into them. If this sort of musical scholarship becomes acceptable, a computer programmer could probably link Bach's works with dozens of subjects, and we would be more confused than ever.

James Renne  
Evansville, IN

### Electronics Found Wanting

I found Mr. Junor's article informative and well-written, and wish that all churches planning to purchase a new instrument could have access to it to balance the claims found in the advertising materials of electronic organ builders.

Recently, I took a trip to visit an old friend—a 90-year-old tracker organ. It's a fine instrument which handles music of many periods and nationalities splendidly, on the basis of its own tonal integrity. It has never been rebuilt and, to my knowledge, nothing has been done to it in the past seven years—yet it all works. An hour would be enough time to tune the instrument, and a few more hours spent working on it would have it good as new: hardly the "full-time, never-ending job," nor even the often-claimed great maintenance expense! This instrument is not an isolated example, by any means.

Will any of the latest, biggest, most advanced electronic substitutes be func-

tioning like new in 90 years? Time will tell. (Does anyone buying the latest home sound system really expect to pass it along to their grandchildren, fully functioning and able to hold its own by comparison to anything being built then?)

Rapid advances are being made in the field of electronics with today's latest becoming tomorrow's obsolete. Although the opinion is given in Lawrence Phelps's article that the Digital Computer Organ will not become obsolete, will parts be available for repairs 90 years from now? If the company is still in existence, perhaps they will be, but this is highly unlikely. The tracker organ mentioned above will easily play for another 90 years. Will any electronic organ be able to make the same claim at the end of that time? Will any of the products of today's "regression" in pipe organ building be able to make that claim? Surely many will.

I know of a lot of 25-plus-year-old pipe organs that have not required "substantial alterations or repairs," and none that have had tonal alterations "every few years" unless the organist was fickle. In my experience, where repairs have been required, it has nearly always been to the electrical systems of pipe organs.

Of course there are a few perfectly awful pipe organs, and there are some lackluster instruments—some of which have been imitated by electronic organ builders—but the finest, most elaborate electronic is a far cry, in terms of creating beautiful, living, satisfying music, from the finest pipe organs of the past or of today, regardless of size.

If there are many emotional "pipe-niks" in the organ playing world, it is for good reason. Electronic substitutes have been tried and found wanting. From the standpoint of aesthetic satisfaction a small, beautifully-built pipe organ is preferable to a larger substitute in much the same way as a single rose bud is preferable to a whole bouquet of plastic flowers. (In this case the "rose bud" will last longer than the imitation.)

When comparing a well-built pipe organ to a self-built electronic of equal size, in terms of the stoplist, one will find the electronic to be cheaper. When

comparing them in terms of their sound one will find that he gets that for which he has paid.

After reading all the railing against pipe organs found in Mr. Phelps's article, I cannot help but note that it is the sounds of pipes that the builders of electronic organs are working so hard to copy. Where does that leave us with Phelps's statement, "We only copy what we do not understand"? I'll be convinced of the superiority of electronic substitutes when I see pipe organ ads that claim to have fooled people into believing they were playing a real electronic instrument when, in fact, they were playing a pipe organ!

Marilyn Stulken  
Kenosha, WI

### AGO/OHS Patron Disappointed

I am disappointed that you did not have someone in Chicago check Mr. Junor's diatribe against electronic organs. I don't mind that Junor doesn't like electronic organs or any other kind, but when he gives me "scientific reasons" for not liking them, I rebel. I can't remember seeing so much mis-information in one paper and I'm 76 years old. (B.S. in Chemical Engineering, 1928; Ph.D. in Chemistry, et. al. 1933).

Former pipe builder Lawrence Phelps has an excellent, simple explanation of digital. Forget that Mr. Phelps is talking about organs—he is talking about sound. He is talking about the greatest recording change since electric recording was introduced. Read Mr. Phelps' explanation of digital at least twice, so that you will know what is going on in the world around you. The digital age is already here.

It would take too much space to go through Mr. Junor's many "boners," but I do applaud Mr. Junor's desire to become an organist, . . . he sure ain't no engineer!

I am not a musician, I'm not even an organist. I am a Patron of the American Guild of Organists, and a contributing member of the Organ Historical Society. I own an Allen Digital Computer organ System 603. I take organ lessons.

I have no financial interest in the Allen Organ Company: I have to write to get a copy of the "Tone Card Library."

Page 13 ▶

## A View from the Bench

William Winston

I am furious! I feel betrayed! Just run the gamut of negative feelings and I am experiencing it.

Living in the hinterlands I had so looked forward to the wedding of a family member in one of the larger southern cities. I foresaw the chance to hear some good music.

I arrived at the church earlier than most (natural reflex, I guess) and in the Narthex I found a pamphlet entitled "Our Church at Work" which proved to be a rundown of all their many and sundry activities—including their budget. I rejoiced when I saw that they thought enough of music to pay their Organist-Choirmaster \$24,000.

Entering the church, I was handed a bulletin that listed the prelude music, soloist music, etc. that was to be a part of the wedding celebration. What an organ feast this was to be with many of Bach's major works! I stole a look at the rear gallery which held a handsome case, and by its design I felt sure it was a mechanical-action organ.

Imagine my shock when the Bach *E-flat Major Prelude and Fugue* turned out to be the *C Major Prelude* from the "Eight Little." The whole program was a series of substitutions. The organist did manage to play one or two as scheduled, but what a joke it was!

I felt betrayed. I felt our profession had received a real blow. And I was indignant that she [the organist] should receive such a salary for such shoddy work. I had a strong feeling that perhaps this was a last minute substitute, so after

the service I went to the gallery and indeed found that it was the church's organist who had played.

I managed to tell her only that her playing was "interesting"—and with that my Christian charity peaked.

The organ's builder will go nameless, as no one could ever guess that such a fine instrument could sound so poorly.

I'm an old-timer with 45 years of organ playing under my belt: admittedly, I started at a very young age. Yet, I find it very amusing that many young kids don't seem to think I know anything. I get a real charge out of an "old fogey" reaction.

My church furnishes me with a paid assistant. At present I have a graduate student who could undoubtedly sight-read an all-Reger recital, but when he reaches the final note his ability seems to end right there. He is just beginning to learn that you must take a breath in a hymn, that you don't play the "Outburst of Joy" on Good Friday. (I gave him a service for Good Friday and he showed up a week too early!)

This boy will have his Masters degree in Performance next month. What are his options? A concert career? Come on, just how many make it? Teaching at the college level? Just how many jobs are there? So here is a young man with a fist full of credentials being "dumped" on the church, totally unprepared to do the

only job in his field that is available. What a waste of his time. I see a lot of musical promise in this young man, and will stick with him (if he survives) to see if I can teach him the very fundamental things he should have learned in college. I might add that he is paid well for the amount of time involved, and our having to work around his school schedule.

If he can stick it out, I will leave him with a well-paying job in a year or two, when I retire, and along with that a parish with a history of good music, a congregation that loves and supports our musical effort and a community that has long looked with pride on the efforts of this parish in the field of art and music.

A source of personal concern which seems to elude many an organ teacher recently came to my attention.

I had a call from a clergyman of another denomination in a moderate-sized town some 50 miles away, asking me if I could come and "help" a young girl who was a member of his congregation, but playing in another church. This resulted in my meeting a young woman who had graduated from a "Tracker-Only-Spoken-Here" school. She is playing the organ for a small congregation that has started growing like wildfire, and is faced with a 4-4-1 Estey tubular-pneumatic organ. She's totally buffaloed by this "monster."

Her teacher (who has a rather impeccable reputation) taught her that you "add the Cornet here, and the Krumphorn there" . . . (on a 1918 Estey?). She was completely stymied with no understanding of "making do" all of us have grown so accustomed to. She did not seem to understand when I told her she would have to get hold of some literature that would "go" on this creature.

As I listened to her (quite competently) play, I began to sympathize with the builder who was probably forced to build what the organists of that day demanded, as dictated by the then current fads.

I remember well when the village organist had little status beyond that of a street sweeper. More than likely she was a housewife with 4 years of piano and six Hammond lessons.

Increasingly we find the organist being paid a living wage (although our wives still have to work to make ends meet), and being considered a part of "the team" in the parish hierarchy, and being treated with respect by the parish. I hope that I have, in some small way, helped to make this a reality. I am proud of my profession and bleed a little over what happened at the wedding, wring my hands with my assistant, and grow increasingly impatient with those responsible for the academic responsibility of the coming organists, but I'm sure we'll make it.



For the 1985 Bach Tercentenary  
Anniversary Concordia  
Publishing House  
announces a new edition  
of J. S. Bach's

# ORGELBÜCHLEIN

(in preparation)

Edited by Robert Clark,  
Arizona State University, and  
John D. Peterson, Memphis  
State University, in  
consultation with Peter  
Williams, University of  
Edinburgh, and Russell  
Saunders, Eastman School of  
Music.

A new critical/practical  
edition! Reflects current and

updated Bach scholarship . . .  
faithful to the text and order of  
the autograph but uses  
modern clefs and separate  
pedal staff. Includes the  
chorale in a form available to  
Bach . . . with appropriate  
stanzas of chorale text in  
poetic form in German and  
English . . . plus commentary  
on each chorale prelude and a  
Bach harmonization wherever  
available!



AND

# THE LEIPZIG CHORALES

(in preparation)

Edited by Clark Kelly,  
University of Oklahoma.  
Generally known as The  
Eighteen Great Chorales, this  
new critical-practical edition is  
based upon the manuscript  
collection P 271 in today's  
Deutsche Staatsbibliothek, East

Berlin, and restores many Bach  
autograph readings obscured  
to performers for over two  
centuries. It presents Bach's  
Leipzig chorale-revision  
manuscript (BWV 651-668) with  
the very highest standards of

accuracy and clarity. Format  
includes introduction, preface  
and suggested readings, and  
musical texts (comprised of  
chorale harmonization and  
text, chorale prelude, and  
commentary).

---

## Also in Preparation!

---

### **J. S. Bach and Contemporary Liturgical Life in Leipzig**

Edited by Robin Leaver,  
Latimer House, Oxford,  
England. English translation by  
Herbert Bouman, Daniel  
Poellet, Hilton Oswald.

The first translation of  
renowned Bach scholar  
Günther Stiller's classic  
sourcebook, *J. S. Bach und das  
Leipziger gottesdienstliche  
Leben seiner Zeit*.

### **Bach in Köthen**

Edited by Stephen Daw,  
Birmingham School of Music,  
Birmingham, England. English  
translation by John Page.

The first English translation of  
Friedrich Smend's last major  
work of scholarship,  
substantially revised and  
augmented. An invaluable  
scholarly source—the only  
recent book on an important  
period of Bach's life!

### **Commentary on J. S. Bach's Keyboard Technique**

Quentin Faulkner, Associate  
Professor of Organ, University  
of Nebraska, presents a  
scholarly monograph  
supplement to Concordia's  
new edition of *Orgelbüchlein*.  
Discusses various aspects of  
Bach's keyboard techniques  
with special emphasis on  
fingering.

For more information, write:

*These publications available for  
purchase at the 1984 A.G.O.  
National Convention—  
San Francisco!*



**CONCORDIA**®  
PUBLISHING HOUSE  
3558 SOUTH JEFFERSON AVENUE  
SAINT LOUIS, MISSOURI 63118

# Herbert Howells: A Tribute

Gwilym Beechey

Herbert Howells died in London on February 23rd, 1983, at the age of 90. He was born in Lyndy in Gloucestershire, and at an early age came under the influence of Herbert Brewer with whom he studied at Gloucester Cathedral, before gaining an open scholarship in composition at the Royal College of Music in London in 1912.

At the Royal College he studied with Stanford, Parry, and Charles Wood for about five years. Later, he became an assistant to Walter Alcock at Salisbury Cathedral, but ill health forced him to return to London. In 1920, Herbert Howells began teaching at the Royal College of Music where he remained a member of the staff for well over fifty years, as a widely-admired and respected teacher of composition. In 1936 he succeeded Gustav Holst as Director of Music at St. Paul's Girls' School in Hammersmith, remaining there for just over twenty-five years. For ten years Howells held the position of King Edward Professor of Music at the University of London.

Howells's gifts as a composer with an individual voice and character of his own were very evident in his early years, and he wrote a wide range of music in his years as a student. His early works include some songs, and a piano quartet, *Op 21*, which won a Carnegie prize. The earliest organ works to appear were the *Three Rhapsodies, Op 17*, one of which had been conceived with the Salisbury Cathedral organ in mind and which was inspired by Alcock's playing. The other two rhapsodies were written for Harold Darke and Edward Bairstow; the former was a lifelong friend and colleague of Howells at the Royal College of Music whose organ playing at St. Michael's Cornhill was very influential on English players and students for very many years.

Pieces such as these three *Rhapsodies*, and many other choral and organ works of later years, were written with the grandeur and spectacular dignity of English cathedrals and collegiate chapels in mind. Other influences included the music of Elgar and Vaughan Williams, both of whom were among the composer's close friends. Vaughan Williams's *Fantasia on a Theme of Thomas Tallis* was first performed at Gloucester Cathedral in 1910, and Howells was among many in the audience who were spellbound by this new revitalization of English music of the sixteenth century. Howells admitted that this particular occasion was a turning-point in his musical life, and his own music in later years often exhibited this influence.

Howells's organ piece *Master Tallis's*

*Testament*, the third of the *Six Pieces* which he wrote for Herbert Sumsion and the organ of Gloucester Cathedral in 1940, was just as much an acknowledgement of the influence of Tallis's music as of Vaughan Williams's *Fantasia*.

Howells will best be remembered as a composer of church music—as a com-

poser of motets, anthems and, above all, settings of the English Cathedral Liturgy. His gifts in this field were noticeable again at an early stage of his career, but it was with the appearance of the setting of the Canticles and the Communion Service for King's College, Cambridge (*Collegium Regale*), which was written at the request of Boris Ord during the war years of 1939-45, that Howells established himself at the forefront of church composers of our time.

The *Te Deum* and the *Magnificat* of

ter and Hereford, and for the "Southern Cathedrals"—Chichester, Winchester and Salisbury.

The more ambitious choral works that Howells wrote were crowned by three masterly achievements. The *Hymnus Paradisi* was completed in 1938, but not performed until 1950, the *Missa Sabrinensis* was first given at the Worcester Festival in 1954, and the *Stabat Mater* appeared in 1964. The *Missa Sabrinensis* was the most ambitious of the three, and was appropriately chosen for inclusion in a concert that was given to celebrate the composer's 90th birthday at the Royal Festival Hall in London in 1982.

Howells's songs and other small-scale pieces often show his intimate and heart-warming styles at their best. Among the songs for voice and piano is *King David*, a setting of words by Walter de la Mare, and among his instrumental pieces are the sets of short pieces for the clavichord, *Lambert's Clavichord*, of 1928, and *Howells's Clavichord*, of 1961. A group of anthems that was composed in 1941 include the beautiful setting of words from Psalm 42, "Like as the hart desireth the waterbrooks."

A love of plainsong was a strong influence in Howells's early days in London, and it was an important factor in his creative thinking. In his wonderful setting of "A Spotless Rose," it seems as though he was creating his own plainsong melodies—quite naturally and spontaneously—and fitting them into inimitable harmonies and counterpoints of ineffable beauty.

Another setting of an ancient text was made in 1964 "To the honoured memory of John Fitzgerald Kennedy, President of the United States of America"; a setting to the words of Prudentius in a modern translation by Helen Waddell, "Take him, earth, for cherishing." The solemn dignity of this motet showed Howells at his best, and he was always at his best when writing for choirs he knew, and when composing for texts by which he, himself, had been deeply moved.



Gwilym Beechey received his musical education at the Royal College of Music, and at Cambridge. He is an organist, composer, and a Lecturer in Music at Hull University. Mr. Beechey is also the editor of many organ works of the 17th and 18th centuries.



CHRIST EV. LUTHERAN CHURCH  
COCHRANE, WISCONSIN

THE WICKS ORGAN COMPANY

HIGHLAND, ILLINOIS 62249

Pipe Organ Craftsmen Since 1906

THIS SMALL ORGAN  
enjoys an ideal  
setting adjacent  
to the chancel.

GREAT	PEDAL
16' Gedackt	16' Gedacktbass
8' Principal	8' Principal
8' Holzgedackt	8' Gedackt
4' Octave	4' Octave
4' Rohrgedackt	4' Spillfloete
2 2/3' Gamsquinte	III Mixture
2' Octave	
III Mixture	
SWELL	RESOURCES
8' Spillfloete	16' Gedackt
8' Viola	85 Pipes
4' Waldfloete	8' Principal
4' Fugara	73 Pipes
2 2/3' Gamsquinte	5 1/3' Viola
2' Hohlfloete	78 Pipes
2' Klein Principal	4' Spillfloete
1 1/3' Klein Gamsquinte	61 Pipes
Tremulant	1 1/3' Gamsquinte
	49 Pipes

GENE R. BEDIENT CO.  
TRACKER BUILDERS

344 SOUTH 18TH STREET  
LINCOLN, NEBR. 68508

STEINER-RECK  
Incorporated  
ORGANBUILDERS

P.O. Box 895  
Louisville, Kentucky 40201

#### FOR SALE

This space, as low as \$15 per issue on a 12-insertion contract. Want more details? Rate card sent on request.

THE DIAPASON  
380 Northwest Highway  
Des Plaines, IL 60016



# INSPIRE

Clarion  
4

Hautbois  
8

Trompette  
8

Basson  
16

Plein Jeu  
VI

Doublette  
2

Nasard  
2 2/3

Flöte  
à Fuseau  
2

Octave  
4

Diapason  
8

Bourdon  
8

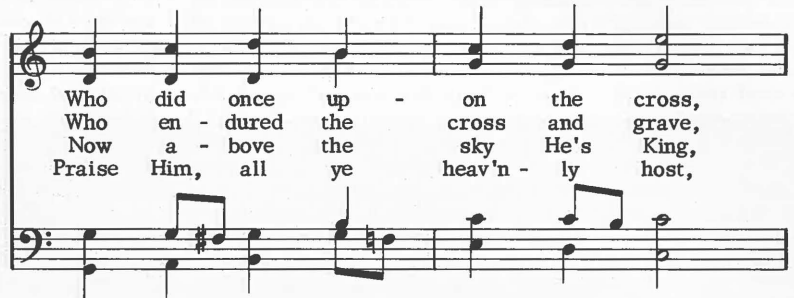

## YOUR CONGREGATION

One of the most inspiring and exciting sounds of a fine organ is the swell reed chorus. A brief passage or occasional hymn verse played on the swell reeds, as contrast to the great flues, can be a magnificent inspiration.

Organists who play the Allen Digital Computer Organ are fortunate to have available the finest of reeds. Allen's reeds always stay in tune with the rest of the organ, maintain perfect regulation, and illustrate the benefit of the Digital Computer System.

Every voice of the Allen Digital Computer Organ is heard in large rich chords. No unified notes to drop out. Our reeds are independent chorus stops.

If you have to apologize for your reeds, maybe you should investigate Allen Organs further.

Name \_\_\_\_\_ WE WOULD LIKE:  
Church \_\_\_\_\_  ALLEN VOICING RECORD (ENCLOSE \$3.00)  
Address \_\_\_\_\_  ALLEN ORGAN BROCHURE  
City \_\_\_\_\_  ALLEN REPRESENTATIVE TO CALL US.  
State \_\_\_\_\_ Zip \_\_\_\_\_ Phone ( \_\_\_\_\_ ) \_\_\_\_\_

...for sound reasons  
Macungie, Pennsylvania 18062  
(215) 966-2202  
COPYRIGHT © 1983



# Organ-Duet Music

Jan Overduin

There is a growing interest in organ-duet music, with more of it being played, published, recorded, and perhaps most significantly, composed. A mostly American-Canadian obstacle to the performance of such music is the prevalence of the radial, concave pedalboard. Such pedalboards are death-traps to any duet team. Fortunately, much of the repertoire is for four hands only. Two fine recordings have appeared recently, one by the female team Marie-Louise Jaquet and Anne-Catherine Plasse, and the other by the father-and-son team Hans and Martin Haselböck. The latter has edited another 19th-century work for two players at one keyboard, the blind Josef Labor's *Organ Fantasy*.<sup>1</sup> This work deserves as much attention as the organ-duet works of Gustav Merkel and Adolf Friedrich Hesse, and is truly a work of great beauty. It consists of two variations, a fugue, and a finale, all on an original theme in E Minor. It requires a large organ: three manuals and pedal. Both organists must use their feet.

Also recently republished are two of Johann Kellner's works: *Zwei Stücke für Orgel zu vier Händen*.<sup>2</sup> One is a lengthy fugue (206 measures) of a not too strict nature, and the other a Haydn-like piece called "Quartetto." The latter contains a composer's note indicating that the work may also be performed by organ and flute (a separate flute part is included).

It is well known that in countries such as England and Austria, Bach's music was originally played of necessity by two players at one keyboard, since pedalboards were either lacking or extremely limited in compass. This was not as novel a concept as it might seem to be today. According to Willi Apel, this was the standard way of playing the organ from fourth to the tenth centuries.<sup>3</sup> As part of his "conclusive evidence" he refers to a depiction on the Obelisk of Theodosius, the picture of the hydraulis in the Utrecht *Psalter*, and the report of Wulstan about the Winchester organ, all of which support this hypothesis. Apel, in fact, believes that it is possible that "four-hand" organ playing even goes back to Byzantine days. So it is the romantic "one-man" show concept that is new and has perhaps been too readily accepted as the only way of playing the organ.

Herman Keller, in his *The Organ Works of Bach* implies that some of Bach's music was regularly performed by two people even in his day. Of "Vater unser" BWV 682 he says that he has "never yet heard the piece performed by one player in an even halfway satisfactory manner."<sup>4</sup> If, as Wilhelm Weisman contends, the various rhythms do indeed symbolize the "hard, cruel world,"<sup>5</sup> then it would be better not to align them. Perhaps Keller exaggerates when he refers to almost insurmountable obstacles, but it is a fact that the work takes on an altogether new kind of vast beauty and clarity when performed by two players, one playing the trio and one the canon, or indeed any other division. Peter Williams wrongly accuses Keller of demanding four manuals:<sup>6</sup> this would happen only if the canon is played on two manuals, an idea Keller mentions, but does not recommend. The virtuoso organist who divides the piece this way may receive a little less glory, but is it the music we present or ourselves?

The recent edition of a Beethoven clock piece<sup>7</sup> points in the same direction. With great difficulty, one person can present a half-baked performance

of it; with two, the music gets off the page. Why is there, among all the unsatisfactory editions of Mozart's organ works, not a similar edition? Arnold Schlick's outrageous 10-part organ setting of the antiphon "Ascendo ad Patrem meum" is another example of a piece all but unplayable by one person, but quite manageable by two, though still just as impressive because of its "incredible fullness of sound and massiveness."<sup>8</sup> True, Apel quotes Schlick as saying that he can play the work by himself, although the way he says this is not entirely clear: "Und zu dem hab ich uff den chorgesang Ascendo ad patrem zu wegen brocht zehen stim; die man in Organis spiln mag, vir stim in dem pedal und sechs in dem manual, als ich sehen und hören lassen kann." (And I have succeeded in setting the chant Ascendo ad Patrem for ten voices, which one may play on the organ, four parts on the pedals and six on the manual, as I can illustrate for the eyes and ears of an audience.)<sup>9</sup> Apel suggests that Schlick must have had special shoes. (With all the emphasis on old fingerings etc., why do we not also hear more about "authentic footwear?") In addition to these rather unusual pieces there is the large body of French Baroque organ music, now usually played by one person, but which originally called for a third, or third and fourth hand, e.g. "Pedalle de Flutte ou une 3 main" in Raison, and all the Quatuors.

One more point in favour of the organ-duet method: it is an excellent teaching-tool. After some 25 years of teaching experience, I believe the main problem in most students to be one of rhythm. All traditional methods seem often to be of little avail when it comes to dealing with this issue. Young organists (and older ones) do not engage in very much ensemble work and for that reason do not have the opportunities to develop as fine a sense of rhythm as other musicians do. Therefore the increase in the availability of good quality organ-duet music is a very fortunate phenomenon. The slightest sloppiness in attacks and releases is of course quickly exposed, but so is any rhythmic inaccuracy or hesitancy. I intend to make use of this tool much more than before. If duet playing is helpful in producing good pianists, a thousand times more so for organists!

Original organ-duet music is available at all levels of difficulty, but even the most elementary exercises can be performed by two people, as opposed to one. Duet works without pedal include Thomas Tomkins "Fancy" and Nicholas Carleton's "Verse."<sup>10</sup> Carleton's "Verse" occasionally divides into ten parts. In a few spots the left-hand part exceeds the compass of the modern keyboard, at which times the pedal could be used (at 16' pitch). Among easy duet works are G. F. Handel's *Zwey Fugen für zwey Personen an einem Clavier*.<sup>11</sup> Both fugues have a short, slow prelude, and are typical of Handel's best contrapuntal style. Organ-duets by Lachner and Schubert<sup>12</sup>, though intended for an organ with pedal, can also be played without making use of the pedal. Schubert's fugue is sober and austere, but also very melodious, while Lachner's is more grand. Hesse's two fantasies<sup>13</sup> also fit in this category. Only the second player uses the pedals, ad lib. Both of Hesse's Fantasies end with a fugue for full organ. These fugues, though somewhat academic, have a drive and a sense of purpose, and when played with a sense of freedom such as that displayed by Marie-Louise Jaquet and Anne-Cather-

ine Plasse on their recent recording, sound very exciting, though one could wish that the climax wouldn't always come on a diminished-seventh chord.

One of the best of this group of early organ-duet works is Samuel Wesley's "Duet."<sup>14</sup> This is a full-fledged three-movement Sonata, the final movement being a long and exciting fugue. The first performance was by Samuel Wesley and Vincent Novello. Forberg Publishing Company has made available a *Prelude and Fugue in B-flat major* by Joh. G. Albrechtsberger,<sup>15</sup> a delightful and easy work that has some of the charming qualities of Haydn's mechanical clock pieces.

The 19th century produced a large number of big works for organ duet, with obligatory pedal. In this category are the Labor *Fantasy* mentioned earlier and Gustav Merkel's *Sonata in d Minor*.<sup>16</sup> Oxford has published the last movement (fugue) separately, which, although it is a very fine fugue, is a shame, since it is thematically and programmatically related to the first movement and therefore sounds incomplete by itself. Works by Baumert, Drath, Engel, Filitz, Loeffler, Schneider, Thiele etc. await republication.

The earliest known American organ duet is Horatio Parker's "Quick March."<sup>17</sup> It is a student piece, written when Parker was 18, and cannot be taken too seriously. The ending is hilarious. Pedals, obligatory, are used only by the second player. Steven R. Quesnel in his *A short Suite* writes in the Romantic tradition.<sup>18</sup> Choir and Swell shutters are a "must" for the first movement. The Double Trio is, as the title suggests, a sextet. The Scherzo makes use of jazz rhythms, and a Paean brings the work to a rousing climax and close. The mood is one of jocundity and mirth, with a touch of sadness, i.e. typically American. A more avant-garde work is David Isele's "Zorgandum,"<sup>19</sup> but the major American organ duet is Rayner Brown's *Organ Sonata for Two Players*,<sup>20</sup> a three-movement work of 15-minute duration, and difficult.

In Canada, both Barrie Cabena and Fred Clarke have composed organ duets, all of which are however still in manuscript.<sup>21</sup> Two of Cabena's three organ-duet works are for four feet only. In this he is probably the only composer other than Alkan<sup>22</sup> who has written a major work for this combination.

Kenneth Leighton's recently published *Dialogues on a Scottish Psalm-Tune*<sup>23</sup> is one of a number of very fine organ duets to come from England. This is a large-scale work of 12-minute duration. Four hands and four feet are required to perform it. It is typical of Leighton's organ music: intense, rhythmic, gritty, always clear in spite of busy counterpoint, e.g. a double fugue

in the middle, based on the first line of the hymn. Universal has published Elisabeth Luytens' *Plenum IV for Organ Duet*.<sup>24</sup> The style of this work is neo-romantic, and in spite of the title, most of the work is at very soft dynamic levels. The resources of the organ are imaginatively explored, and an instrument of at least medium size is required. Another intensely poetic work is Stephen Oliver's *Kyoto*.<sup>25</sup> This work was written in 1977 for the well-known duet team Stephen and Nicholas Cleobury. Like the city that inspired it, it is a work of many contrasts. The title is joined to a short poem:

Except for you,  
whom could I ever love,  
never surfeiting?

Nothing remotely suggests  
the charm of her appearance

Even plants and trees  
share in the bitter grief  
of the ancient capital.

It is a difficult one-movement work (four hands and four feet).

In France it is Jean Langlais who has made two valuable contributions to organ-duet repertoire. His two fantasies<sup>26</sup> are, like all of his music, full of colour and rhythmic vitality. Fairly large organs are called for (though we have done them with success on an 18-rank two-manual tracker), and there is some virtuoso four-part pedal work in each. *Double Fantasie* is a two-movement work, the first very free in style, and the second an exhilarating fugue. Total playing time is about ten minutes. The *Deuxième Fantasie* is a one-movement work in similar fantasy style, though perhaps somewhat more gritty harmonically, and irregular, rhythmically. Both works are difficult.

So much for a short description of some of the music presently available for those who wish to pursue it. More is being composed and published or republished continually, proving that this old tradition, though it may have gone underground for a few centuries, is still alive and well.

In some ways, it is more difficult to play with a partner. One is in a physically awkward position at the end of the bench, and attacks and especially releases need to be co-ordinated. Ritardandos and accelerandos are major challenges. There is no conductor to rely on. Collisions and entanglements are inevitable, especially if one also does one's own registration. Yet, other things become easier. We have with ease performed pieces that are technically fiendishly difficult for one performer, e.g. Jean Berveiller's *Cadence*. Cheating? Perhaps. But if the choice is between a good performance by two players or a poor one by one, which would you choose? ■

## NOTES

<sup>1</sup>Labor, Josef: "Orgel-Fantasie für zwei Spieler" op. 12, ed. Martin Haselböck and Thomas Daniel Schlee. Universal Edition 17171.

<sup>2</sup>Kellner, Johann Christoph: "Zwei Stücke für Orgel zu vier Händen (Flöte und Orgel ad libitum)", ed. Hermann J. Busch. Rob. Forberg Musikverlag.

<sup>3</sup>Apel, Willi. *The History of Keyboard Music to 1700*, tr. and rev. Hans Tischler (Bloomington: Indiana University Press) pp. 20-23.

<sup>4</sup>Keller, Hermann. *The Organ Works of Bach*, tr. Helen Hewitt (New York: C. F. Peters), p. 280.

<sup>5</sup>*Ibid.*, p. 279.

<sup>6</sup>Williams, Peter. *The Organ Music of J.S. Bach* (London: Cambridge University Press) Vol. 11, p. 211.

<sup>7</sup>Beethoven, Ludwig van: "Adagio für die Flöten", ed. Martin Haselböck and Thomas Daniel Schlee. Universal Edition 17466.

<sup>8</sup>Apel, p. 90.

<sup>9</sup>Apel, pp. 90, 91.

<sup>10</sup>Tomkins, Thomas and Carleton, Nicholas: "For Two to Play", ed. Franz Peter Goebels. Nagels Musik-Archiv, p. 237.

<sup>11</sup>Händel, G. F.: "Zwey Fugen für zwey Personen an einem Clavier", ed. Heinz Schüngeler. Heinrichshofen's Verlag.

<sup>12</sup>Schubert, Franz: "Fuge e-moll", op. posth. 152, ed. Otto Biba. Verlag Doblinger No. 652. Lachner, Franz: "Introduktion und Fuge", ed. Otto Biba. Verlag Doblinger No. 653.

<sup>13</sup>Hesse, Adolf Friedrich: "Zwei Fantasien", op. 35 and 87, ed. Martin Weyer. Rob. Forberg Musikverlag.

<sup>14</sup>Wesley, Samuel: "Duet for Organ", ed. Walter Emery. Novello.

<sup>15</sup>Albrechtsberger, Joh. G.: "Präludium und Fuge für Klavier oder Orgel zu vier Händen", ed. Hermann J. Busch. Rob. Forberg Musikverlag.

<sup>16</sup>Merkel, Gustav: "Sonate op. 30 d-moll für die Orgel zu vier Händen", ed. Hermann J. Busch. Rob. Forberg Musikverlag.

<sup>17</sup>Parker, Horatio: "Quick March", ed. William Osborne. Hope Publishing Company.

<sup>18</sup>Quesnel, Steven R.: "A Short Suite for Organ (4 hands, 4 feet)". Gentry Publications #676.

<sup>19</sup>Isele, David: "Zorgandum". Hinshaw.

<sup>20</sup>Brown, Rayner: "Organ Sonata for Two Players". Western International Music.

<sup>21</sup>Clarke, Frederick Robert Charles: "Duet for Organ, Two Performers, 3 Manuals". MS. Cabena, H. Barrie: "Homage to Karg-Elert: 54 Studies on a ground bass", (four feet), "Sonata XII" (four feet) and "Theme and Variations" (four hands and three feet). All MS.

<sup>22</sup>Alkan, Charles Henri Valentin: "Bombardo-Carillon für Orgel zu vier Füßen", ed. Hermann J. Busch. Rob. Forberg Musikverlag. According to Busch, the piece is a study in tone-painting, although the title can be interpreted in at least three totally different ways. This is a much easier and shorter work than the two by Cabena.

<sup>23</sup>Leighton, Kenneth: "Martyrs. Dialogues on a Scottish Psalm-Tune for Organ Duet", op. 73. Novello. (Written for Nicholas and Stephen Cleobury).

<sup>24</sup>Luytens, Elisabeth: "Plenum IV". Universal. (Written for Nicholas and Stephen Cleobury).

<sup>25</sup>Oliver, Stephen: "Kyoto". Novello.

<sup>26</sup>Langlais, Jean: "Double Fantasie" and "Deuxième Fantasie" in *Mosaïques I and III*. Combre.

Jan Overduin is an Assistant Professor of Music at Wilfrid Laurier University, Waterloo, Ontario. Along with Barrie Cabena, he has appeared in numerous organ-duet recitals, and on programs of the Canadian Broadcasting Company.





## CCWO Winner Announced

Anne Carolyn Wilson, winner of the Gruenstein Organ Contest sponsored by the Chicago Club of Women Organists, will be presented in recital on October 2, 1983 at the First United Church of Oak Park, 848 Lake St., Oak Park, IL.

Mrs. Wilson is the Associate Organist at the Episcopal Cathedral of the Incarnation in Garden City, NY. She has previously held church positions in Toledo and Cincinnati. She is a frequent recitalist and often appears in duo-keyboard programs with her husband, Todd Wilson. She is on the music faculty of Adelphi University and is an active member of the American Guild of Organists

from which she holds the Associate certificate.

Wilson was the winner of the First Annual Diane Bish International Organ Competition in January of this year, and was named first runner-up in the National Organ Playing Competition sponsored by the First Presbyterian Church of Fort Wayne, IN.

Anne Wilson received her Bachelor's and Master's degrees in Organ Performance from the University of Cincinnati College-Conservatory of Music where she was a student of Roberta Gary.

## 12th Annual UNDERGRADUATE ORGAN COMPETITION

of the  
**FIRST PRESBYTERIAN  
CHURCH**

Ottumwa, Iowa  
Sunday April 8, 1984, 1:00 p.m.  
1st Prize: \$600 2nd Prize: \$300  
For information & application  
Competition '84  
P.O. Box 733  
Ottumwa, Iowa 52501  
Application Deadline  
February 15, 1984

# "REISNER Reliability Sold Me!"

"I've used thousands of Reisner 601 direct electric chest magnets in the past 35 years, because of the integrity of the product and the company behind it." That's why Washington, D.C. rebuilder Harold Newcomer installed Reisner 601's in the 90 rank, Aeolian-Skinner pipe organ at the National Cathedral. For a compact, inexpensive, light-weight, easily installed, replacement for leather pouches... Today's most reliable answer is simply, the 601 magnet from the craftsman's supplier...

**Reisner, Inc.**  
240 N. Prospect Street  
P. O. Box 71  
Hagerstown, Maryland 21740  
(301) 733-2650

# The Secrets of Bach's *Passacaglia*

Piet Kee

In this final installment of his discussion of Bach's *Passacaglia in C Minor*, Piet Kee further explores possible number symbolism. He also outlines implications for registration of the work and some interesting connections between Bach, Buxtehude, and Werckmeister.

## NUMBER SYMBOLISM AND DISPOSITIO

On page 5 of the July Issue I signaled the Division Number which functions as a milestone or dividing line in the variation part of the *Passacaglia*. The dividing line marks the *golden section*. This *divina proportio* is based on the division of a line into two unequal parts; the smaller part is proportional to the larger as the larger to the whole. The numerical proportion used by Bach corresponds to the Fibonacci series, a method for arriving at the golden section. In this series, each member is the sum of the previous two members; (1,2) 3,5,8,13,21,34,55 etc. The higher the number chosen and divided by its predecessor, the closer the golden section is approached:  $13:21 = 1.6154$ , the golden section being 1.6180. The Fibonacci (c. 1180-c.1250) series was much used in the Renaissance and Baroque.

Once again an overview of the two groupings on which the *passacaglia* is based:

A: Subdivisions according to the Lord's Prayer							
Group .....	I (IA)	II	III	IV	V	VI	VII
Number of statements ...	1	2	3	4	3	2	3+3=6
contained		3					
B: 21 by addition							
Group .....	I (IA)	II	III	IV	V	VI	
Number of statements ...	1	2	3	4	5(3+2)	6(3+3)	
contained		3					

At first glance, B seems to have little right to exist. The only differences are as follows. First, A is clearly symmetric in the center area: 2 3 4 3 2; the obvious symmetrical sums in B lead to 7:  $1+6=7$ ,  $2+5=7$ ,  $3+4=7$ . Secondly, by fusion of Groups V and VI, A produces B; in B the number of each group is equal to the number of statements contained in it.

Still, that is not all. It is primarily the second grouping which is responsible for the number 21 by the addition of 1,2,3,4,5,6. Moreover, it is interesting to note that 21 can also be reached paradoxically by multiplication:  $3 \times 7$ . The beginning of the statements 7 and 14 are shown to be important structural moments (21 contains the "Septenarium" thrice, according to Walther).

The second grouping is not just for private amusement. As is the case with many aspects of this article, here we touch on a subject whose importance extends far beyond the *Passacaglia*, although precisely this work is excellently suited to its application. This division into six groups is a "secret" division and has special significances for number symbolism, traditionally an occult subject. As of old, the elementary geometrical figures are allied to the symbolism of the small natural numbers. As in developing a photograph, when applying Bach's secret grouping these figures become visible.

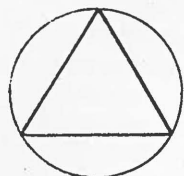

The (equilateral) triangle is the first to appear: the triple division of Group III. In geometry, the triangle is derived from the circle, symbol of the divine eternity. To use Werckmeister's words, the 3 originates in the "Unität", "the Beginning without beginning." The triangle is a figure which since ancient times has symbolized that which is higher, divine; "Thy Kingdom come."

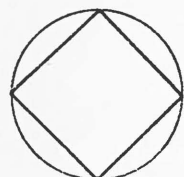

With the quadruple division of Group IV follows the allusion to the square, the second figure which can be geometrically constructed in the circle. The square is considered to be the symbol of matter, the earth. "Thy will be done on earth as it is in Heaven."

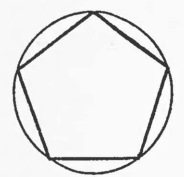

The equilateral pentagon is difficult to construct in the circle. In the Middle Ages it was known and used, but its method of construction was kept secret and was revealed only to initiates. This figure is derived from the *golden section*, and vice versa. In the *passacaglia*, the group of five statements is "visible" only through the secret division, and it is arrived at by the application of the golden section!

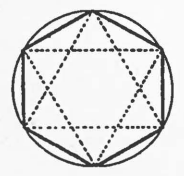

The hexagon leads back to the first figure, and is arrived at by making two triangles in one circle. The *complexio* of the *passacaglia* V also leads us back to the first figure, whereby Group VI also consists of two "triangles."

The heptagon cannot be constructed geometrically in the circle and is left out of Bach's six-part grouping.

The number 6 of grouping B also corresponds to the "sechs Redeteile," the six parts of a speech in the rhetorical *dispositio*. The various phases of the composing process also appear in rhetoric: *inventio* (the invention or idea), *dispositio* (the plan of the composition, the large line), *elaboratio* or *decoratio* (the working out). In my analysis I have already discussed several *elaboratio* figures. The *dispositio* also plays

a part in the construction of the *Passacaglia*. A quotation from Mattheson's *Der vollkommene Capellmeister*: "our musical Disposition differs from the rhetorical arrangement of a speech only in the subject, theme or purpose: from there on it must observe the same six parts prescribed to the orator, namely, the introduction, reportage, proposition, the corroboration, rebuttal and the close. Exordium, Narratio, Propositio, Confirmatio, Confutatio & Peroratio."<sup>34</sup> The six parts can also be applied to the *Passacaglia*, whereby the fugue may be regarded as the *peroratio*.

The numbers 3, 7, 14, and 21 are dominant in the variation section. A few examples:

- The references to the Trinity are legion.
- Group III consists of three parts and begins at the seventh statement.
- The combination of Groups III and IV yields seven statements, from number 7 to 14.
- Bach's "*Gebeth des Herrn*" consists of seven parts, each beginning with one of the seven days of the creation.
- 14, the number of BACH is also the number of the statement which begins on the dividing line of the *passacaglia*.

The number 8 is a symbol of rebirth; many baptistries, for example, are in the shape of an octagon. This illuminates the function of Bach's *complexio* once again: the last three statements are a "rebirth" of the first statements.

The numbers 3 and especially 12 dominate the fugue; 12 is the number of the twelve apostles and of the church, also in the material sense: the "ideal plan" of a medieval cathedral has twelve bays over the length.<sup>35</sup> The mirror 12-21, moreover, is reminiscent of the mirror image of Bach's name, 14-41 (BACH-JSBACH).<sup>36</sup>

Werckmeister's *Musicalische Paradoxal-Discourse* has now taken on a new meaning for the significance of numbers in the work of Bach.<sup>37</sup> In this area an enormous amount of speculation has been done. Analyses using complicated computations have pictured Bach as some kind of super-mathematician. Without having to doubt his capacities in this field we can conclude that Bach proceeded in a human way from small natural numbers in his *Passacaglia*.

## MANUSCRIPTS

Unfortunately, no autograph of the *Passacaglia* is any longer at our disposal. However, a large number of copies, probably made between 1707 and some point over a hundred years later, have been preserved.<sup>38</sup> A comparison of these manuscripts reveals considerable differences in the musical text. In this article I must restrict myself to noting only a few sources and text variants. Partly with a view to dating the *Passacaglia* and to certain "operating instructions" I shall refer to three of the oldest manuscripts: the Andreas-Bach-Buch, P-803 and the source of the Peters edition.

The *Andreas-Bach-Buch* (abbreviated ABB) is named after one of its early owners, Johann Andreas Bach (1713-79), who was a son of Bach's eldest brother Johann Christoph (1671-1721). It is one of the richest sources for our knowledge of the German organ literature of the baroque, containing 55 organ and harpsichord compositions by J. S. Bach (15 works), D. Buxtehude (7), G. Böhm (5), J. Kuhnau (5), J. Pachelbel (4) and others. Besides P. Telemann, Johann Sebastian is the youngest composer represented in this collection. The book is the work of one "main copyist" and ten collaborators. Identification of the main copyist is extremely difficult; the most recent hypotheses are by Kilian<sup>39</sup> and Schulze<sup>40</sup>, who respectively propose Johann Bernhard Bach I (1676-1749) and the earlier named Johann Christoph Bach as the most likely candidates. In regard to the time of inception of the *Passacaglia* manuscript in this book the opinions are also divided, varying between c.1707 and the middle of the 18th century. It is expected that new facts will be brought to light in the near future.

P-803 is a collected volume from the estate of Johann Ludwig Krebs (1713-80), one of Bach's best known pupils. It contains almost exclusively compositions by J. S. Bach. Most of the copies in it were made by Johann Gottfried Walther (1684-1748), Johann Ludwig Krebs and Johann Tobias Krebs (1690-1762), from whose hand also the *Passacaglia* derives. According to research by Lohmann, the pages bearing the *Passacaglia* can be dated no later than 1714.

The source of the Peters edition: Griepenkerl states in his preface to the 1844 edition that he has had access to a large number of copies. He writes, "all those copies, however, are inferior to one single copy, which Herr Gleichauf in Frankfurt-am-Main made from the autograph in the possession of Herr Kapellmeister Guhr upon our request. [...] our edition is based on this supreme authority." Since then, both copy and autograph have disappeared. Moreover, it is uncertain whether Guhr owned a genuine autograph, since various Bach manuscripts in his possession were Meisner copies. Gottlob Meisner (1707-60) was a pupil at the Thomasschule in Leipzig from 1719 to 1729 and copied many of Bach's works during that period: his handwriting must have borne a strong resemblance to Bach's.<sup>41</sup>

The Peters edition shows striking deviations in comparison with the other manuscripts; these are musically very intriguing. It is possible (probable, I think) that during Bach's Leipzig period Meisner copied the autograph of the *Passacaglia* with corrections which Bach had supplied after the initial composition. This could account for the discrepancy between ABB and Griepenkerl's copy. His source was probably very close to the autograph, and in any case, there were sufficient reasons for me to choose this edition as the departure point for the musical text.

In regard to the dating of the *Passacaglia*, it may be said that its inception cannot be pinpointed by studying the manuscripts alone. This is a matter of continuing study. I can only assert that ABB and P-803 point towards an early inception date. In the last section of this article I shall return to the subject of dating.

I shall choose two peculiarities present in the Peters edition which are not found in other manuscripts. They are both concerned with articulation and are important to the way in which I have discussed the music in this article.

1. The slurs in the fugue subject. These parallel the syncopated accentuation which I pointed out in the fugue subject. In this connection it is perhaps of interest to note a variant division of the beam in other manuscripts:<sup>42</sup>

in four MSS, including ABB

in five MSS, including P-803

The pronunciation of "vanitas," beginning after a rest, may also be a piquant clue to the articulation.

2. The slurs in statement 14. Earlier, I noted that this statement—uniquely—is carefully supplied with performance instructions. They have been drawn in with evident relish and



refer to typical baroque articulations also prescribed in many other works by Bach. Of course it is conceivable that they are in Meiszner's or someone else's hand, but it is more likely that they are Bach's own additions.

## INTERPRETATION

### Registration

It is probable that the *Passacaglia* was composed between mid-1707 and mid-1708 (See the chronology in the Epilogue section of this article). What is the most adequate type of organ for this work? What organs did Bach have access to during that period?

Arnstadt, Bonifatiuskirche (August 9, 1703-June 29, 1707)  
Oberwerk 10 stops, Brustwerk 8, Pedal 5.

Mühlhausen, Divi Blasii (July 1, 1707-June 25, 1708)

Oberwerk 10, Rückpositif 9, Pedal 9 (in 1708/09 rebuilt according to Bach's specifications and enlarged with a Brustwerk)

These are two fairly large two-manual instruments. The plans for enlargement of the Mühlhausen organ were made in the same period<sup>43</sup>, while Bach's memories of his study trip to Buxtehude in 1705/06 and of the large Lübeck organs must have been most vivid. All this, together with the character of the work and the hypothesis to be presented in the following paragraph, makes it credible to maintain that Bach was thinking of a three-manual organ while composing the *Passacaglia*.

The balance between the overall line and the details is a source of many performance problems. All too often the *Passacaglia* has been the victim of excess attention to detail, and therefore too colorful registrations. Albert Schweitzer advises in 1907 to "begin pianissimo on the third manual, and add a few stops at each new variation."<sup>44</sup> Of course, Schweitzer was wearing the spectacles of the romantic era. The enormous reorientation on history which meanwhile has taken place unfortunately often leads to another extreme—overly plain registrations, due to overestimating the large line and neglecting the detail. I cite Jacobus Kloppers in this connection: "The work itself and its performance must form a unity. Neither the view that evidences the infusion of arbitrary sentiments, nor the opinion that the musical text is something complete, which demands simply to be played out, can be defended."<sup>45</sup>

The obvious thing to do is to accompany the division into groups by changes of manual. Due to uncertainty regarding the groupings until now this has presented problems. The *Gebeth des Herrn* and especially the *Radical-Zahlen* prove to be reliable guidelines which pinpoint the beginning of each group. At such moments manual changes are very natural maneuvers. Only the opening of Group IV (statement 10) is an exception—it is no accident that precisely this group joins with Group III to form a whole, whereby the complex of 7 is created!

Each group makes its own demands and has its own possibilities. Bach's subtle development of his plan obliges us to register in a likewise subtle manner, without necessarily drifting to "romantic" excesses. Three elements of the variation part make up its "backbone": Statements 1 to 4 (Groups 1+1A), 7 to 13 (III+IV) and 19 to 21 (VII), supporting points which are anchored in the Lord's Prayer and the *dispositio*. For these it is sensible to use the backbone of the organ—the principals. But how extensive should the principal choruses be? Everyone will probably agree that the group of the *numerus plenus* (Group VII) requires a plenum. This does not mean that the plenum is also obligatory for Groups 1+1A. There are various reasons why the beginning of the *Passacaglia* can be registered differently. There is naturally the connection with the *complexio* and a plenum is therefore certainly one of the possibilities.<sup>46</sup> However, Group VII is a varied recapitulation, therefore Group 1A can have a "varied" registration without undermining the "enlacement." The relaxed rhythm of the first statements leaves elbowroom for registration possibilities. A small plenum, e.g. 8', 4', 2' or even a principal 8' alone may be very appropriate. Also the Lord's Prayer is a valuable guide. There are many ways of praying, even when the words of the prayer are fixed. Saying the doxology will not contribute much variation (this is the parallel of Group VII), but the invocation "Our Father, who art in heaven" can sound differently from one person to the next.

Group III lies between these poles; its registration will have to be related to Group I to some extent. In Group IV the possibility exists to play the right hand part of statement 11 with a louder registration starting with c<sup>3</sup> (the other alternative is to let the left hand escape to a manual with a softer registration). In statement 12 the left hand joins it, and in statement 13 this sound provides the high point of the seven-part formation.

In Groups II and V there are opportunities for alternating sound colors, in the first place, the flutes. Especially the *confutatio* character of Group V demands contrasting sounds. At the human number, about which Werckmeister has much to say, and which provided Bach with inspiration for three most characteristic manual variations, the desire for a three-manual organ can be strongly felt. It is certainly possible to use Great and Positive (for right hand and left hand, respectively) for the two-manual treatment invited by statement 15, but Positive and either Bovenwerk or Brustwerk will usually fit the registration plan better (Positive: principals; Bovenwerk or Brustwerk: flutes). For the playful and "lovely" attributes of statement 16, "playful" use of a third or fourth manual may be appropriate.

Group VI calls for another contrast and is usually delegated to the Positive. The harmonic tensions of statement 17 make the most intense effect with the full principal chorus; the triplet passagework of statement 18 is best served by the light touch of a positive. The liberation by the "numerus plenus" can be best expressed by a manual change, beginning in measure 144c with the right hand on the Great (which will often be coupled to the Positive) while letting the left hand finish its task.

### Manner of Playing

All that has been discussed so far—Bach's intentions with the Lord's Prayer, Werckmeister's ideas, and their grandiose development; the use of a good musical text, the choice of sensible registration—all this comes to life only by virtue of an adequate manner of playing. It is striking to read what early authors have to say about the *elocutio*, the rhetorical name of the performance,<sup>47</sup> and to note how much importance they placed on using the *Affecten*. In this area as well, the newly discovered foundations of the *Passacaglia* are valuable aids.

An *Affect*, however, requires good articulation to come to life. What an orator has to say is absorbed by his listeners only when it is well said and, above all, when it is well pronounced. By this is meant speechlike articulation that is based on histori-

cal insights, such as instructions left by composers themselves, including Bach, as well as on characteristic accentuation. Just as 19th or 20th century approaches have blocked the way to understanding the essence of the *Passacaglia*, a 19th or 20th century manner of playing can hamper the intelligibility of the piece.

Several comments in this connection: Group II, the *figura corta*. Good "pronunciation" adds to the effect of the *elaboratio* and makes the rhetorical figures clear. The difference between stepwise motion and leapwise motion goes together with a difference in playing manner. The 16th-notes in statement 6 will have to be more separated than those in statement 5.

Group III. Statement 9, which "flows out of both the preceding 1 and 2," demands sensitive agogic timing for its contrary motion, so that "one hears something different."

The entrance of Group IV cannot be marked by a change of manual or of registration, but certainly it can be marked by articulation. The leapwise motion of the broken chords in statement 10 is different in nature from the leapwise motion of statement 6, and it needs to be tackled differently. The solo part of statement 11 gives an interesting performance clue—the leap c<sup>1</sup>-b<sup>2</sup>. This is clear only when one plays on two manuals, whereby the right hand is forced to jump from one note to another. One should not see it as a necessary evil, but as an invitation to "affective" playing. It goes without saying that when this passage is repeated in the lower voice of the following statement, it should be played by the left hand alone. The articulation produced is similar to the example of the *tirata perfecta* shown in Walther's *Lexicon*.



Group V. In statement 14 we possess a beautiful specimen of authentic articulation. Even if the indications are by Meiszner or another contemporary they are of great value. They are evidence of how delicately the leap in such a figure was treated—sometimes "geschleift"<sup>48</sup> and sometimes purposely not. Statement 16 supplies another authentic indication, the division of the hands. The groups of two 16th-notes, the consequence of the rhythmic thinning-out process, are to be played one hand after the other in turn, whereby slight separations arise almost automatically.

Group VI, statement 17: "Forgive us our debts as we forgive our debtors." For the stirring harmonies, a stirring interpretation is necessary.

Group VII: "is delivered from evil." Expressive handling of the appoggiaturas can help to underline this.

The fugue issues from the passacaglia and is joined to it by a dovetail construction. It goes without saying that the custom of many organists of stopping after the chord in measure 168c and beginning anew with the c<sup>1</sup> of the fugue subject is in conflict with this construction. "Amen" is said immediately after the prayer. The long fugue must not be a weighty Amen; the co-subject, which determines the character of the fugue to a great extent, invites a vigorous attack and clearly audible tone repetitions.

Finally, the general pause. I have already mentioned that it is intended as a rhetorical effect, a rest that cleaves the second half of the passacaglia theme down the middle. A conceited improvisation would deflate the tension and cruelly disturb this effect.

## EPILOGUE: BUXTEHUDE-BACH

In 1873 Spitta wrote about the *Passacaglia*,<sup>49</sup> "If it had been regarded as a product of Bach's later period this was due to insufficient awareness of its peculiar relation to Buxtehude, of whom the composition clearly reminds us, both in details and as a whole. The misconception was also due to underestimating the quality of one particular source and to underestimating the height of Bach's Weimar achievements, especially for the organ." Further on, in response to statements 2, 3, 4, 11, 15, 16: "Being to some extent diametrically opposed to Bachian sentiment by virtue of its youthful exuberance, the genuine Buxtehudian character is far too clearly present here, and it arouses suspicion of an intentional link."

Since Spitta, nearly every author concerned with the *Passacaglia* has noted the correspondence with Buxtehude. In my article as well, the name turns up frequently. Is it only due to Buxtehude's influence, or does it have to do with allusions? Is there a conscious link, or perhaps even more? The newly discovered background stimulates the search for an answer, and it throws new light upon certain circumstances.

Bach's admiration for Buxtehude is known; his pilgrimage to Lübeck is a favorite subject in the biographical literature. Between Buxtehude and Werckmeister a friendship existed, to which the two laudatory poems which Buxtehude dedicated to "his highly esteemed friend" on the occasion of the appearance of the latter's *Harmonologia Musica* in 1702, testify.<sup>50</sup> It may be assumed that Bach made early acquaintance with the *Musicalische Paradoxal-Discourse*. Dammann writes, "It is probable that J. S. Bach too had become acquainted with Werckmeister's dissertations through Bach's nephew and friend J. G. Walther, who had studied with Werckmeister in Halberstadt in 1704 and had received gift copies of his treatises."<sup>51</sup>

With this, the contours of the triangle Bach-Buxtehude-Werckmeister are more sharply defined. I should like to launch the following hypothesis: *Bach wrote his Passacaglia as an homage in memoriam to Buxtehude not long after the latter's death and not long after the publication of the Musicalische Paradoxal-Discourse. For this he used a compositional form in which Buxtehude had excelled, together with the material written by one of Buxtehude's friends. Simultaneously he wished to signalize the importance of harmonic proportions.*

Besides the circumstances already mentioned, a few additional arguments: Bach's theme is in fact an extension and variant of Buxtehude's passacaglia theme, and is itself an homage to the master from Lübeck. As the first half contains an allusion to the *Vater Unser*, the second half contains an allusion to Buxtehude's name. ▶

tonal materials of the first half are C, E<sup>b</sup>, F, G, A<sup>b</sup>; the remaining tones of the harmonic minor scale, D and B (the B being a B-quarrée, raised B<sup>b</sup> or H), correspond to the initials DBH which were the customary abbreviation of Dietrich Buxtehude.<sup>52</sup>



Buxtehude is the only North German composer to have expanded the ostinato forms well-loved by the South German masters into grand, independent organ works. His passacaglia and two ciaconas are milestones in the organ literature. Bach probably admired them very much. Furthermore, in his only composition in this genre, Bach realized a synthesis of passacaglia (theme mainly in the bass voice) and ciacona (theme also in other voices).

Another point of contact is the number 7. It is possible that, besides the connection with Werckmeister's seven *Radical-Zahlen*, Bach intended the number 7 to allude also to the significance Buxtehude had given it. First, for example, Bux 161 consists of four parts, each of which sounds the seven-note theme seven times. Second, Buxtehude's harpsichord compositions include "7 Klavier-Suiten, in denen die Natur und Eigenschaft der Planeten artig abgebildet sind" (in which the nature and properties of the planets are artfully portrayed), Bux 251. They are explicitly listed on page 130 of Mattheson's *Vollkommene Capellmeister*. Since then the suites have been lost. We are curious to know when this opus was composed, and whether the number 7 played any unusual role in it. Is it related to the *Radical-Zahlen*? That would not have been impossible, for Kepler had already established a connection between these numbers and the seven planets known at that time. Might a point of contact with Bach also be found here?

I shall list some important dates:

Bach visits Buxtehude in Lübeck	Winter 1705/06
Werckmeister	Nov. 30, 1645-Oct. 26, 1706
Buxtehude	1637-May 9, 1707
Publication of <i>Musicalische Paradoxal-Discourse</i>	1707
Bach's post as organist at Arnstadt	Aug. 9, 1703-June 29, 1707
Bach's post as organist at Mühlhausen	July 1, 1707-June 26, 1708
Walther's <i>Praecepta</i> finished	March 1708
Bach takes up post in Weimar	July 1708

In this survey the period from mid-1707 to mid-1708 stands out as a possible inception period of the *Passacaglia*.

In this context I must again refer to the *Andreas-Bach-Buch*. First, it contains seven works by Buxtehude. The main copyist must have known Buxtehude—at least his work—fairly well. Second, the book contains no fewer than seven ciaconas or passacaglias. Besides "our" *Passacaglia* it contains the famous D minor ciacona by Pachelbel, Böhm's suite in D major (with ciacona), Bux 137 (with ciacona), Bux 159, Bux 160 and Bux 161. For Buxtehude's ostinato works this is the sole extant source. Evidently, the main copyist, who also must have been the initiator in assembling this book, must have had a preference for this genre.<sup>53</sup> Is there more behind it? Did the main copyist perhaps commission Bach's *Passacaglia*? Was he a key personage in respect of the triangle Bach-Buxtehude-Werckmeister? In the case of Johann Bernhard Bach this is certainly conceivable; he was the teacher of Johann Gottfried Walther and may have been well posted on the latter's contacts with Werckmeister. He also must have had many contacts with Johann Sebastian Bach.<sup>54</sup> It is possible that the main copyist of the *Andreas-Bach-Buch*, whoever he was, was an initiate who knew all the secrets of Bach's *Passacaglia*. He will have also realized what a summit this work represented, not only in its genre, but also of musical culture in general.

For the generations after Bach, the *Passacaglia* has been a well-loved but problematical piece. For several centuries, the correct approach has been sought. Now that many mysteries have been finally unveiled, it is again possible to see this work of art as the composer intended it, to look on it as its creator looked on it. . .

Haarlem, 1 June 1982

## Book Review

Wilfrid Mellers. *Beethoven and the Voice of God*. Oxford University Press, 1983. 453+ pp. \$49.95.

Teachers of music history will be attracted by the title and promise of this book which purports to show that "by the end of his [Beethoven's] . . . spiritually eventful life he had become a religious composer of a kind without precedent" (p.4). Mellers' method is to present musical analyses of Beethoven's works and draw from them philosophical and theological conclusions. The author warns that this is a risky undertaking, and he is right. The book is not persuasive.

Mellers' thesis is that Beethoven sought throughout his life a lyric consummation, a "Hidden Song" in Mellers' terminology, and that Beethoven achieved this apotheosis in some of the late works. The author devotes almost three-quarters of the book to analyses of selected piano sonatas, and he examines them in the context of where each fits on the path to the ideal "Hidden Song," which Mellers equates with the "Voice of God." The remainder of the book

includes an extended chapter on the *Missa Solemnis* and brief essays on *Fidelio*, the *Diabelli Variations*, the shorter late piano works, and the problems of rendering Beethoven's piano music today.

Mellers' analyses, originally given to his classes as oral presentations from the piano, leave much to be desired. They read like a travelogue; the author comments on the scenery as it interests him, occasionally stopping to assess its significance, but more often not. The prose varies from florid to pedantic; the cataloging of key changes in the late sonatas surpasses all reason. Other analytical studies are far superior. Mellers generally neglects any historical references and consistently avoids the insights provided by the sketches—two perspectives which make Martin Cooper's analyses of the late works so effective (*Beethoven: The Last Decade 1817-1827*). The reader easily gets lost in Mellers' analytical writing for lack of sufficient measure numbers, a problem that does not occur with the precise formats of Eric Blom or Donald Francis Tovey. The prose is fre-

## POSTSCRIPT

Bach endowed the number 21 with a special meaning. Nevertheless, as I mean to show in a future article, he adhered to a historical tradition of a theme with twenty variations.

In the field of architecture, a parallel is to be found in the Long Room of Trinity College at Dublin, Ireland. It is one of the loveliest library reading rooms in Europe. The interior displays twenty-one bays over the length and a three-part division over the breadth. This library building was completed in 1732 according to designs by the architect Thomas Burgh. He orientated himself on Christopher Wren's design for the no less famous library of Trinity College, Cambridge, England, which was completed in 1699. This reading room has only thirteen bays over the length. The Dublin authorities wanted to supercede the Cambridge building "in size and in grandeur."<sup>55</sup> The number following 13 in the Fibonacci series is 21; this seems to be the logical choice for an extension.

The *Passacaglia* occupies an isolated place in Bach's oeuvre.<sup>56</sup> The nature of this form is particularly suited to an unusual compositional plan and to the assimilation of numbers. Another unique facet of the *Passacaglia* is its combination with the Lord's Prayer; neither subject was ever again used by Bach. The hymn *Vater Unser* appears in the *Johannes Passion*, chorale 9, where the tune is set with its fourth stanza, and again in the *Vierstimmige Choräle* BWV 416, where it is set with its first stanza. The same melody, to which other words are set, figures in cantatas 90, 101 and 102, and indeed, it is the subject of various chorale preludes for organ. But the chorale tune, together with the text which Luther wrote for it, has not served as the departure point for, shall we say, a cantata or a motet. One may conclude that the assimilation of the Lord's Prayer into the *Passacaglia* occupied Bach so fully and allowed him to say so much that he felt no compulsion to return to these subjects.

## NOTES

<sup>34</sup> "Unsre musicalische Disposition ist von der rhetorischen Einrichtung einer blossen Rede nur allein in dem Vorwurf, Gegenstande oder Objecto unterschieden: dannhero hat sie eben diejenigen sechs Stücke zu beobachten, die einem Redner vorgeschrieben werden, nemlich den Eingang, Bericht, Antrag, die Bekräftigung, Wiederlegung und den Schluss, Exordium, Narratio, Propositio, Confirmatio, Confutatio & Peroratio."

<sup>35</sup> H. R. Hahnloser. *Villard de Honnecourt*. Kritische Gesamtausgabe des Bauhüttenbuches ms.fr.19093 der Pariser Nationalbibliothek, 2.Aufl. Graz 1972.

<sup>36</sup> The mirror 21-12 is in turn reflected in the proportion of the variation section to the entire *Passacaglia*, 12:21 (with a tolerance of 0.07%, possibly intentional.)

<sup>37</sup> Indeed, *Musicalische Paradoxal-Discourse*, is not among the books in Bach's library listed in the inventory of his estate. Under Cap. XII only religious books are included—no music books, cantata texts or the like (see: Hans Preusz, "Bachs Bibliothek," in: *Zahn-Festschrift*, Leipzig (1) (1928). Also the soon to be published *Untersuchung zu Bachs Bibliothek* by Leaver-Trautmann-Wilhelmi omits the book from Bach's possessions (communication of Dr. Renate Steiger, Heidelberg). It is quite possible that *Musicalische Paradoxal-Discourse* and other books passed into other hands before the inventory or even during Bach's lifetime.

<sup>38</sup> The situation is described in Lohmann A, pp. VIII-IX, XX-XXIII; and in Lohmann B, pp. 109-111.

<sup>39</sup> *Neue Bach-Ausgabe*, Kassel, Leipzig 1978, Kritischer Bericht zu Serie IV, Band 5 and 6 von Dietrich Kilian, Teilband 1, pp. 180-183. Here the important relationship between the ABB and the "Möllersche Handschrift" is also discussed.

<sup>40</sup> Hans-Joachim Schulze, "Studien zur Bachüberlieferung im 18. Jahrhundert," dissertation, Rostock 1978, not yet published.

<sup>41</sup> Lohmann A, pp. XX-XXI.

<sup>42</sup> Lohmann A, p. VIII.

<sup>43</sup> Bach submitted the plan for the enlargement in February, 1708. See: *Neue Bach-Ausgabe*, Kassel, Leipzig, 1963, *Bach-Dokumente* 1/83.

<sup>44</sup> Schweitzer, op. cit., pp. 285-286. The passage quoted refers especially to measures 1-105.

<sup>45</sup> Jacobus Klopppers, *Die Interpretation und Wiedergabe der Orgelwerke Bachs*, Frankfurt-am-Main 1966, p. 125. This pronouncement is, by the way, intended for Bach's organ works in general.

<sup>46</sup> Kobayashi has drawn attention to a manuscript bearing the inscription "Passacaglio con Pedal pro Organo Pleno" (Lohmann A, pl. XXII-XXIII); presumably dating from the 18th century. At the beginning of the 19th century it was in the possession of Franz Hauser, who presented it to Ignaz Moscheles. Since 1929 its location has been unknown. As the sole manuscript with the indication "pro organo pleno" it must be seen in proper perspective: it points to merely one of the possibilities of registering the *Passacaglia*.

<sup>47</sup> See: Hans-Heinrich Unger, *Die Beziehungen zwischen Musik und Rhetorik im 16.-18. Jahrhundert*. Würzburg 1941, pp. 112-120.

<sup>48</sup> Samuel Scheidt introduces this word in his *Tabulatura Nova I* to describe how string players take several notes under one bow stroke. He recommends that keyboard players imitate the style.

<sup>49</sup> Spitta, op. cit., pp. 579-580.

<sup>50</sup> Werckmeister, *Harmonologia Musica oder Kurtze Anleitung zur Musicalischen Composition*, Franckfurth und Leipzig 1702, Hildesheim 1970.

<sup>51</sup> R. Dainmann, "Andreas Werckmeister". In *Musik in Geschichte und Gegenwart*, 14, Sp. 476-480.

<sup>52</sup> See: Friedrich Blume, "Dietrich Buxtehude" in: *Musik in Geschichte und Gegenwart*, 2, Sp. 550.

<sup>53</sup> See: Lohmann B, p. 109, Williams, op. cit., p. 255.

<sup>54</sup> Kilian, op. cit., p. 182.

<sup>55</sup> Peter Fox, *Trinity College Library*, Dublin 1982.

<sup>56</sup> The *Chaconne* in the *Partita d moll* BWV 1004 for violin solo is of a different nature.

quently obscure: "In the first movement heroism is tempered, and strengthened, by irony; in these final bars the effect is inverse and complementary, for a comic-pathetic hesitancy is replaced by canonically continuous scales, warmly spaced [sic] on the keyboard" (p. 76). At its worst the style becomes objectionable when Mellers refers to "a hiccupping acciacatura," "sizzling scales," "tipsily syncopated thirds," "pugnacious sforzandi," and "screwed-up rhythm."

The book is neither general nor scholarly. The analyses are too detailed for anyone other than a musician with theory training to appreciate—in fact, as Mellers warns, the reader must have a score in hand. Numerous references appear throughout the book, all without footnotes. Although the author states that the bibliography contains a list of he works quoted in the text, one looks in vain for the reference to Philip Barford's discussion of the *Diabelli Variations* (mentioned on p. 405). There are other unanswered questions. Why does Mellers say that the mystery of the Immortal Beloved remains unsolved (p. 19) without at least referring to Maynard Solomon's generally accepted proof that she was Antonie Brentano (published five years ago in his *Beethov-*

*en*). Why does he think that the three-fold repeats in the Kyrie of the *Missa Solemnis* (p. 300) derive from Masonic influence rather than the trinity? How can a study on Beethoven and religion avoid almost all mention of the last movement of the Ninth Symphony?

In sum, one is left with the uneasy impression that the book is essentially an excuse to publish the author's musical analyses developed over a lifetime of teaching and that his religious approach is a cohesive force rather than a generating one. The extensive treatment accorded the sonatas that have little or no connection with the "Hidden Song" and the omission of the late string quartets, specifically Op. 132 which does, make this suspicion unavoidable. Mellers examines the essentially non-programmatic genre of the piano sonata and asks us to accept melodies he views as transcendent as proof of Beethoven's religiosity. In the case of the *Missa Solemnis* he extends the thesis of the "Hidden Song" to other considerations, such as the Masonic connection, but the proof is not convincing. That Beethoven did develop a spirituality in his later years is generally accepted, but the evidence for it is better sought elsewhere.

Courtney Adams



## Music for Handbells

By Leon Nelson

**Fantasia on Beloved Hymns**, Douglas E. Wagner, Beckenhorst Press, Inc., HB39, \$1.50. (M—)

"Old and beloved" are these three hymns set for four octaves of bells. "Nearer, My God to Thee", "Old-Time Religion", "What A Friend", with a reprise of the first tune, make a lovely arrangement of the familiar. All three pieces are in the same key, but there is enough variety to keep it interesting.

**Passage of Promise**, D. Linda McKenchnie, Beckenhorst Press, Inc., HB33, \$1.50 (for handbell choir, 4 or 5 octaves, and unison choir). (D—)

Here is a lively piece for both bells and voices, although the bell arrangement could be effective by itself. The sacred text has been written appropriately to the particular season (Advent or Lent). The alternate text appearing in italic can be used for secular occasions such as baccalaureates or commencement exercises. A useful piece colorful enough to fit that special service with pomp and flair.

**Bell Rondelle**, Ellen Jane Lorenz, Beckenhorst Press, Inc., HB32-2, \$1.50. (M—)

A very charming setting by a veteran in handbell composition. Here are two contrasting sections for this 3-5 octave piece—a largo movement and a middle march-like allegro that provides a nice segue back to the original largo idea. Not hard, should be a big hit for everyone involved.

**Echo Song**, Orlando di Lasso, transcribed by Douglas E. Wagner, Harold Flammer, Inc., HP5147, \$1.20. (E+)

Here is the 16th century setting for two choirs of handbells, (2 & 3 octaves, or one choir with piano or organ). A lot can be done with double choir material if one is fortunate to have access to another set of bells. The effect, especially from different locations in the room, can be a real treat for the listener. Easy, but effective.

**Sheep May Safely Graze**, (from *Cantata No. 208*, J. S. Bach), Arr. by Douglas

the same as anyone else.

As a retired scientist, research director, and inventor, I can't believe organ builders are content to copy, and copy, and copy. When was the last time something new was introduced into a pipe organ? Electrical stop actions? Electric motor-driven blowers?

Roland W. Brickenkamp  
Potomac, MD

### Speaks For Itself

With regard to Mr. Phelps' article, or should I say advertisement, for Allen, I wanted to comment paragraph by paragraph, as you owe at least that much to all of us who feel betrayed by opportunism. However, on second thought, it is not really worthy of such an effort. The pipe organ still speaks for itself and does not need any binary positive or negative programmed chips to produce air waves that our ears translate to sound.

Let the following suffice:

O' how the mighty have fallen  
From the "King" to an Allen,

E. Wagner, Harold Flammer, Inc., HP5134, \$95. (E+)

The familiar strains of this melody from the baroque are a welcome addition to any repertoire for service or special use. It is an easy arrangement for 3 octaves of bells and should be appreciated by all.

**The Water Is Wide and Other American Folk Tunes**, Arr. by Douglas E. Wagner, Harold Flammer, Inc., HL5135, \$3.95. (E+)

For 3 octaves of bells, these pieces, *The Water Is Wide*, *Wayfaring Stranger*, *He's Gone Away*, *Black Is the Color*, and *'Tis A Gift to Be Simple*, provide together an unusually nice suite, or they could be used individually. They are not hard and can be a nice treat anytime, and especially for the patriotic holidays.

**Rondo for Bells**, B. Wayne Bisbee, Harold Flammer, Inc., HP5146, \$1.20. (M)

This rondo is a well-written piece for only 2 octaves (optional third). There are some nice effects with table dampened passages and there are long eighth note melodic phrases where the bells ring through without dampening. A nice gem for a small choir.

**Suffer the Little Children**, Douglas E. Wagner, Beckenhorst Press, Inc., HB26, \$1.10. (E+)

This is another one of those pieces one can use with the bells and a children's choir, or just plain unison adult voices. The original tune and text is based on the title works; it is a well written piece and could be put to good use in a variety of service situations.

**Psalm for Bells**, Judy Hunnicutt, Agape, Code No. 133; \$1.95. (E+)

Four Psalms are represented here, all brief, fairly easy, with varied rhythms and keys. Title lines are given to each piece, *Psalm 100*, *Psalm 89*, *Psalm 23*, and *Psalm 150*. These, of course, can be used together as a set or separately. There is some good material here for two octaves of bells. Highly recommended.

Parading it as the real McCoy  
(admittedly the third kind),  
It is not much more than an  
expensive toy.  
Of longevity he spoke in essence,  
Not about hi-tech chips built for  
obsolescence,  
But of pipes without the presence  
Of tin, which,  
Whether hammered or not,  
Assure an early demise.  
Conveniently he forgot  
To tell the whole lot.  
Especially forgot to tell  
the seekers  
About the weakest link,  
The speakers.

Albert Neutel,  
Lawrence, KS.

### No Short Memory

As I read Lawrence Phelps' article, I felt a great sadness descend. One of this generation's finest builders spouting such unbelievable rationalizations was

## New Recordings

A Boston Organ Tour. (1) Gigout: Grand Choeur Dialogue; Franck: Prière; Dupré: Carillon. (2) Franck: Fantaisie in A; Bonnal: La Vallée du Béhorléguay, au matin; Guilmant: Finale (Sonata 1). (3) Sweelinck: Balletto del Granduca; Mozart: Fantasia in F Minor, K 594; Bach: Wir glauben all, BWV 740, Prelude & Fugue in C Major, BWV 550. (4) Valente: La Romanesca; Carvalho: Allegro; Pasquini: Partita on La Folia; Buxtehude: Magnificat Primi Toni; Krebs: Prelude & Fugue in C Major. Brian Jones, organist. BKM Associates, 6 Ledgewood Rd., Wilmington, MA 01887. AFKA Digital DS-5001/4 (two discs) \$25.00 postpaid.

Brian Jones has recorded four important organs in the Boston area: (1) E. & G.G. Hook, Op. 322, 1863, Church of the Immaculate Conception, (2) Aeolian-Skinner, Op. 940, 1935, Church of the Advent, (3) C.B. Fisk, 1971, Old West Church, and (4) Frobenius, 1972, First Church, Congregational, Cambridge. Each instrument is significant in its own right, and repertory has been carefully chosen to demonstrate respective strengths. We must confess partiality toward the Hook. Its massively sumptuous, deep-seated sound bears many rehearings. The beautiful flutes of the Fisk organ make the Mozart and Bach chorale preludes good choices. Colorful reeds and a large pedal division make the Frobenius effective in the Buxtehude and Krebs pieces.

Brian Jones is a first-rate performer. Specifications, details of the repertory, and attractive photographs make this album a collector's item.

**Anton Heiller. Complete Organ Works. Vol. 5. Peter Planyavsky, organist. Chorale preludes on tunes from a Danish Hymnbook: O Haupt voll Blut und Wunden, Det hellige kors, Rind nu op I Jesu havn, Min sjael, den Herren love, Sorrig og glaede, Freu dich sehr o meine Seele, Som lilliens hjerte kan holdes i grode, Jesu meine Freude, Praeludium & Fugue in A Major, Partita on Nun komm der Heiden Heiland, Prelude on Verleih uns Frieden gnädiglich. Musica Viva MV 30-1096.**

Anton Heiller was best known as a performer. He was also an active composer, writing for organ, choir, and solo voice. Peter Planyavsky is one of Heiller's native Viennese students and regularly performs his teacher's music. The organ used in this recording is located at St. Paul's Church, Döbling (Vienna). It

was built in 1978 by Gregor Hradetzky.

As a devout Catholic, Heiller's chief interest in composition was music for the liturgy. Organ music for this purpose often took its initial shape as improvisation, later to be polished, notated and published. The 1949 Prelude and Fugue in A Major, on the other hand, has a rather tightly organized syntax and is mildly dissonant.

**Musik der Reformation (Music of the Reformation). Capriccio digital CD 751007/1-3 (three discs). American Lutheran Publicity Bureau, 308 W. 46th Street, New York, NY 10036. \$31.95 postpaid; also available on cassette tapes, same cost.**

This recording is indispensable for anyone interested in music of the early German Reformation ca. 1520-ca. 1540. Repertory includes Gregorian Chant sung in German, early German chorales sung in unison, early Lutheran polyphony, and music for instrumental ensemble. Composers represented are: Johann Walter, Thomas Müntzer, Antoine de Févin, Martin Luther, Georg Froster, Caspar Othmayr, Josquin, Adam Puschman, Benedictus Ducis, Arnold de Bruck, and Ludwig Senfl.

The Dresdner Kreuzchor, the Capella Fidinicia (recorder, viola da gamba, zink, posauone, and dulzian), and Peter Schreier (tenor soloist) collaborated in the recording sessions held in January, 1982, at Dresden's Lucaskirche. An elaborate album insert booklet has photos of performers and recording sessions, a complete list of repertory and performers, and commentary on the early Reformation period.

Performances are uniformly excellent; the fine boy sopranos, especially, are a joy to hear. Notably absent is that "lifeless" quality so often associated with "authentic" recordings. The continuum from chant in Latin to chant in German to early chorale style is a revelation. Also interesting is the continuum from liturgical music to music for private home devotions and music-making.

In this 500th anniversary year of Luther's birth, we may expect other recordings, performances, and commentary of this kind. This particular album, however, sets standards which are unlikely to be surpassed. Our only reservation about the entire album is the English translation of the liner notes which at times borders on incomprehensibility.

Wesley Vos

difficult to stomach. You will do the organ world a great favor if you would reprint Mr. Phelps' article "Thoughts on the Future of the Organ," published in ISO Information, Nr. 1, February 1969. [Please note letter following.—ed—] Surely Mr. Phelps does not believe that the world has such a short memory, as not to catch a denial of what he seemed to state so "sincerely" only 14 years ago!

James M. McEvers,  
Makanda, IL 62958

### Phelps Quoted

In contrast to the article in the March 1983 issue of THE DIAPASON regarding the digital electronic organ, written by my friend Lawrence Phelps, I offer these quotations from a previous article by Mr. Phelps (ISO Information, February, 1969):

I often tell my young voicers, when they

ask how they can tell if they are producing a good sound, that if they think it can be duplicated electronically, it is a bad sound and will not be acceptable . . . Strangely enough, thick, opaque sound is still being produced with new pipes here and there in America. It is only to people to whom this type of tone is still acceptable that electronics seem an admiral substitute, and it is only to those who still produce this kind of tone that electronics offer serious competition.

I should not hesitate to dispel the myth of long, trouble-free service so widely advertised by electronic manufacturers. We are in a position to know because we replace so many electronic instruments with organs.

It seems the electronic inventors are finding it hard to know what to do next . . . Next, they will try tracker action, and maybe even real wind. These pathetic attempts are in themselves admissions of the inadequacy of the electronic attempts, and we should not neglect the opportunity to bring this to the public attention.

Thomas Turner  
Houston, TX

Readers note: The editor welcomes commentary on issues published in THE DIAPASON. Also welcomed are enlightened observations and personal opinions of matters not addressed in these pages. Address letters to: The Editor, The Diapason, 380 Northwest Highway, Des Plaines, IL 60016

## Here & There



Diane Bish, organist of the Coral Ridge Presbyterian Church, Ft. Lauderdale, FL, and guest artist Jerome Hines of the Metropolitan Opera pause for a photo session during the taping of "The Joy of Music", a nationwide television series featuring Ms. Bish as hostess and performer.

The program is sponsored by the Church Music Explosion Foundation of Ft. Lauderdale of which Diane Bish is founder and president.

Ruth Plummer, executive director of Artist Recitals Talent Agency has announced the availability of organist William Charles Beck and String player, Mark Chatfield for duo concert engagements.

Mr. Beck is a three-time winner of the Los Angeles Chapter (A.G.O.) Competition, and has appeared as soloist and accompanist with many nationally-known musical organizations.

Mark Chatfield is the founder of La Chanterelle, an ensemble of baroque string players.

Further information may be obtained from: Artist Recitals, 2525 Hyperion Av., Los Angeles, CA 90027, or call (213) 665-3014.

The annual Festival of Choirs at Crystal Cathedral, Garden Grove, California, was held on June 5. Twelve different groups from the church participated. Frederick Swann directed the combined choirs and was assisted by Richard Unfreid.

William Brice of Knoxville, TN played a recital during an "open house" celebration of the new edifice for the First Church of Christ, Scientist, South Bend, IN. The instrument, built by E.M. Skinner in the 1920's, had been moved from the church's previous building.

According to the *South Bend Tribune*, Brice's recital of Purcell, Bach, Buxtehude, Pachelbel, Haydn and Dupré was played on "the rebuilt Sinner [sic] romantic organ."

Evidently the instrument has rejected all attempts of conversion.

Radio station WCLV-FM, Cleveland, OH, has announced a new monthly schedule of remote, live church broadcasts for that station's "Organ Masterpieces" program which airs each Sunday afternoon at 3:30 pm.

"Organ Masterpieces" features weekly performances of renown organists from around the world with one program per month being devoted to the work of Cleveland-area musicians. Local organists who have been heard on the program include Karel Paukert, Michael Murray, David Gooding, John Ferguson and Judith B. Metz.

A new, nationally distributed series of programs devoted to the organ and its music, produced by Minnesota Public Radio, will be available through the American Public Radio Network to public radio stations across the country, beginning in October.

Initially projected as a 39-week series, *Pipedreams* will focus on live-performance recordings of music from the 17th through the 20th centuries, played by noted artists on American and European instruments. Throughout the series, players, organ builders and composers add their remarks to those of program host Michael Barone.

Programs for the series will be derived from the 1980 and 1982 National Conventions of the American Guild of Organists, the 1982 Haarlem Festival from Holland and the Festival of Flanders in Belgium.

An earlier *Pipedreams* series, distributed two years ago, was heard on 61 stations nationwide, and was well received. The new series will be distributed via satellite to American Public Radio affiliate stations. Information concerning individual stations' plans to carry the program, and specific times and dates can be obtained by contacting local public radio stations.



Philip Hahn has joined the concert management of Artist Recitals Talent Agency.

Mr. Hahn has held teaching positions in the music departments of the University of Northern Iowa and at the University of Illinois (Chicago Circle). He has served as Organist-Choirmaster at the Episcopal Church of St. Paul and the Redeemer, Chicago; and the First United Methodist Church in Waterloo, IA; and as organist at the First Presbyterian Church, San Anselmo, CA.

His Bachelor and Master of Music degrees were obtained at the University of Michigan where he studied with Marilyn



A portrait by John Menihan of the late Harold Gleason was unveiled in the gallery of the Eastman School of Music on April 26, 1983. Present at the unveiling were (left to right): Russell Saunders, Walter Holtkamp, Karen McFarlane, Catharine Crozier (Mrs. Harold Gleason), and David Craighead.

Mason and with Robert Noehren. He received the Doctor of Musical Arts degree from the American Conservatory of Music, Chicago, where he studied with Robert Lodine. Further study has been with Nadia Boulanger and with André Marchal.

Dr. Hahn has been awarded the A.A.G.O. certificate and is currently the Sub Dean of the San Francisco Chapter of the American Guild of Organists. Hahn is an executive committee member for the 1984 National AGO convention.

## Appointments



John Rose has been appointed Senior Organist of St. Joseph's (RC) Cathedral, Hartford, CT. His duties at St. Joseph's will include playing masses for major festival days and diocesan occasions, working with the concert series, and coordinating efforts with the cathedral music director, Peter Harvey, for major events.

Mr. Rose's primary work, however, will continue to be at Trinity College where he has served as College Organist for the past six years. Between the two Hartford posts, Mr. Rose will preside at the two largest organs in the area.

John Rose's association with St. Joseph's Cathedral began in 1977 when he recorded there for the first time.

David Lowry, college organist of Winthrop College since 1965, has been named professor of music, having served until this time as associate professor. He has been responsible for designing and chairing a new program at Winthrop leading to a bachelor of music degree in church music.

In addition to his duties at Winthrop College, Dr. Lowry is the director of music at the Church of Our Saviour, Rock Hill, SC, and the conductor of an area orchestra and choral society. He is a member of the board of directors of the Royal School of Church Music (RSCM) in America and is the current chairman of the Royal School's Training Courses Committee.

Lowry earned his bachelor of music degree at Baldwin-Wallace College, his master of sacred music degree at Union Theological Seminary School of Sacred Music, and his doctorate of musical arts at North Texas State University.





## Appointments

**Peter V. Picerno** has been appointed organist-choirmaster at Idlewild Presbyterian Church, Memphis, TN. He succeeds Billy J. Christian, who had held this position for 25 years.

Dr. Picerno holds degrees in organ and musicology from the University of Kansas, the University of Oregon, and Oberlin College Conservatory. In 1976 he was awarded a Fulbright Grant for study in Italy.

Picerno has held church positions in Topeka, KS, Manhattan, KS, and at the American Episcopal Church in Rome, Italy. He has also served as chairman of the Professional Concerns Committee for the Greater Kansas City Chapter of the American Guild of Organists.

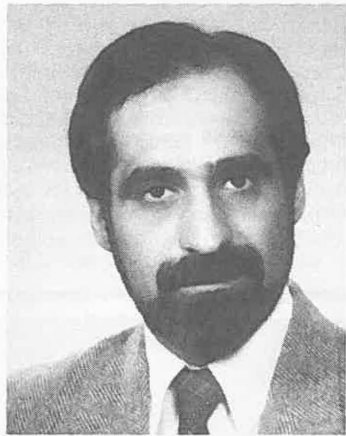

**Melvin West** has been appointed Minister of Music at the Westminster Presbyterian Church in Lincoln, NE, where he will administer the entire music program including ten choirs—choral, bell and brass. His specific responsibilities include that of organist and conductor of the Lincoln Westminster and Adult Handbell choirs.

Mr. West's previous career has centered in college teaching at Atlantic Union College in Massachusetts, and at Walla Walla College in Washington. In 1977 he became the first full-time organist at the Seventh-day Adventist Church at Kettering, OH.

Dr. West's organ study has been with Claire Coci, Leslie Spelman and George Faxon.



**William K. Meyer** has been appointed Minister of Music at the First United Methodist Church, Westmont, IL, where he will institute a graded choir program and establish an organ and choral series.

Mr. Meyer, who is on the extension faculty of the Sherwood School of Music, Chicago, is a graduate of the American Conservatory of Music where he was a student of the late Edward Eigen-schenk. Additional study by Mr. Meyer was with Malcolm D. Benson at Wheaton College, Wheaton, IL.



**Darryl Nixon** has been appointed Church Musician of St. Andrew's-Wesley Church, Vancouver, B.C. Mr. Nixon who is a recitalist and recording artist, is the recipient of a First Prize (with distinction) Award from the Geneva (Switzerland) Conservatory, and the Henri Broilette Prize for outstanding performance in organ.

He is a former student of Lionel Rogg and has also studied harpsichord with Christianne Jaccotte and Gordon Murray. Other studies in choral and organ technique have been with Donald Hadfield and Lawrence Ritchey.



**Gerald F. McGee** has been appointed to a two-year term as Municipal Organist for the City of Portland, ME. In his new position, Mr. McGee will pre-

side at a four-manual, eight-division Austin organ built in 1912 and donated to the city by Cyrus H.K. Curtis in memory of his friend, Hermann Kotzschmar, a composer and organist.

In addition to regular performances by Mr. McGee, he will coordinate a recital series which is to invite a number of well-known organists to the Portland instrument.

Mr. McGee received his education from Westminster College, New Wilmington, PA; the School of Sacred Music, Union Theological Seminary; and Washington University, St. Louis. His study has been with Raymond Ocock, Stanley Tagg, Donald McDonald, Howard Kelsey, and Anton Heiller.

McGee is the Chairman of the Music Commission for the Episcopal Diocese of Maine, and the organist at the Cathedral Church of St. Luke, Portland. He has held teaching positions at the Dana School of Music, Youngstown, State University, the University of Tampa, and was Chairman of the Music Department at Mary Institute in St. Louis.

**John A. Ferguson**, formerly music director and organist at Central Lutheran Church, Minneapolis, MN has been appointed to the faculty of St. Olaf College, Northfield, where he will direct the church music program. Dr. Ferguson received the BMus from Oberlin College, and the MA and DMA from Kent State University and the Eastman School of Music.

He is the author of several books and numerous articles and reviews. He was music editor of the 1975 United Church of Christ hymnal. Currently chairman of the national committee for church music of the American Choral Directors Association, he is also a member of the national committee on professional education of the AGO.



## Honored



In celebration of the 50th anniversary of Jason H. Tickton as Organist at Temple Beth El, Michigan's oldest Jewish Congregation, a festive weekend of music marked this special occasion.

On Friday, May 13th, 1983, a program of contemporary music by American Jewish composers featured *The Burning Bush* by Herman Berlinski, *Devotion*, by Cindi Rosner Kelly, for

woodwinds and piano, Julius Chajes' *Trio* for strings and piano, and Chajes' *Prayer*, composed for the organ. Additional works featured other instrumentalists and four area choirs under the direction of Mrs. Jason Tickton.

On Sunday, May 15th, 1983, Mendelssohn's oratorio, *Elijah* was performed in Dr. Tickton's honor as a part of the Bushnell Performing Arts Series. The Bushnell Congregational Church Choir, the Kenneth Jewell Chorale, and members of the Detroit Symphony Orchestra were directed by organist Ray Ferguson. The Metropolitan Opera's William Warfield was the featured bass-baritone.

In addition to his work at Beth El Congregation, Dr. Tickton has been a faculty member of the Wayne State University for the past 46 years, a prolific composer of Jewish liturgical music, an author of many articles on Jewish music, and an organ recitalist. His many awards and recognitions include the "President's Award for Excellence in Teaching."

In recognition of Dr. Tickton's half-century of service to Beth El Congregation, The Ticktons were given a three-week vacation to Israel and London.



Philip Brunelle (right) receives Kodaly Award from Hungarian dignitaries.

Philip Brunelle received the Kodaly Award in ceremonies at the Hungarian Mission in New York City, April 22nd. To honor the centenary of Zoltan Kodaly, the Hungarian government observed a special occasion in honor of 20 musicians from all parts of the world who have contributed significantly to the performance of Kodaly's music. Of ten Americans honored, Philip Brunelle was the only church musician.

## Honored

The Board of Trustees of Southern Methodist University, Dallas, has named **Robert Anderson** a Distinguished Professor. Under the guidelines established by the board, the designees are "outstanding teachers/scholars who meet the most rigorous scrutiny of academic achievement" and "whose stature and contributions clearly merit special recognition."

As a Distinguished Professor, Dr. Anderson will receive an annual salary supplement for discretionary professional and creative development purposes.

**James Litton**, organist and director of music of St. Bartholomew's Church, New York City, was made a Fellow of the Royal School of Church Music (RSCM) during ceremonies following the June 28th RSCM Council Meeting at Addington Palace, the international center of the RSCM, in Croydon, England.

The FRSCM diploma was presented to Litton by the Bishop of Bath and Wells, Council Chairman, and by the Director of the RSCM, Dr. Lionel Dakers.

Litton becomes the third individual in the United States to receive the Fellowship diploma, the other two being Gerre Hancock and Alec Wyton.



## Winners

The College-Conservatory of Music of the University of Cincinnati has announced the winners of the 1983 Strader Organ Scholarship competition. The first, second, and third prize winners in the graduate category are awarded cash prizes as well as full scholarship to the college.

The first-prize winner is Henry McDowell of Durham, NC. Mr. McDowell received the Bachelor of Music degree in organ performance from

North Carolina School of the Arts.

The second prize was won by Brian Luckner of Massillon, OH. Mr. Luckner is a repeat winner of this competition who received his Masters degree from the College-Conservatory this year. He will use his award to continue advanced graduate studies at the school.

Darryl Roland of Palmyra, PA is the third-prize winner. Mr. Roland received his BA in Organ Performance at Leba-

non Valley College in Annapolis, PA.

Judges for the competition were Roberta Gary and David Mulbury, both of the College-Conservatory's Organ Department. The cash prizes are provided by Mr. and Mrs. John W. Strader, benefactors of the school, and organ enthusiasts. The Straders have supported the schools' Organ Guest Artist series and have contributed to the rebuilding, acquisition, and restoration of organs at the school.



Finalists and winners in the 1982 organ competition of the First Presbyterian Church of Ottumwa, IA were (left to right): Mark Steinbach, First Place; Brian Williams; Deborah Friauff, Second Place; Lynn Trapp; and William Crouch. Competition Judge Grigg Fountain is shown in the photo to the right.



## Coming Events

The First Presbyterian Church of Fort Wayne, IN has announced that the 25th Annual National Organ Playing Competition, sponsored by the church, will be held on Saturday, March 10, 1984. All organists who have not reached their 35th birthday by that date are eligible to compete.

Interested applicants are required to submit a tape recording no later than January 25, 1984, to be entered in the preliminary judging. Required compositions to be submitted by tape will include the complete *Trio Sonata No. 6*

in G Major by J.S. Bach, and a work by a composer born between 1750 and 1902.

Eight finalists will be chosen by a panel of judges, and will be required to play an additional composition by a composer born no earlier than 1903. A separate panel of prominent musicians will complete the final judging.

The winner of the competition will appear on the church's recital series, and will receive a cash prize of \$600. The first runner-up will receive \$400, and the remaining finalists will receive travel subsidizations of up to \$200 each.

The Fort Wayne Organ Playing

Competition has grown over the past 24 years to attract international recognition. Virtually every state of the Union and numerous foreign countries and Canadian provinces have been represented in the competition since its inception.

Complete details of the competition as well as entrance forms may be obtained by writing: National Organ Playing Competition, First Presbyterian Church, 300 West Wayne Street, Fort Wayne, IN 46802.

The 1983 Organ Conference at the University of Nebraska-Lincoln is scheduled for October 13-15. Focus of

this year's conference will be Max Regier, his contemporaries, and particularly the tradition carried on by students of Karl Straube and their subsequent students. Participants include Heinrich Fleischer, Nancy Lancaster, and Kurt Lueders. For more information: Dr. George Ritchie, School of Music, University of Nebraska-Lincoln, Lincoln, NE 68588.



<b>Organ Leathers</b>
Quality Skins for Every Need
<b>COLKIT MFG. Co.</b>
252 Fillmore Avenue Tonawanda, NY 14150
(716) 692-7791
Sample card sent on request.

since 1845

**Rieger**

Rieger Organs  
A-6858 Schwarzach Austria

**KOPPEJAN**  
pipe organs  
Tracker-organ builder  
new organs and restoration

Chilliwack, B C  
48223 Yale Rd E  
Canada V2P 6H4 Phone (604) 792-1623

**Delaware ORGAN CO.**

Villa Maria College  
Buffalo, New York

**252 FILLMORE AVENUE**  
**TONAWANDA, NEW YORK 14150**

Member: APOBA  
**(716) 692-7791**

**Walcker**  
Organ Builders

Tracker Organs • Organ Parts • Organ Pipes

1780—200 Years—1980  
Tradition and Progress

D-7157 Murrhardt-Hausen 10  
Phone: 07192/8006



Arno Schönstedt plays  
**Hugo Distler**  
**Complete Organ Work**  
4 records, documentary brochure  
Pape Records — TELDEC pressing  
\$ 39.00

Pape  
**Organs in America**  
Vol. 1  
204 pages, 95 photos, \$ 34.00

Pape  
**The Tracker Organ Revival**  
in America  
488 pages, 272 photos, \$ 48.00

Pape  
**A Little Organ Lexicon**  
English-German, German-English  
40 pages, \$ 5.00

Postpaid  
Make checks payable to Uwe Pape  
**PAPE VERLAG BERLIN**  
8231 Ravere Street  
Rockford, Ill. 61111





recital by Ann Labounsky and William Hays.

Jacqueline Marchal-Englert, Marchal's daughter, will be a special guest of honor at this event.

Duquesne University will sponsor "The Art of André Marchal: a Symposium on his Music and Pedagogy" on October 21 and 22. Sessions are to include master classes on style, articulation, registration and pedagogy. Also featured will be a panel discussion and a

Details and application forms for the Ruth and Clarence Mader Memorial National Organ-Playing Competition may be obtained from the Ruth and Clarence Mader Memorial Scholarship Fund, P.O. Box 571, Pasadena, CA 91102. The deadline for receiving tapes

and application forms is February 1, 1984 for the competition which is to be held on Friday, March 30th, 1984.

Christ Church, Cincinnati, OH celebrated the completion of its renovated nave with a banner year of 35 concerts and special musical services including the Berlioz *Te Deum*.

The church's 3-manual, 71-rank Holtkamp organ now speaks into a lively environment with three seconds of reverberation.

## Nunc Dimittis

James B. Wallace, Professor of Organ and former Dean of the University of Michigan School of Music, died on July 12, 1983. He was 67 years old.

A native of Westminster, SC, James Wallace received the Bachelor of Arts degree from the University of Mississippi; the Bachelor of Music degree from Westminster Choir College, and the Master of Music degree from the University of Michigan.

He was awarded an honorary Doctor of Music degree from Hillsdale College in Michigan in 1961, and an honorary Doctor of Fine Arts Degree from Westminster Choir College in 1967.

Wallace had been a member of the Michigan faculty since 1948, having been originally appointed to the Department of Music Literature. He became a member of the Department of Organ in 1970, and served at various times as Secretary, Assistant Dean, and Dean of the School of Music.

Prior to having joined the Michigan faculty, Wallace was Dean of Music at Belhaven College in Jackson, MS.

In addition to his work as a teacher and administrator, James Wallace had served as Organist and Director of Music at Park Avenue Presbyterian Church, New York City, Old York Road Presbyterian Church, Philadelphia, and the First Presbyterian Church in Ann Arbor, MI. In 1938 he was the conductor of the Philadelphia Bach Choral Society.

Donald C. Gilley of Annapolis, MD, died unexpectedly on May 11, 1983. He was retired from the position of Director of Musical Activities at the U.S. Naval Academy. Born in Stoughton, WI on June 4, 1904, he studied for two years at Beloit College before transferring to the Oberlin Conservatory of Music from which he graduated in 1928. He later obtained the Mus.M. degree from Cincinnati Conservatory, studied privately

with E. Power Biggs, and did graduate study in composition at Peabody Conservatory and Catholic University. He also acquired the A.A.G.O. and Ch.M. certificates from the American Guild of Organists, having taken the first Ch.M. examination which was given.

From 1928-33 Donald Gilley was head of the music department at Earlham College where he established the first major in music, and from 1933-38 he was head of the organ department at Butler University and the Jordan Conservatory of Music. Subsequently, he was Minister of Music at Wesley United Methodist Church in Worcester, MA.

In 1942 he joined the faculty of the Navy Chaplain's School in Williamsburg, VA, where he directed a weekly national radio broadcast entitled "The Navy Sings", played the organ and directed the choir at daily services in Wren Chapel, and gave organ recitals in Bruton Parish Church. From there he was recruited to become Organist and Choirmaster at the U.S. Naval Academy on January 10, 1944. At that time there was a 135-man Chapel Choir which through the years performed at all Chapel services for the brigade of midshipmen, at the White House, on network radio and television, in motion pictures, at churches throughout the United States, and at an Easter Service in the Hollywood Bowl.

In 1950 Gilley organized a 160-man Antiphonal Choir which joined the Chapel Choir in singing at all weekly services in the Chapel and performed in numerous churches including the National Cathedral, St. Patrick's Cathedral, Temple Emmanuel, and the Fifth Avenue Presbyterian Church. At about the same time, Mr. Gilley became the first director of the Midshipmen's Glee Club, an organization that subsequently achieved prominence through annual tours, television appearances, and numerous other public concerns.

He was best known, perhaps, in the

Annapolis area for the annual presentation of Handel's "Messiah" by the choirs of the Naval Academy and of Hood College. He conducted this work for 25 years until his retirement, performing before capacity crowds in the Naval Academy Chapel. He also played many recitals on the Academy organ, much of which he designed, and composed numerous pieces for organ and orchestra. His composition for organ and strings was performed at the American Music Festival at the National Gallery of Art.

After almost 29 years, Donald Gilley retired on October 1, 1972, from a position which he considered a privilege and a challenge—emotionally, spiritually, and professionally. After retirement, he taught organ privately. He was an honorary member of the Naval Academy Alumni Association, and honorary member of the Naval Academy Classes of 1950 and 1973, and an Honorary Chaplain in the U.S. Navy. He held dual memberships in the District of Columbia and Annapolis Chapters of the American Guild of Organists. He had been Dean of the Indianapolis Chapter in the 1930's and Vice-President of the College Music Association, as well as a member of the Hymn Society of America.

Memorial services were held on May 16, 1983, in the Naval Academy Chapel. He is survived by his wife, the former Dorothy Young.

representing today's prestige concert organists

MICHAEL CORZINE  
NICHOLAS DANBY  
RAYMOND DAVELUY  
LYNNE DAVIS  
ROBERTA GARY  
JEAN-LOUIS GIL  
ROBERT GLASGOW  
JEAN GUILLOU  
RICHARD HESCHKE  
AUGUST HUMER  
DAVID HURD  
HUW LEWIS  
ODILE PIERRE  
MCNEIL ROBINSON  
JOHN ROSE  
LARRY SMITH  
HERNDON SPILLMAN  
ERNST-ERICH STENDER  
JOHN CHAPPELL STOWE  
MARIANNE WEBB  
GILLIAN WEIR

THOMAS BROWN

pianist

CHRYSOLITH

harp and flute duo

GIOVANNI De CHIARO

classical guitarist

DON MURO

musical electricity

THOMAS RICHNER

pianist

ROBERT EDWARD SMITH

harpsichordist

phillip truckenbrod

representative for concert artists

Box 14600

Barry Square Station

Hartford, Connecticut 06114

(203) 728-1096

## Goulding & Wood, Inc.

BUILDERS OF FINE ORGANS IN THE AMERICAN CLASSIC STYLE  
INCORPORATING REMOTE-ACTION, SLIDER-PALLET WINDCHESTS.

Known for our renovation work, especially restoration of Aeolian-Skinner organs.

THE AMERICAN REPRESENTATIVE FOR J.W. WALKER & SONS LTD., ENGLAND

These superbly built, mechanical-action instruments of classical Anglo-American tonal design are best suited to the needs of most American congregations.

1506 East Richland Drive

Bloomington, IN 47401

(812) 339-4843

## The Inspirational Sounds of

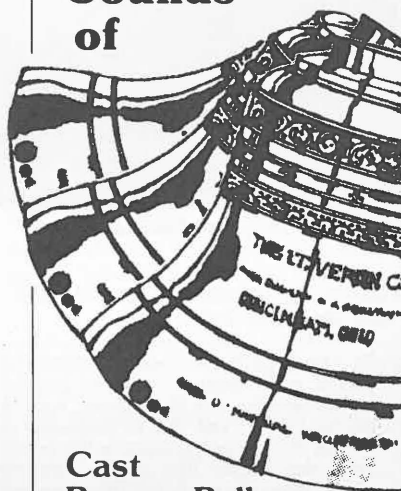

Cast Bronze Bells and Bell Systems.

Renowned for their exquisite sound . . .



2021 Eastern Ave.  
Cincinnati, Ohio 45202  
(513) 221-8400

# You can now order article reprints from this publication

University Microfilms International, in cooperation with publishers of this journal, offers a highly convenient Article Reprint Service. Single articles or complete issues can now be obtained in their original size (up to 8 1/2 x 11 inches). For more information please complete and mail the coupon below.

## ARTICLE REPRINT SERVICE

University Microfilms International

YES! I would like to know more about the Article Reprint Service. Please send me full details on how I can order.

Please include catalogue of available titles.

Name \_\_\_\_\_ Title \_\_\_\_\_

Institution/Company \_\_\_\_\_

Department \_\_\_\_\_

Address \_\_\_\_\_

City \_\_\_\_\_ State \_\_\_\_\_ Zip \_\_\_\_\_

Mail to: University Microfilms International  
Article Reprint Service  
300 North Zeeb Road  
Ann Arbor, Michigan 48106

## Kimber-Allen, Inc.

Box 4058, C.R.S.

Johnson City, TN 37601

615-282-4473

Quality Organ Components

# Some Literary References to the Harpsichord and Clavichord: 1855-1923

Larry Palmer

While it is true that harpsichords and clavichords lost favor as the reigning home keyboard instruments, falling rapidly into obscurity and near-extinction after 1810, it is also true that someone, somewhere, throughout a century of "sleeping-beauty" status for historic instruments kept them alive by featuring them in an occasional concert of "antient musick" or by writing of them in various poems, diaries, journals, or novels. In these writings one may note a progression from nostalgia-producing curiosity to a reawakened interest in the musical capabilities of the instruments as the gradual revival of performances on harpsichord and clavichord became more accepted in the early years of the twentieth century.

The English poet Robert Browning (1812-1889) assured the immortality of the nearly-forgotten Italian composer Baldassare Galuppi (1706-1785) when he published "A Toccata of Galuppi's" in the two-volume *opus* "Men and Women" in 1855. Browning wrote,

"O they praised you, I dare say!  
Brave Galuppi! that was music! good alike  
at grave or gay!  
I can always leave off talking when I hear  
a master play!  
. . . . While you sat and played Toccatas,  
stately at the clavichord. . . ."

Although Browning, like so many authors, may have been confused as to which of the older instruments his master played, his use of this image evoked an earlier time in a way no other line of his poem was quite able to do.

Memoirs and diaries provided several references to the harpsichord during the second half of the nineteenth century. Eduard Devrient (1801-1877), in *Meine Erinnerungen an Felix Mendelssohn-Bartholdy* (Leipzig, 1869; English translation by Natalia Macfarren, 1869), described the events which lead to the famous performance of Bach's *St. Matthew Passion* conducted by Mendelssohn in 1829. To obtain permission to do this work with the Berlin Singakademie, the two young men visited Karl Zelter, the conductor of the group (and Mendelssohn's teacher). Devrient related,

We knocked. A loud, rough voice bid us come in. We found the old giant in a thick cloud of smoke, his long pipe in his mouth, sitting at his old two-manual harpsichord. The quill pen he used in writing was in his hand, a sheet of music paper before him. . . .

An interesting and revealing correlation—harpsichord and quill pen, both symbolic of a past age!

In quite a different vein there is a passing reference to the harpsichord in the *Diaries* of the Rev. Francis Kilvert (1840-1879), an English curate in the country near the Welsh border. *Kilvert's Diary* is one of the most delightful such works to be encountered in the language—an unaffected, buoyant, observant account of daily life in rural English. Under date of Wednesday, 26 October 1870, Kilvert noted,

Carrie Gore let me in to the Mill kitchen through the meal room and loft over the machinery; and there was Mrs. Gore making up the bread into loaves and putting them into the oven. Good-natured nice Carrie, with her brown hair arranged in a bush around her jolly broad open frank face, and her fine lusty arms bare, entertained me by playing on the jingling old harpsichord, sitting very stiff and straight and upright to the work with her chair drawn in as near as possible to the keyboard so that she was obliged to lean a little back quite stiff. She played some hymn tunes correctly, but what I admired most was her good nature, good breeding and perfect manners in sitting down to play directly she was asked. . . .

A professional musician who did a great deal to keep the sound of the harpsichord known in the nineteenth century was the pianist Ignaz Moscheles (1794-1870) whose life was chronicled by his widow Charlotte (*The Life of Moscheles, with Selections from his Diaries and Correspondence*; translated by A. D. Coleridge, London, 1873). In

was the German-born New Haven piano dealer, Morris Steinert (1831-1912) whose *Reminiscences* were published by Putnam's in 1900. In this absorbing volume Steinert told of his experiences in searching for, and finding, the clavichord on which he played as a boy in Scheinfeld, Bavaria, and of his subsequent adventures as he searched



Rainer Maria Rilke and Wanda Landowska

chapter 19, concerning the year 1837, Mrs. Moscheles wrote

On three successive occasions Moscheles played some music of Scarlatti and his contemporaries on a harpsichord, built in the year 1771, and still in possession of Messrs. Broadwood. Externally the instrument was shaped like an old Viennese piano. When the cover was lifted, one saw a contrivance somewhat in the shape of a Venetian blind, which, like the shutter covering the swell part of the organ, was acted upon by the pedals—by using this, greater sonority was given to the tone, which otherwise, was rather thin, and less agreeable. Moscheles gave much attention to the invention, and turned it to good account. The upper and lower keyboards of the instrument were evidently intended for the rendering of such passages of Scarlatti and other masters as on modern pianos require constant crossing of the hands; and one row of keys being connected with two, and the other with three strings, certain shades are produced in the quality of the sound.

An influential figure in the return of the harpsichord to the American scene

throughout Germany and Austria for further examples of early keyboard instruments. Steinert found a notable group of antiques which he shipped to America, eventually restored, and then exhibited in various cities (among them Chicago, for the Columbian Exposition of 1893 and Washington, D.C., at the Smithsonian Institution), before leaving them to Yale University where they form the basis for that school's fine collection of early instruments.

The American music critic and author James Huneker (1860-1921) included "The Haunted Harpsichord" in a volume of short stories titled *Visionaries* (1900). Subtitled "in the style of mock-medieval fiction" it might better be called a "Gothic" tale. In *précis*:

Two adventurers, chasing a fugitive, stop to rest their horses and themselves at an Inn, reputed to be haunted: it had once belonged to a duchess "crazy for music" who had invited the Chevalier Gluck to come down from Paris to play "his wonderful tunes on the beautiful harpsichord in the great salon." Of

course the instrument is heard again during the night, but the music seems to be an anachronistic tune from *Pagliacci*! Eventually the travellers (music critics on a lark, no doubt) discover the trick that has been played on them: their quarry has been at the Inn with them. They take him prisoner, return him to the Parisian lady who had hired them, whereupon she greets him with words, "So you tried to escape? . . . Go, let the servants put you to work in the large music room first. Begin with the grands, then follow with the uprights." The story ends with this paragraph

We had indeed reason to feel flattered at the success of the dangerous expedition. Had we not captured, more by sheer good luck than strategy, the only piano-tuner in mediaeval France?

Poets, too, sometimes mentioned the harpsichord, especially as a symbol of a vanished era. Arthur Symons (1865-1945) dedicated his "On an Air of Rambeau" to Arnold Dolmetsch, the prime mover of the early music movement in England. Symons' poem, which appeared in *The Athenaeum* for February 19, 1898, breathes the mauve and rarified air of the *fin de siècle*:

A melancholy of desire of ancient things  
Floats like a faded perfume out of the  
wires;  
Pallid lovers, what unforgotten desires,  
Whispered once, are retold in your whis-  
perings?

. . . It is the melancholy of ancient death  
The harpsichord dreams of, sighing in the  
room.

In a somewhat similar mood Rainer Maria Rilke (1875-1926) wrote in his *Last Evening (Letzter Abend)* from *New Poems*:

And night and distant travel; for the train  
Of the whole army swept along the park.  
He looked up from the harpsichord again  
and played and glanced at her without  
remark. . . .

(Paris, June 1906)

Rilke might have become familiar with the sound of the harpsichord through the concerts of Elodie Dolmetsch, divorced from Arnold in the early years of the century. Elodie took the family Kirkman harpsichord which she received as part of her settlement, went off to the continent, and, according to Dolmetsch's next wife, Mabel, "thenceforward for several seasons she made a success with her harpsichord playing in Paris."<sup>1</sup> More likely it was the certain impression made on the poet by young Wanda Landowska who had eloped to Paris in 1900, where she made quite a name for herself by introducing the harpsichord to various well-known figures, including the sculptor Auguste Rodin, for whom Rilke served as secretary for a time. A fine photograph of the young Polish harpsichordist playing for the poet in her Paris apartment documents their friendship!<sup>2</sup>

*Sword Blades and Poppy Seed* appeared in 1914, the second volume of poetry published by American author Amy Lowell (1874-1925). "A Lady" begins with these lines,

You are beautiful and faded  
Like an old tune  
Played upon a harpsichord;  
Or like the sun-flooded silks  
Of an eighteenth-century bouidor. . . .

Lowell's poetry abounds with musical references, most of them about the "new music": "Stravinsky's Three Pièces Grotesques for String Quartet," "After Hearing a Waltz by Bartók," "A Violin Sonata of D'Indy." In a later poem, "The Red Lacquer Music Stand,"



she wrote of "sitting to viols or standing up to sing..." but she did not repeat her harpsichord reference again.

Thomas Hardy (1840-1928) used many musical images in his large body of poetry. Often he referred to psalm tunes or other church music, or to the violin of the village musician—images made vivid to him in his childhood. At least twice he refers to the harpsichord, both times in poems appearing in the collection *Late Lyrics and Earlier*, published in May 1922.

In *Penance* Hardy wrote, "Why do you sit, O pale thin man, At the end of the room. By that harpsichord, built on the quaint old plan?" And in a "Phantasy in a Museum of Musical Instruments," *Haunting Fingers*, Hardy allowed viols, cello, drum, shawm, lyre, and harpsichord to speak of past executives:

And they felt past handlers clutch them,  
Though none was in the room,  
Old players' dead fingers touch them,  
Shrunk in the tomb.

... And they felt old muscles travel  
Over their tense contours  
And with long skill unravel  
Cunningest scores.

The tender pat  
Of her aery finger-tips  
Upon me daily—I rejoiced thereat!  
(Thuswise a harpsichord, as 'twere from  
dampened lips).

... Thus they, till each past player  
Stroked thinner and more thin,  
And the morning sky grew grayer  
And day crawled in.

Thus far the harpsichord had been treated in literature (as in life) as a relic, a curiosity, a remnant from the past. It remained for a somewhat unlikely source to give the instrument its due. In the altogether remarkable, entertaining, yet erudite mystery novel *Whose Body?* Dorothy L. Sayers (1893-1957) introduced one of detective fiction's most endearing figures for the first time: Lord Peter Wimsey. In this novel published in 1923, the following passage heralds a more favorable view of the harpsichord, one still struggling to emerge, in some quarters, in these latter decades of the twentieth century!

Lord Peter finished a Scarlatti Sonata, and sat looking thoughtfully at his own hands...

That's a wonderful instrument, said Parker.

It ain't so bad, said Lord Peter, 'but Scarlatti wants a harpsichord. Piano's too modern—all thrills and overtones...

In this, as in so many ways, Lord Peter displayed his superior intelligence!<sup>3</sup>

#### NOTES

<sup>1</sup>Mabel Dolmetsch, *Personal Recollections of Arnold Dolmetsch*, London, 1957; pp. 42-43.

<sup>2</sup>Photograph provided to the author by Mrs. Putnam Aldrich (Madeleine Monjon), who was secretary to Wanda Landowska from 1927 until 1931.

<sup>3</sup>In a later novel, *Gaudy Night* (1936), Sayers has Lord Peter Wimsey wondering "... whether that spinet's in order;" then he "played first a minuet from a Bach suite and then a gigue, before striking into the air of *Greensleeves*." (pp. 322-323).

#### SOURCES

Browning: Quoted in *British Poetry and Prose* (ed. Lieder, Lovett, Root); New York, 1928; pp. 1105-1106.

Devrient: Quoted in *The Bach Reader* (ed. David and Mendel); New York, 1945; p. 381.

Kilvert: *Selections from the Diary of the Rev. Francis Kilvert* (ed. William Plomer); London, 1938-1940; p. 255.

Moscheles: *Life of Moscheles* by Charlotte Moscheles; London, 1873; pp. 236-237.

Steinert: *Reminiscences of Morris Steinert* (compiled by Jane Marlin); New York, 1900; pp. 195-229.

Huneker: *Visionaries*; New York, 1900; pp. 188-202.

Symons: *The Athenaeum* no. 3669 (February 19, 1898), p. 247.

Rilke: *New Poems 1907-1908* (translated by J. B. Leishman); New York, 1964; pp. 112-113.

Lowell: *The Complete Poetical Works* (introduction by Louis Untermeyer); Boston, 1955; page 73.

Hardy: *The Variorum Edition of the Complete Poems of Thomas Hardy* (ed. James Gibson); New York, 1979; pp. 630, 590-591.

Sayers: *Whose Body? The Singular Adventure of the Man with the Gold Pince-Nez*; London, 1923; p. 44.

## Music for Voices and Organ

By James McCray

### THE CHRISTMAS SEASON:

One of the most common hymns for the Christmas season is "Veni Emmanuel" which in English became, "O Come, O Come, Emmanuel." The music is an ancient unison plainsong later harmonized by some unknown musician. As with all European church music of the twelfth century, it was sung in Latin with the words translated into various languages much later. The use of the word "Israel" is obviously a broad generalization which suggests God's chosen people; thus the stanzas may be interpreted as the Old Testament prophecies being fulfilled in the life and teachings of Christ. Each year this hymn is heard throughout the churches of the world, especially during Advent. Perhaps it, as much as any other single hymn, helps to prepare us for the celebration of Christ's birth.

Preparation for anything important demands careful attention. Even during this "age of burnout" it is essential that we extend the Christmas season because of the needed advance organization; without it there is the strong probability of limited success. For me, I shall be departing for my annual summer vacation in a few days, yet my thoughts on this Saturday in July are on Christmas. The same is true for most of you. Reading this article may jolt you into the realization that now is the time to plan for the season and order the music, or it will be too late.

The more responsibility each of us assumes, the more the yearly calendar is destroyed. Children have an advantage; they are told the proper time to do things. In school and church situations they merely pass through the seasons with some abandon and, in general, fit the calendar process comfortably. Adults, however, are rarely so easily programmed. We almost always stand with feet apart in two calendar worlds; in fact, that is one of the losses of childhood. We cannot take the time to enjoy the moment or the season, because we are already mentally in the future.

Alas! There simply is no other reasonable way. We must blend some parts of the seasons in order to have them achieve some degree of success. Our technological society has stretched us so that we can no longer remain compartmentalized. We are too aware of world events and are not isolated. Therefore, we are learning to adjust to Christmas in July, to planning months and years in advance for special events, to future shock. So, read these Christmas reviews, get out your calendars and count the number of rehearsals until Christmas performances, order your music and then calmly whistle "O Come, O Come Emmanuel" on your way to the swimming pool.

**O Come, O Come Immanuel.** Natalie Sleeth, Unison with descant and keyboard, Choristers Guild, 273, .75 (M).

Sleeth has written a new text and melody so this should not be confused with the familiar hymn mentioned above. Designed for a good children's chorus, the theme is tuneful and very appropriate to young voices. The descant is used in the last half of the setting. The keyboard part is probably more suited to piano than organ, but it is easily adaptable to the organ. This is an excellent Christmas work for children's choirs and recommended to those directors who have a solid ensemble.

**Alleluia (from Fanfares).** Daniel Pinkham, SSATBB and organ, E. C. Schirmer Music Co., 3110, 185 (D).

The organ music is challenging, written on three staves and has a single note sustained by the left foot throughout the entire movement. The right foot, additionally, has a separate line. The majority of the eleven-page setting is in less than six parts with some unison and two-part singing. Only the title word is employed; it is set in long lines, brief rhythmic motives and sometimes divided into syllables for different sections. The choral music is not difficult, but will require a good ensemble as they sing above some extended, mildly dissonant organ chords. Sophisticated music for advanced choirs.

Services. The organ writing is not difficult and has sustained chords. This will be best performed by a large choir of experienced singers.

**Christmas Greeting.** Martin How, Unison voices, solos and upper harmony group with organ/piano, Boosey & Hawkes, .50 (E).

This jaunty setting is delightful. It could be performed by young voices or work well with a women's chorus at the junior or senior high school level. The majority is in unison with three-part block chord harmony for the upper group. The solos are easy and quite brief. The music is tonal and will be easily learned.

**Winter's Snow.** Sydney Hodkinson, SATB, alto, soprano and tenor solos, with handbells or optional piano/organ, (M+).

The music moves in 5/8 with a gentleness for all five verses. Full vocal ranges are used for soloists and choir. The mild dissonances never intrude and with the handbells will probably not be noticed. Three full octaves of bells are needed and their music is notated on two staves in piano score format. The music is not unusually difficult but will require a well rehearsed ensemble with a good sense of rhythm. Lovely, sensitive music for advanced church choirs.

**Good News for All.** Eric Routley, for choir, 4 equal voices, congregation, optional organ, brass quintet and timpani, Hinshaw Music Corp., HMC-645, .75 (M)

Routley, who died earlier this year, designed this choral hymn for a festive occasion with massed choirs. He has extensive performance notes which give a variety of performance combinations including using smaller forces. The choral scores include the instrumental parts and a congregation sheet which may be duplicated; they sing stanzas 3, 4 and 5 in unison. Because the choirs are to be in equal unisons, they are all notated in the treble clef; there is a brief choral speaking section. This is a jubilant hymn setting that could be used at Christmas and at other times of the year because of the comprehensiveness of the text.

**Carol of the Nativity.** Robert Wetzler, SATB unaccompanied, Sacred Music Press, S-309, .60 (M-).

The short verses receive a variety of developed treatments. Some may be sung by a small chamber group placed apart from the larger choir. The music is modal and quite charming. The ranges are limited and this could be sung by church or high school choirs. It has a folk-like character and remains soft throughout.

**Lullaby, My Sweet Little Baby.** William Byrd (1543-1623), SSAT unaccompanied, Lawson-Gould Music Publishers, No. 52145, .85 (M+).

Finding Christmas vocal chamber music is sometimes difficult. This madrigal has been edited by Jerome Ries and would be useful to high school and college madrigal singers seeking sixteenth-century literature. The alto part tends to be low and counterpoint is used throughout. The text starts as a lullaby and ends as a tragedy in the killing of the "Holy Innocents" by King Herod.

**Innkeeper's Carol.** Peter Stapleton, SATB, organ and brass, G.I.A. Publications, G-2851, .60 (M-)

This is a fast, lively and very easy carol setting. At times verses are sung by sections or soloists with the chorus having a four-part unaccompanied verse. The bass is optional and merely doubles the given keyboard part. The music is exciting with a high tessitura for the sopranos. The text of the Christmas story is told from the perspective of the innkeeper who gave Mary and Joseph a place to stay. Good for most church choirs.

**Wonderful Peace.** Gustaf Nordqvist (1886-1946), SATB unaccompanied, Walton Music Corp., W 2346, .50 (E).

The original Swedish text is given below the English. There are two homophonic verses having the same music. The simple music moves gently in 6/8 with the choral parts written on two staves in hymn-book style. It would be useful for school or church choirs and could be performed by an average ensemble.

**Magnificat and Nunc Dimittis in D.** George Dyson, SATB and organ, Galaxy Music Corp., 1.5232, .85 (M)

Dyson, a British composer, originally published this setting in 1924. It is typical of early twentieth-century church compositions with chromatic harmonies, wide voice ranges and a practical approach to the choral writing. Each section is exposed. The Magnificat is moderately fast and closes with a Gloria Patri which is different than the Gloria Patri used at the end of the Nunc Dimittis; this is somewhat atypical of Evening

### NEW FOR ORGAN

Wedding Music, edited by David N. Johnson

Volume III 11-9525 6.50  
Volume IV 11-9526 6.50

Also available

Volume I 11-9523 5.50  
Volume II 11-9524 5.50

Preludes on Sacred Harp Tunes, Sam Batt Owens 11-7820 4.50

Festival Piece on the Gregorian Hymn "Ut Queant Laxis", Gerard Farrell For organ, 2 trpts, 2 trom. 11-5970 6.00

Cradling Children in His Arm: A Lullaby for Solo Treble Instrument and Organ, Roger Petrich 11-7680 3.50

**AUGSBURG**  
PUBLISHING HOUSE

426 S. 5TH ST • BOX 1209 • MPLS MN 55440  
3224 BEVERLY BLVD • BOX 57974 • LA CA 90057  
57 E MAIN ST • COLUMBUS OH 43217  
2001 3RD AVE • SEATTLE WA 98121



## A "Modern Portative": Opus 1

Organbuilders beware! Jeffrey Chiplis of Cleveland OH! has discovered, after receiving a degree in Fine Arts from Indiana University (sculpture), that organ building "might be a little more lucrative" than the art profession, yet hold some of the aesthetic rewards which he appreciates in art.

Chiplis has now built his Opus One and Only, a single-manual, mechanical-action instrument of seven keys which play sixteen pipes (twelve of which are interchangeable) on three stops. The foot-operated bellows of the instrument supply approximately 2.75 inches of (very) unsteady wind.

As described in the dedication program for the instrument, this organ is a result of the builders five-year involvement in the pipe organ building industry. The "Modern Portative" is a collection of components which Chiplis salvaged during that time, as well as other parts which were given to him.

Material contributions came from the Holtkamp Organ Company, The First Christian Church of Columbus, IN, the Goulding and Wood Pipe Organ Company, and others. The completed instrument was voiced by Chris Holtkamp.

The instrument is 30 inches wide, 48 inches long, and stands 96 inches high. It is mobile in that it has three wheels and can be pulled while it is played. The builder is working on a plan whereby the "Modern Portative" can be self-propelled and played at the same time. A dozen screws disassembles the components so that it will fit into the builders' Chevette.

The organ is built of eight kinds of wood: birch, cherry, mahogany, maple, oak, pine, poplar, and walnut.

Of the instruments' seven keys, the first four have three stops (sliders): the remaining keys are solo. The pipes of the second, third, fourth, and fifth keys are interchangeable. A drawing of the chest layout shows the standard position of the pipes from which all the variations are done.

Owing to a lack of any "real" musical training, the builder became a composer and created his own *Orgelbook* consisting of seven compositions written for the instruments' dedication. A cryptographic diagram at the beginning of each work shows the position of the sliders, and indicates when and where the pipes should be re-arranged. In the compositions, numbers are used to represent keys, and numbers greater than the number of keys (8, 9 and 0) become pauses in the score. Part of the notation depends upon a square root system (composed with the help of a calculator) in which the final digit of the square root is sustained. The "beat" of the bellows (according to the builder/composer) accentuates the timing and gives the performer a rhythm section(!).

Jeffrey Chiplis claims that the future of the "Modern Portative" seems to be "in the traditional direction." He has already exposed his organ at a couple of street fairs and festivals, and is planning to write more "music" for this instrument.

The specification of the instrument can best be determined by studying the chest layout.

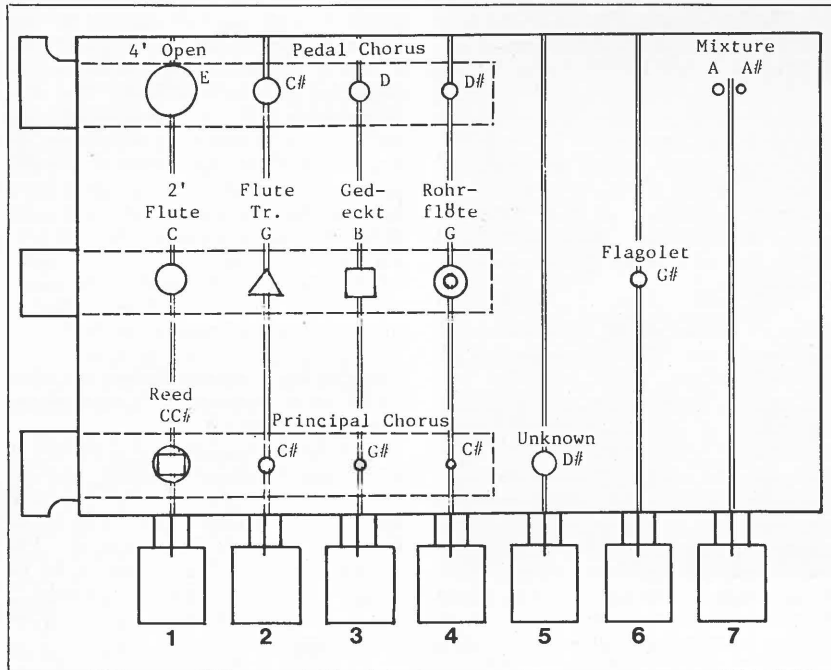

The composition shown above is from *Music for Modern Portative*, composed and deranged by Jeffrey Chiplis for the dedication of his unique instrument. The registration at the beginning shows that all of the instrument's stops are drawn, and that the pipes are re-arranged from their standard position on the windchest.

The drawing at left illustrates the normal location of the "Modern Portative's" resources. The dotted lines represent the location of the sliders, and the double lines show the centers of the wind channels for each of the seven keys.

## Rebuilt Organ

Michael Proscia of Bowdon, GA, has installed a 3-manual, 27-rank organ in the Carrollton Presbyterian Church, Carrollton, GA.

The hybrid instrument contains 17 ranks of Pilcher pipework, augmented by 10 new ranks, divided among the divisions.

The Choir division is located behind a central facade on non-functional pipes, retained from the church's previous instrument. The Great and Swell divisions are located (respectively) left and right of the facade.

The dedicatory recital was performed on March 13, 1983. Donovan Kicklighter is the organist of the church.

- |                    |                 |
|--------------------|-----------------|
| <b>GREAT</b>       | <b>CHOIR</b>    |
| 8' Principal       | 8' Melodia      |
| 8' Concert Flute   | 8' Dolce        |
| 8' Gamba           | 4' Spitz Flute  |
| 4' Octave          | 4' Flauto Dolce |
| 4' String Diapason | 2' Piccolo      |
| 2-3/4' Twelfth     | 8' Clarinet     |
| 2' Fifteenth       | Chimes          |
| Chimes             |                 |

- |                      |                      |
|----------------------|----------------------|
| <b>SWELL</b>         | <b>PEDAL</b>         |
| 16' Lieblich Gedeckt | 16' Open Diapason    |
| 8' String Diapason   | 16' Bourdon          |
| 8' Gedeckt           | 16' Lieblich Gedeckt |
| 8' Salicional        | 8' Octave            |
| 8' Viola Celeste     | 8' Bourdon           |
| 4' Praestant         | 8' Gedeckt           |
| 4' Harmonic Flute    | 4' Super Octave      |
| 2' Flauntina         | 16' Cornopean        |
| III Dolce Cornet     | 8' Cornopean         |
| 8' Cornopean         | Chimes               |
| 4' Oboe              |                      |
| Tremulant            |                      |

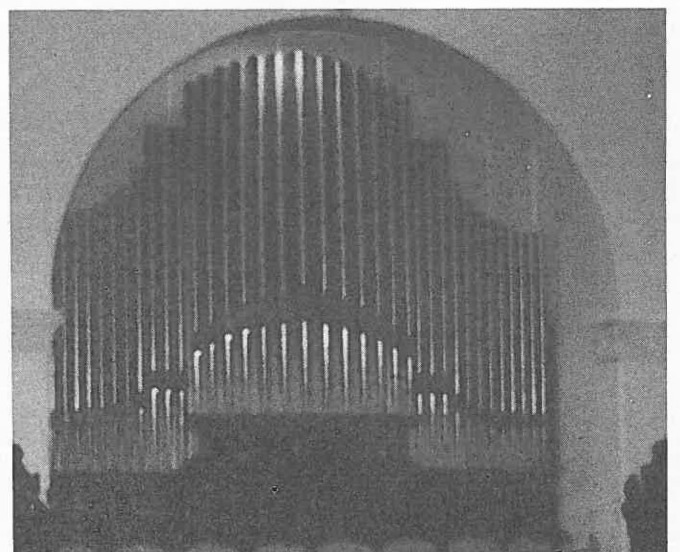



## Unique Italian Organs

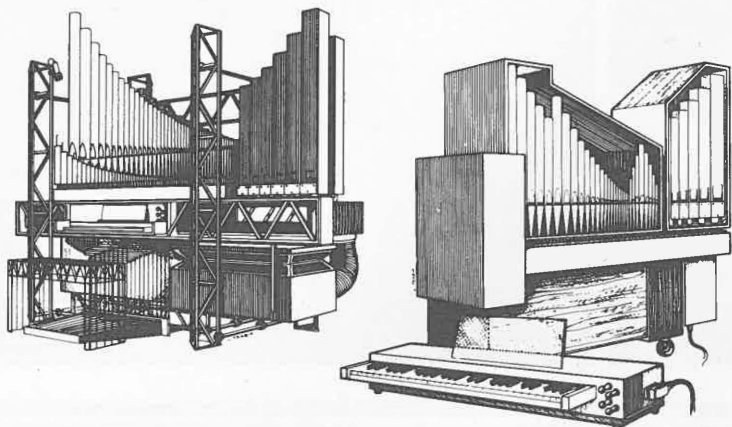
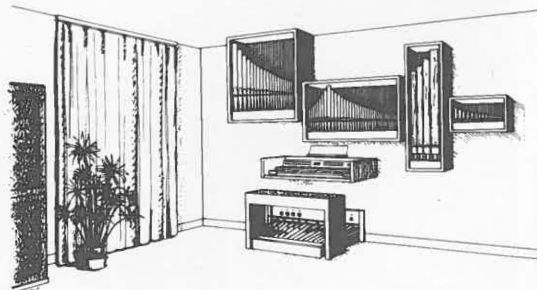

The Italian organbuilding firm of Gabriele Trabia is building some rather unique organs. As illustrated above, this firm is offering a "High-Tech" organ, an organ which literally hangs on the wall that consists of independent, made-to-order sections, and a single-manual organ whose keyboard may be placed on top of the console of another organ or on a piano.

The organ shown below makes us wish that THE DIAPASON had the facilities to publish in color. The pipes in the small black box above the keyboard appear to be of (any) normal polished metal. Those in the larger sunflower yellow box to the right of the console are a bright fire-engine red. The open metal pipes at the bass end of the keyboard are each of a different color: light blue, kaki, gold, rose, kelly green, peach, purple, grey, royal blue, brown, and (not seen in this view) red, and black and white checked!



FINE ORGAN LEATHERS SINCE 1800

BEVINGTONS AND SONS OF LONDON

NECKINGER MILLS  
 ABBEY STREET  
 BERMONDSEY  
 LONDON SE1 2AW

BROCHURES SENT  
 ON REQUEST

## Luther College Organ Rebuilt



After receiving a complete refurbishing in Minnesota, the Hendrickson organ of Luther College has been returned to the school, and to a new room built especially for it.

The organ, originally a 22-stop, 34-rank instrument built by Charles Hendrickson of St. Peter, MN in 1971, was built to a tonal design of Luther College organist, William Kuhlman in collaboration with Merrill Davis of Rochester, MN, and was installed in the school's Koren Hall. For Hendrickson, this project was his first attempt at constructing a mechanical-action instrument of its size.

Constant use by faculty and students for over eleven years aged the instrument by more than 200 years, compared to an average church organ.

In the fall of 1982, Luther College completed a new music hall, which included a studio built to house the Hendrickson. The instrument was dismantled and returned to St. Peter for restoration and enlarged to 25 stops and 37 ranks.

Because the touch of the tracker action was heavier than necessary in its original design, the system was revised. The overly large pallets in the bass registers and the pallet openings into the tone channels were reduced. The size of the trackers was decreased by more than 50 percent.

The original method of exhausting the tone channels with a lift-up valve operated by the pallet was eliminated. Normal felted bleed holes now exhaust the channels without adding any weight to the pallets. The total moving mass of

pallets, trackers and associated equipment is much less than before.

New keyboards and drawknobs were installed, but because the original setter-board combination action was in good condition, it was retained. The original slider seals, slider motors and slides were also kept.

The original flexible cable system used to control the movement of the glass swell shades was replaced with a more efficient torque-arm system.

Because the tonal design of the organ is one of its outstanding features, no changes in the instrument's sound were desired. However, several additions were made.

A new 4' Kegelpfeife was added to the Great division. The original design had no 4' flute on the great, but preparations for it had been made. An 8' Gedackt and a 2' Blockflöte were also added to the Pedal division.

The original design included a horizontal Trompette on an electric-action chest, available at 16', 8', and 4' pitches on the Great and 8', 4', and 2' on the pedal. Because the new studio is smaller than the hall which formerly housed the instrument, the rank was revoiced for use at only the 8' pitch on the Great.

In rebuilding the organ, the instrument's solid black walnut case was refinished and the flamed copper and tin principal facade pipes were cleaned and reburnished. New walnut pipe shades were installed to improve the appearance of the instrument and to diffuse the sound of the organ in the new room.

GREAT	SWELL	PEDAL
16' Quintade	8' Gedackt	16' Subbass
8' Prestant	8' Spitzgamba	8' Spitzprestant
8' Rohrflöte	8' Schwebung	8' Gedackt*
4' Octave	4' Spillflöte	4' Nachthorn
4' Kegelpfeife*	2' Prinzipal	2' Blockflöte*
2' Waldflöte	1-1/2' Quintflöte	IV Rauschpfeife
II Sesquialter	IV Scharff (%)	16' Fagott
IV-VI Mixture	16' Dulzian	
8' Trompette	8' Schalmey	
Tremulant	Tremulant	
	Zimbelstern	

\*New ranks

## Immanuel Lutheran Church Valparaiso, Indiana

Steiner-Reck Organbuilders of Louisville, KY has installed a new two manual mechanical action organ at Immanuel Lutheran Church, Valparaiso, IN.

The 25-stop, 34-rank organ is fully encased and located in the left, rear corner of the church's nave. The case is of white oak, stained in a light brown finish.

Both 8' ranks of the Pedal division are partially borrowed from the Great Division.

10 all-mechanical capture treadles are provided for combinations.

### GREAT

- 16' Quintadena
- 8' Principal
- 8' Rohrfloete
- 4' Octave
- 4' Flute
- 2' Blockfloete
- II Sesquialtera
- 2' Octave
- IV-V Mixture
- 8' Trompete
- Swell to Great

### SWELL

- 8' Bourdon
- 8' Gemshorn
- 4' Principal
- 4' Spitzfloete
- 2' Italian Principal
- 1½' Quint
- III-IV Scharff (½')
- 8' Krummhorn
- Tremulant

### PEDAL

- 16' Subbass
- 8' Principal
- 8' Gedacktpommer
- 4' Choralbass
- IV Mixture (2')
- 4/5' Terz
- 16' Fagotto
- 8' Trompete
- Great to Pedal 8'
- Swell to Pedal 8'

The Levsen Organ Company of Buffalo, IA has installed a new electric-action 16 rank organ in St. Patrick's Church, Clinton, IA. Some pipework from the church's former instrument was retained for this installation.

### GREAT

- 8' Open Diapason
- 8' Holzgedeckt
- 8' Viole d'Orchestra (S)
- 8' Viole Celeste (S)
- 8' Dulciana
- 4' Octave
- 4' Waldflöte
- 2' Fifteenth (ext.)
- 8' Clarinet
- 8' Trumpet (S)
- Chimes

### SWELL

- 8' Viole d'Orchestra
- 8' Viole Celeste
- 8' Quintadena
- 4' Violina (ext.)
- 4' Harmonic Flute
- 2½' Nazard (ext.)
- 2' Piccolo
- 1' Sifflöte (ext.)
- 8' Trumpet
- 8' Vox Humana
- 4' Oboe
- Tremolo

### PEDAL

- 16' Bourdon
- 16' Violin
- 10½' Quinte Bass (ext.)
- 8' Principal (G)
- 8' Gedeckt (ext.)
- 8' Violin Cello (ext.)
- 4' Octave (G)
- 4' Flute (ext.)
- 2' Bloch Flute (ext.)
- 8' Trumpet (S)

## Austin Rebuilds for Winnetka, IL Church

At right: New exposed pipework of Christ Church's redesigned Great division.

Below: One section of the divided Antiphonal division, designed to assist congregational singing.

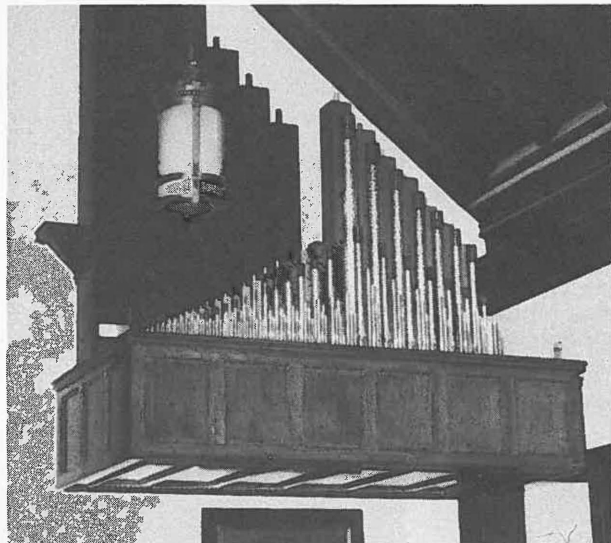

Austin Organs, Inc., has completed extensive tonal and mechanical rebuilding of and additions to their Opus 1274 in Christ Church (Episcopal), Winnetka, Illinois. Installed in 1924 the organ reflected the orchestral organ era and was played by Marcel Dupré. Modest tonal changes and additions were made by Austin in 1955.

The present 4-manual instrument has 75 ranks, of which 43 are new, 8 are incorporated from the 1955 changes and 24 are retained from the original installation. The tonal scheme was drawn up by Rick L. Erickson, organist-choirmaster of the church, in cooperation with the builders.

During the entire planning, building and finishing of the instrument it was kept constantly in mind that in this parish the primary function of the organ is to accompany the choral service, and to a lesser extent to lead congregational singing and provide organ voluntaries. Within the limitations of the acoustics and the instrument's location, the character of an English cathedral organ with Romantic leanings has been achieved.

The church's Choir of Men and Boys, which this spring celebrates its 85th anniversary, dictated the need for substantial chancel divisions of broad scaling, wide variety of colour, but modest power. Retaining and reacting the old manual chests in the chancel chambers for the Swell and Choir divisions meant a slightly unorthodox balance of stops; the new Great is exposed in front of the Swell, Choir and Pedal and above and behind the north choirstalls, providing a complete 3-manual instrument for the choir.

Christ Church is an historical building, basically being an early Edwardian copy of St. Martin's Church, Canterbury—the oldest parish church in England, much of which dates back to the 6th century. In 1955 this low-roofed and narrow building was considerably lengthened and a wide side aisle added, thus presenting considerable "projection" and "presence" problems for both the choir and the organ. The unenclosed Transept division positioned at the front of the nave at the Crossing, and the Antiphonal Organ on the back wall are

designed for congregational accompaniment. The latter division is lightly and clearly voiced, being exposed on both sides of a large window, and complements and blends with the somewhat "recast" Echo Organ located in a Tower chamber. The two high-pressure reeds contrast in timbre and power and are both located at the Crossing.

Because one good central-axis location for the organ was impossible, the nature of the tonal scheme is atypical of most contemporary American organ building, and balance between and control of the many manual divisions scattered around the room is confounding to a visiting organist. The use of six different wind pressures helps provide tonal contrast between similar divisions and stops. The organ works well and the sound delineated between "choir" and "nave" organs blends well together, supporting singers in both locations without becoming too loud or muddy in either.

The organ was installed by Hugh H. Sears, and tonally finished by Zoltan Zsitvay, both of Austin Organs.

### GREAT

- 16' Double Open Diapason
- 8' Open Diapason 1
- 8' Open Diapason 2
- 8' Harmonic Flute
- 4' Octave
- 2' Super Octave
- IV Mixture (19, 22, 26, 29)
- 8' Trumpet

### SWELL

- 8' Open Diapason
- 8' Chimney Flute
- 8' Salicional
- 8' Vox Angelica
- 8' Gemshorn (TC)
- 4' Principal
- 4' Spire Flute
- 2½' Nazard
- 2' Octavin
- 1½' Tierce (TC)
- IV Mixture (22, 26, 29, 33)
- 16' Double Trumpet
- 8' Cornopean
- 8' Oboe
- 4' Clarion
- 8' Vox Humana
- Tremulant

### CHOIR

- 16' Bourdon
- 8' Open Diapason
- 8' Melodia
- 8' Unda Maris (TC)
- 4' Principal
- 4' Koppel Flute
- 2' Fifteenth
- 1½' Octave Quint
- III Cymbel (29, 33, 36)
- 8' Clarinet
- Tremulant
- 8' Harmonic Festival Trumpet (SO)

### SOLO

- 8' Tuba
- 8' Harmonic Festival Trumpet
- 8' Diapason
- 8' Doppel Flute
- 8' Gamba
- 8' Gamba Celeste
- 8' French Horn
- Chimes

### ANTIPHONAL

- 8' Stopped Diapason
- 4' Principal
- 2' Fifteenth
- III Mixture (19, 22, 26)
- 16' Antiphonal Pedal Bourdon

### ECHO

- 8' Stenophone
- 8' Major Flute
- 8' Viole Anglica II
- 4' Fugara
- 8' Tromba
- Tremulant
- 16' Echo Pedal Bourdon

### TRANSEPT

- 8' Open Diapason
- 4' Octave
- III Grave Mixture (15, 19, 22)

### PEDAL

- 32' Acoustic Bass
- 16' Open Wood
- 16' Open Metal
- 16' Bourdon
- 16' Second Bourdon (CH)
- 8' Octave
- 8' Bass Flute
- 4' Fifteenth
- III Mixture (2', 1½', 1')
- 16' Trombone
- 16' Double Trumpet (SW)
- 8' Octave Trombone

## Electronic Installation

The Church of Our Saviour (Episcopal), Chicago has dedicated their recently acquired, used, electronic organ—an "American Classic" model manufactured by the Rodgers Organ

Company. The instrument had been used by the Chicago Symphony Orchestra during an extended remodeling period of Chicago's Orchestra Hall when the Orchestra's Lyon & Healey organ was removed, and until such time as a new organ, built by the M.P. Möller

Company was installed.

According to the bulletin published for the dedication service for this installation, the instrument's sound "emanates from over 75 various speaker cones driven by 900 watts of power."

The installation and tonal finishing of

this instrument was accomplished by employees of the Rodgers Organ studio of Elmhurst, IL.

Organists who participated in the dedication service were William Ferris, organist of the parish, Thomas Weisflog, and William D. Dickinson.



## New Organs

A choir organ has recently been installed in Holy Name Cathedral (R.C.), Chicago. Built by Casavant Frères, Ltée of St. Hyacinthe, Quebec, as their Opus 3537, this mechanical-action instrument was dedicated in September, 1982. The dedicatory recital was performed by Mireille Lagacé of Montreal.

Located on the epistle side of the sanctuary, facing the nave, the instrument is completely free-standing and encased with the Grand Orgue and Pedale divisions on one chest entablatured over the base which contains the Positif division in "Brustwerk" position. All divisions are unenclosed.

The organ consists of 19 stops and 25 ranks in a tonal design of French scaling

and stop nomenclature. It uses slightly unequal temperament with a wind pressure of 80 mm. Manual compasses are 56 notes and the pedal compass is 30 notes. The pedalboard is flat. Couplers are engaged by drawknobs or by foot levers, the latter of which are mechanical reversibles. The Zimbelstern is also engaged by foot lever.

The case is solid oak, with a double-depth collage treatment of pipeshades which evokes an abstract flame motif echoing similar building decorations in the cathedral from when it was remodeled in 1968-69. Facade pipes are 70% tin. The mirror treble pipes in the flats are all different speaking pipes winded separately from the back of the foot.

CLAVIER I (G.O.)	CLAVIER II (POS)	PEDALE
8' Montre	8' Bourdon	16' Subbasse
8' Flute à Cheminée	4' Flute Conique	8' Octavebasse
4' Prestant	2' Doublette	4' Octave
4' Flute à Fiseau	1-1/3' Quinte	16' Basson
2-2/3' Nasard	III Cymbale (2/3')	I-P
2' Quarte de Nasard	8' Musette	II-P
1-3/5' Tierce	Tremblant	
V Fourniture (1-1/3')		Zimbelstern (5 bells)
8' Trompette		
II-I		

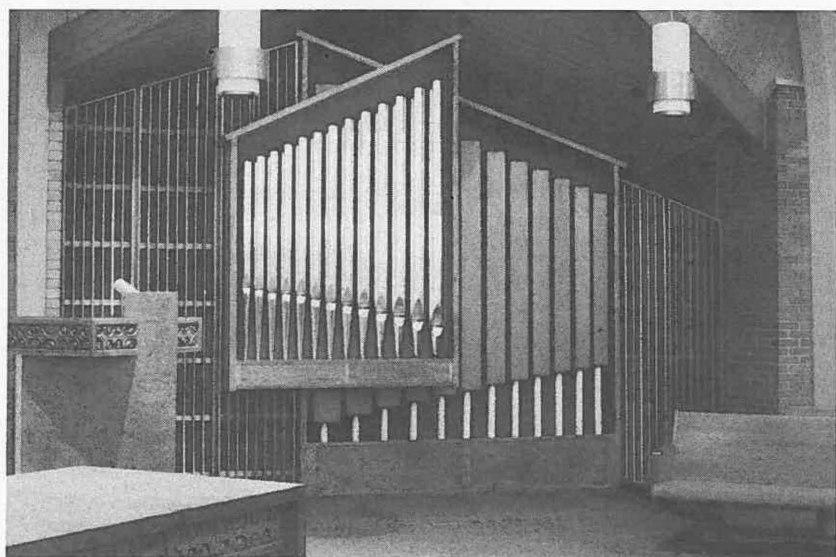

The First Christian Church of Richardson, TX is a striking octagonal building with a ceiling that rises to a peak near the center of the room. Each of the eight walls rises to a height of about eleven feet with no high location where an organ could be placed. The builder, Ross King Company of Ft. Worth, TX, decided to place the organ in a recess along one wall which had formerly been used for choir seating, relocating the choir to a new position in the front of the organ. The facade of the instrument

was designed to project the sound over its top so that the organ would not be too loud for those sitting adjacent to it, and so that it could be adequately heard at any point in the room.

Increased flexibility in this installation was achieved by careful voicing of many ranks to contribute to the ensemble in their sub and super-octave ranges. A major objective was to provide an organ that contained considerable variety with an abundance of quiet colors, suitable for this congregation.

Goulding & Wood, Inc. of Bloomington, IN has installed a 2-manual, 31-rank organ in Trinity Episcopal Church, Bloomington.

The tonal design of the instrument was designed to increase the organ's flexibility so that the Swell can be used at sub-octave pitch as an "English" Swell, and the Great can be used at the super-octave pitch as a Brustwerk.

The larger facade pipes (center and end towers) are of flamed copper. The

organ chests are of the slider and pallet type with an electro-pneumatic control action.

The relatively small size of the room allowed for mixtures of less than normal number of ranks.

Organists of the parish are Dr. Robert Rayfield and Thomas Wood, both of whom are affiliated with Indiana University. Mr. Wood is also a principal officer of the firm that built this instrument.

GREAT	SWELL	PEDALE
16' Gedeckt	8' Bourdon	32' Contra Bourdon (1-12 res.)
8' Principal	8' Salicional	16' Spitz Principal
8' Rohr Flute	8' Salicional Celeste (TC)	16' Subbass
4' Octave	4' Principal	16' Gedeckt (GT)
4' Spitz Flute	4' Spiel Flute	8' Spitz Principal (ext.)
2' Block Flute	2' Octave	8' Pommer
III Sesquialtera (TF)	1 1/2' Quint	4' Choral Bass
II Mixture	II Scharff	2' Octave
8' Schalmey	16' Fagot	II Mixture
Chimes	8' Trompette	16' Posaune
Tremolo		8' Trumpet



GREAT	SWELL	PEDALE
8' Principal	16' Gedeckt	16' Subbass
8' Gedeckt	8' Rohrflute	16' Gedeckt
4' Octave	8' Viole	8' Principal
4' Rohrflute	8' Celeste	8' Rohrflute
2' Super Octave	4' Principal	5 1/2' Quint
IV Mixture	4' Flute	4' Octave
8' Cromorne	2 1/2' Nazard	4' Gedeckt
Great to Great 4'	2' Spitzflute	16' Trumpet
Swell to Great 8'	1 1/2' Tierce	8' Trumpet
Swell to Great 4'	II Cymbal	4' Cromorne
	8' Trumpet	Great to Pedal 8'
	Tremulant	Swell to Pedal 8'
	Swell Unison Off	
	Swell to Swell 4'	



# 1983 Convention



## American Institute of Organbuilders

DATE: October 2-5, 1983

PLACE: Airport Hilton Plaza Hotel, Kansas City, MO

HEADQUARTERS: P.O. Box 213, Lawrence, KS 66044

## MILNAR ORGAN CO.

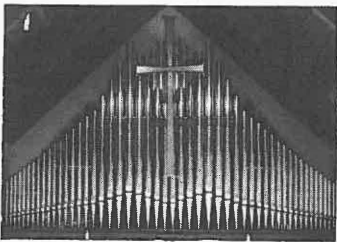

- NEW ORGANS
- REBUILDING
- MAINTENANCE

EAGLEVILLE, TN 37060

(615) 264-6400



H  
U  
P  
A  
L  
O

HUPALO ORGAN PIPE CO., INC.

18 VERNON AVE., VERNON, CT 06066

(203) 871-7067

"PIPES for the sound you want"

PLEASE SEND FOR OUR FREE CATALOG  
INQUIRIES FOR YOUR SPECIAL NEEDS WELCOME

## Lehigh ORGAN COMPANY

24 PINE STREET  
MACUNGIE, PA. 18062  
(215) 966-3561

## NOACK

THE NOACK ORGAN CO., INC.  
MAIN AND SCHOOL STREETS  
GEORGETOWN, MASS. 01833

## S. G. Price

PIPE ORGANS

NEW • REBUILDING SPECIALISTS

P.O. BOX 60841  
HOUSTON, TEXAS 77205 (713) 446-2312

## Pipe Organ Sales and Service, Inc.

P.O. Box 838 • Lithonia, Ga. 30058 • 404/482-4845  
Serving Pipe Organs of All Types in the Southeast

Consulting	Rebuilding
Additions	Annual Maintenance
Repairs	Contracts
	New Organs



### — THE FULLY ACCEPTABLE ALTERNATIVE —

AOB ALONE provides an independently voiced and tuned generator in place of each pipe for natural warmth and chorus.  
AOB ALONE provides note-by-note control of articulation, harmonic development, scaling, and tonal finishing of each voice.  
AOB offers organs of uncompromising quality built to our standard or your fully custom specifications.

## Associated Organ Builders

headquarters and manufacturing  
3419 "C" ST N.E.  
AUBURN, WA 98002  
206/852-4866

sales and marketing  
2921 S. 104TH ST.  
OMAHA, NE 68124  
402/393-4747

## Rebuilt Organ

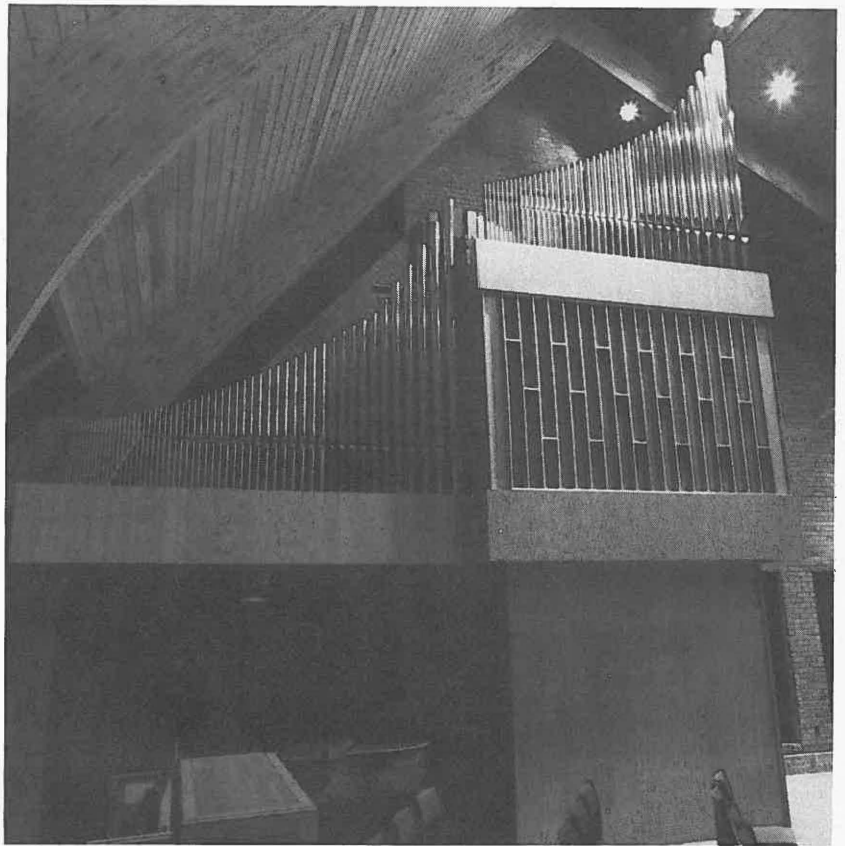

McEvers Company, organbuilders, of Makanda, IL has enlarged, revised and encased an instrument that began its existence as a Möller organ in 1926 for the First Presbyterian Church of Bloomington, IL.

The instrument was rebuilt by Möller in 1955, and in 1972 it was rebuilt and reinstalled by Robert Dial in a temporary location at Union Presbyterian Church, Bloomington, in a new parish hall serving the merged congregation of First Presbyterian and the Congrega-

tional Church.

The organ has subsequently been enlarged to 18 ranks, and encased by the McEvers Company for St. Luke Union Church, a federated church with United Presbyterian and United Church of Christ congregations in their new sanctuary.

The dedicatory recital was performed by David M. Gehrenbeck of Illinois Wesleyan University.

James M. McEvers is a member of the American Institute of Organbuilders.

### GREAT

- 8' Principal
- 8' Gedackt
- 8' Dulciana
- 4' Octave
- 4' Gedackt
- 4' Spitzflöte
- 2' Spitzflöte
- 1½' Quinte
- III-IV Mixture (prep.)
- Chimes

### SWELL

- 8' Stopped Diapason
- 8' Salicional
- 8' Voix Celeste
- 4' Spitzprinzipal
- 4' Quintaten
- 2' Weitoktav
- III Plein Jeu
- 8' Trompette
- Tremolo

### PEDAL

- 16' Bourdon
- 8' Principal
- 8' Bass Flute
- 4' Choralbass

## Residence Installation

The firm of Henri Saby, organ builders of St. Uze in the Drôme region of France has built a mechanical-action practice organ for the residence of Lynne Davis, recitalist. The instrument's resources consist of a single 8' Bourdon which is available on two manuals and on the pedal in the following manner:

Manual I: 8', II to I

Manual II: 4'

Pedal: 8', 4'

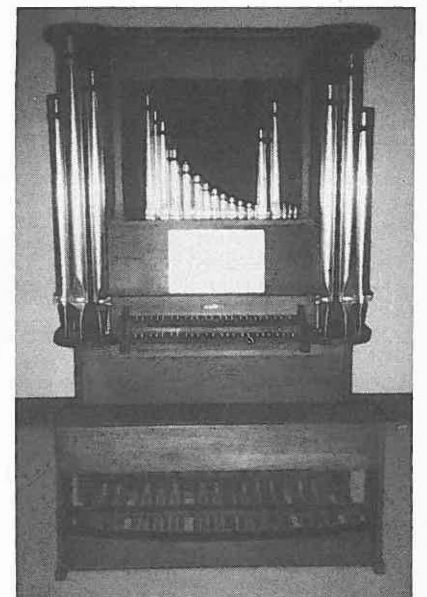

## Reisner

REISNER, INC.

240 North Prospect Street, P. O. Box 71  
Hagerstown, Maryland 21740



**Alexander Anderson**

Knowles Memorial Chapel  
Rollins College  
Winter Park, Florida 32789

**robert anderson**

SMD FAGO  
Southern Methodist University  
Dallas, Texas 75275



**DAVID ROTHE,** Organist  
California State University, Chico  
St. John's Episcopal Church, Chico  
Recitals Workshops  
P.O. Box 203 (916) 345-2985  
Forest Ranch 895-6128  
California 95942



CHARLOTTE AND WILLIAM  
**ATKINSON**

FIRST PRESBYTERIAN CHURCH  
2001 El Camino Real  
Oceanside, California 92054

**WILLIAM AYLESWORTH**

D. M.  
Evanston, Illinois

Gruenstein Award Sponsor

**CHICAGO CLUB OF WOMEN ORGANISTS**

Dorothy N. Petty, SPC, President

Founded 1928

Workshops Recitals

**ROBERTA BITGOOD**  
S.M.D., F.A.G.O., Ch. M.  
13 Best View Road  
Quaker Hill, Connecticut 06375

**CHARLES BOEHM**

TRINITY LUTHERAN CHURCH  
Hicksville, N.Y.  
NASSAU COMMUNITY COLLEGE  
Garden City, N.Y.

William F. &amp; Mary H.

**BRAME**

St. Mary's Episcopal Church

Box 1231  
Kinston, NC 28501

**CHARLES S. BROWN**

DMA FAGO CHM  
North Texas State University  
Denton 76203  
St. John's Episcopal Church  
Dallas  
The Denton Bach Society

**LARRY PALMER**

Professor of  
Harpsichord and Organ  
Director of  
Graduate Studies in Music  
Meadows School of the Arts  
SOUTHERN METHODIST UNIVERSITY  
Dallas, Texas  
Musical Heritage Society recordings

**CAROL TETI**

Zion Lutheran Church  
Indiana University of Pennsylvania  
Indiana, Pa. 15701

**ROBERT CLARK**

School of Music

ARIZONA STATE UNIVERSITY  
TEMPE, ARIZONA 85281

**Harry E. Cooper**

Mus. D., F.A.G.O.  
RALEIGH, N. CAROLINA

**MICHAEL CORZINE**

School of Music  
Florida State University  
Tallahassee

**WALLACE M. COURSEN JR.**

F.A.G.O.  
Bloomfield, New Jersey

**JOHN EDWARD COURTER**

F.A.G.O.

Recitalist

Berea College Berea, Ky. 40404

**DAVIDSON**

Jerry Susan  
PhD, MSM, AAGO, ChM MSM, ChM  
Louisiana State University  
St. John's St. Alphonsus  
United Methodist Roman Catholic  
Baton Rouge, Louisiana

First Prize  
St. Albans  
1975

International  
Recitalist

**LYNNE DAVIS**

2 rue de l'Eglise  
27710 St. Georges-Motel • France

**DAVID GOODING**

Resident Music Director/Consultant

THE CLEVELAND PLAY HOUSE

Cleveland, OH 44106

**EUGENIA EARLE**

Teachers College, Columbia University  
Harpsichord Recitals  
Performance Practice Workshops  
15 West 84th Street, New York, N.Y. 10024

**STEVEN EGLER**

Central Michigan University  
First Presbyterian Church  
Mt. Pleasant, Michigan 48858  
SOLO Shelly-Egler  
RECITALS Flute and Organ Duo

LAWRENCE

**ROBINSON**

VIRGINIA COMMONWEALTH UNIVERSITY

RICHMOND, VIRGINIA

*Sherry Smith Withers*

INTERNATIONAL CONCERT ARTIST

Instructor of Organ  
Sam Houston State University  
Huntsville, Texas U.S.A. 77341  
713/294-1378

**KATHRYN ESKEY**

The University of  
North Carolina  
at Greensboro

**GEORGE ESTEVEZ**

ch.m.  
Chicago Chamber Choir

**JOHN FENSTERMAKER**

GRACE CATHEDRAL  
SAN FRANCISCO

**Robert Finster**

TEXAS BACH CHOIR  
ST. LUKE'S EPISCOPAL CHURCH  
SAN ANTONIO

R  
E  
C  
I  
T  
A  
L  
S**JOHN HOLTZ**

Faculty: HARTT SCHOOL, University of Hartford  
Organist: CENTER CONGREGATIONAL CHURCH, Hartford

**JAMES FREY**

Dixboro United Methodist Church  
Ann Arbor, Michigan

ELLEN KURTZ

**FUNK**

M.Mus. A.A.G.O.  
Concord, California

**HENRY FUSNER**

S.M.D., A.A.G.O.  
First Presbyterian Church  
Nashville, Tennessee 37220

**John W. Gearhart III**

B.A., M.Mus.  
St. Paul's Episcopal Church  
P.O. Box 8427  
Mobile, Alabama 36608

**THE DIAPASON**

380 NORTHWEST HIGHWAY • DES PLAINES, IL 60016

Name .....

Street .....

City .....

State ..... Zip .....

Please allow six to eight weeks for delivery of first issue on new subscriptions

NEW SUBSCRIBER  
Please begin new subscription

RENEWAL  
(Attach to mailing label)

ENCLOSED IS

 \$26.00 - 3 years \$18.00 - 2 years \$10.00 - 1 year

## Robert Glasgow

School of Music  
University of Michigan  
Ann Arbor

## BRUCE GUSTAFSON

Franklin and Marshall College  
Lancaster, Pennsylvania

## JAMES J. HAMMANN

M.M. - A.A.G.O.  
Central Methodist Church  
Detroit, Michigan

WILL O. HEADLEE  
SCHOOL OF MUSIC  
SYRACUSE UNIVERSITY  
SYRACUSE, NEW YORK 13210

## VICTOR HILL

Harpichord and Organ  
Williams College  
St. John's Episcopal Church  
Williamstown, Mass. 01267

## d. deane

**hutchison**  
portland, oregon

## Laurence Jenkins

- Recitalist
- The Sine Nomine Singers
- London Correspondent: THE DIAPASON

## MICHELE JOHNS

A.Mus.D  
Organ — Harpsichord  
The University of Michigan  
School of Music

## KIM R. KASLING

D.M.A.  
St. John's University  
Collegeville, MN 56321

ORGAN RECITALS  
FRANCIS JOHN KOSOWICZ  
"SILFRAN"

13C HARMONY ROUTE  
SPENCER, WEST VIRGINIA 25276  
304-927-4679

## RICHARD W. LITTERST

M. S. M.  
SECOND CONGREGATIONAL CHURCH  
ROCKFORD, ILLINOIS

## BETTY LOUISE LUMBY

DSM • FAGO  
UNIVERSITY OF MONTEVALLO  
MONTEVALLO, ALA. 35115

## Antone Godding

School of Music  
Bishop W. Angie Smith Chapel  
Oklahoma City University

## E. LYLE HAGERT

Minneapolis

## DAVID S. HARRIS

Organ Consultant  
1332 Del Mar Parkway  
Aurora, CO 80010

## KENT HILL

MSC Music Department  
Mansfield, PA 16933

## Harry H. Huber

D. Mus.  
Kansas Wesleyan University, Emeritus  
University Methodist Church  
SALINA, KANSAS

## FRANK IACINO

St. Andrew's Church  
24 Stavebank Rd.  
Mississauga, Canada  
Recitals Records

## CHARLES D. JENKS

First Congregational Church  
Des Plaines, IL 60016

## BRIAN JONES

Boston 02181  
Wellesley Congregational Church  
Noble & Greenough Dedham Choral  
School Society

## JAMES KIBBIE

D.M.A.  
The University of Michigan  
School of Music  
Ann Arbor, MI 48109

## WILLIAM KUHLMAN

Decorah, Iowa 52101  
Luther College

## David Lowry

School of Music  
Winthrop College  
Rock Hill, South Carolina 29733

## William MacGowan

Bethesda-by-the-Sea  
Palm Beach, Florida

## Calendar

This calendar runs from the 15th of the month of issue through the following month. The deadline is the first of the preceding month (Jan. 1 for Feb. issue). All events are assumed to be organ recitals unless otherwise indicated and are grouped within each date north-south and east-west. \* = AGO chapter event, \*\* = RCCO centre event, + = new organ dedication, ++ = OHS event.

Information cannot be accepted unless it specifies artist name, date, location, and hour in writing. Multiple listings should be in chronological order; please do not send duplicate listings. THE DIAPASON regrets that it cannot assume responsibility for the accuracy of calendar entries.

### UNITED STATES East of the Mississippi

15 SEPTEMBER  
Richard Shaw; Duquesne Univ, Pittsburgh, PA 12:30 pm

18 SEPTEMBER  
Palestrina, Missa Ad fugam; Church of the Advent, Boston, MA 11 am  
Pierce Getz; National Cathedral, Washington, DC, 5 pm  
David Craighead, Jehova Evangelical Lutheran Church, St. Paul, MN

20 SEPTEMBER  
Todd Wilson, with trumpet; Cathedral of the Incarnation, Garden City, NY 8 pm

21 SEPTEMBER  
Karel Paukert; Cleveland, Museum, Cleveland, OH 12 noon

25 SEPTEMBER  
Langlais, Missa In simplicitate; Church of the Advent, Boston, MA 11 am  
Richard Neubert; St Matthew's Lutheran, White Plains, NY 4 pm  
Mark Buxton, St Thomas Church, New York, NY 5:15 pm  
Anne Wilson; Marcellus United Methodist, Marcellus, NY 7:30 pm  
Pierce Getz; Levanon Valley College, Anville, PA, 8 pm  
\*Gerre Hancock, Church of the Covenant, Cleveland, OH 5:00 pm  
\*John Obetz; Calvary Episcopal, Pittsburgh, PA 8 pm  
Susan Stieve; First Presbyterian, Kalamazoo, MI 12 noon  
Charles Tompkins; Hennepin Ave United Methodist, Minneapolis, MN 4 pm  
Robert L. Simpson; Cathedral of St Philip, Atlanta, GA 5 pm

27 OCTOBER  
Jerome Butera; First Methodist, Chicago, IL 12:10 pm

28 SEPTEMBER  
John Obetz; Calvary Episcopal, Shadyside, PA 8 pm  
Karel Paukert; Cleveland Museum, Cleveland, OH 12 noon  
Peter Planyavsky; Cleveland Museum, Cleveland, OH 8:30 pm  
Robin Styberski; First Presbyterian, Kalamazoo, MI 12 noon

29 SEPTEMBER  
Palestrina, Missa Brevis; Church of the Advent, Boston, MA 6:30 pm  
James Hess; Duquesne Univ. Pittsburgh, PA 12:30 pm

30 SEPTEMBER  
Gerre Hancock; Illinois Wesleyan Univ, Bloomington, IL 8 pm

1 OCTOBER  
Ann Labounsky, workshop; Grace Lutheran, State College, PA 10 am

2 OCTOBER  
John Weaver; Madison Ave Presbyterian, New York, NY 4 pm  
Ann Labounsky; Grace Lutheran, State College, PA 8 pm  
Jeffrey Brillhart; Bryn Mawr Presbyterian, Bryn Mawr, PA 7:30 pm  
Norman Selby; Cathedral of St Philip, Atlanta, GA 5 pm  
Marilyn Keiser; Westminster Presbyterian, Dayton, OH 4 pm  
Carol Teti; Tainter Memorial Theater, Menomonie, WI 7:30 pm  
Anne Wilson; United Church of Oak Park, Oak Park, IL 3 pm

3 OCTOBER  
Daniel Roth; First Presbyterian, Lancaster, PA 8 pm

5 OCTOBER  
Mark Buxton; St John's Church, Washington, DC 12:10 pm  
Craig J. Cramer; First Presbyterian, Kalamazoo, MI 12 noon

6 OCTOBER  
Nancy Watson; Duquesne Univ, Pittsburgh, PA 12:30 pm

9 OCTOBER  
Robert Gonnella; Madison Ave Presbyterian, New York, NY 4 pm  
Mark Sweeney; Cathedral of St Philip, Atlanta, GA 5 pm  
Bach Festival; First Presbyterian, Nashville, TN 7:30 pm  
C. William Ziegenfuss; Christ Church Cathedral, New Orleans, LA 4 pm

11 OCTOBER  
David Billings, with instruments; Pittsburgh Theological Seminary, Pittsburgh, PA 8 pm

12 OCTOBER  
Albert Russell; ST John's Church, Washington, DC 12:15 pm  
WMU Chorale; First Presbyterian, Kalamazoo, MI 12 noon

13 OCTOBER  
Marilyn Mason; Wingate College, Wingate, NC  
John Henninger; Duquesne Univ, Pittsburgh, PA 12:30 pm

14 OCTOBER  
Earl Miller; First Congregational, Great Barrington, MA 8 pm

16 OCTOBER  
Gospel Song Fest; First Congregational, Great Barrington, MA  
\*Brett Wolgast; Main Street United Methodist, Suffolk, VA 4 pm  
Robert Baker; First United Methodist, Brevard, NC

Frederick Hohman; Lutheran Church of the Good Shepherd, Lancaster, PA  
\*Larry Smith; Westminster Presbyterian, Stuebenville, OH 4 pm  
Bach-a-thon; St James Cathedral, Chicago, 12:30-8:30 pm  
Jerome Butera; St Peter United Church, Skokie, IL 4 pm  
Byron L. Blackmore; Our Savior's Lutheran, La Crosse, WI 4 pm

18 OCTOBER  
\*Brett Wolgast; River Road Baptist, Richmond, VA 8 pm

19 OCTOBER  
Carole Feather Martin; St John's Church, Washington, DC 12:10 pm

20 OCTOBER  
Jean Furmanek; Duquesne Univ, Pittsburgh, PA 12:30 pm

21 OCTOBER  
Festal Evensong; Cathedral of the Incarnation, Garden City, NY 8 pm  
Joan Lippincott; Messiah Lutheran, S. Williamsport, PA  
Marchal Symposium; Duquesne Univ, Pittsburgh, PA (also 22)  
Ann Labounsky, William Hays; St Paul of the Cross Monastery, Pittsburgh, PA 8 pm  
Raymond Daveluy; St Joseph's Church, Springfield, OH 8 pm

## THOMAS MURRAY

Yale University  
Institute of Sacred Music

School of Music



**22 OCTOBER**

Zsigmond Szathmary, workshop; West Side Presbyterian, Ridgewood, NJ 9-1

**23 OCTOBER**

Robert Edward Smith, harpsichord; First Congregational, Waterbury, CT 4 pm

Zsigmond Szathmary; West Side Presbyterian, Ridgewood, NJ 4 pm

Raymond Daveluy; St Stephen's Episcopal, Millburn, NJ 3 pm

Ann Longdon Hood; Cathedral of St Philip, Atlanta, GA 5 pm

Arthur Vidrich, with trumpet; Zion Lutheran, Indiana, PA 7 pm

Huw Lewis; First English Lutheran, Grosse Pointe Woods, MI 3 pm

Jerome Butera; Park Ridge Community Church, Park Ridge, IL 3:30 pm

**26 OCTOBER**

Michael Parrish; St John's Church, Washington, DC 12:10 pm

**27 OCTOBER**

Mark King; Duquesne Univ, Pittsburgh, PA 12:30 pm

**30 OCTOBER**

John Rose; United Church of Johnson, Johnson, VT 3 pm

David Hurd; St Mark & All SS, Abescun Highlands, NJ 3 pm

William Bates; First Presbyterian, Gastonia, NC 3 pm

Chesley Bowden III; Cathedral of St Philip, Atlanta, GA 5 pm

Frederick Swann; West End United Methodist Church, Nashville, TN

Anne Wilson; Church of the Savior, Canton, OH 4 pm

+Marianne Webb; First Evangelical Lutheran, Murphysboro, IL 4 pm

**UNITED STATES****West of the Mississippi****18 SEPTEMBER**

David Herman; Drake University, Des Moines, IA 3 pm

Larry Palmer (HC) Meadows Museum, SMU, Dallas, TX 4 pm

John Pagett; Zion Lutheran, San Francisco, CA 4 pm

Karen Taylor; Luther Memorial, Burbank, CA 4 pm

**25 SEPTEMBER**

Jean Guillou; Plymouth Congregational, Minneapolis, MN 3 pm

Larry Smith; St Mary's Church, Dubuque, IA 3 pm

David Spicer; Frist Presbyterian, Lincoln, NE 4 pm

**27 SEPTEMBER**

James Moeser; Arkansas College, Batesville, AR 8:00 pm

**29 SEPTEMBER**

Larry Palmer (HC); Master Class, Univ of TX, San Antonio 3 pm

**30 SEPTEMBER**

\*Roberta Gary; St John's Episcopal Cathedral, Denver, CO 8 pm

\*Jean Guillou; Church of the Magdalene, Wichita, KS 8 pm

Larry Palmer (HC); Univ of TX, San Antonio 7:30 pm

**1 OCTOBER**

\*Roberta Gary, masterclass; St John's Episcopal Cathedral, Denver, CO 10 am

**2 OCTOBER**

Carlene Neihart; Grand Avenue Temple, Kansas City, MO 2:30 pm

John Pagett; Davis Community Church, Davis, CA 3 pm

**4 OCTOBER**

Frederick Swann; Trinity Episcopal, Tulsa, OK 8 pm

**7 OCTOBER**

Frederick Swann; Frist Presbyterian, Omaha, NE

**9 OCTOBER**

James Moeser; Second Presbyterian, Little Rock, AR 3 pm

Organ Transcriptions Festival; St Cross Episcopal, Hermosa Beach, CA

**10 OCTOBER**

James Moeser, workshop; Second Presbyterian, Little Rock, AR

**14 OCTOBER**

+Ted Alan Worth; St Brigid's, San Francisco, CA 8 pm

Robert Glasgow; First Methodist, Palo Alto, Ca 8 pm

**16 OCTOBER**

Marianne Webb; Buena Vista College, Storm Lake, IA 4 pm

**17 OCTOBER**

David Craighead, masterclass; Dordt College, Sioux Center, IA

**18 OCTOBER**

David Craighead; Dordt College, Sioux Center, IA 8 pm

**21 OCTOBER**

Paul Lee, Steven Lawson, duo organ; First Congregational, Los Angeles, CA 8 pm

**22 OCTOBER**

Peter Hurford; Green Lake Church, Seattle, WA 4 pm

Honegger, King David; Santa Ana HS Aud. Santa Ana, CA 8:30 pm

**23 OCTOBER**

Britten Festival; First Presbyterian, Lincoln, NE 4 pm

**30 OCTOBER**

Ladd Thomas; La Jolla Presbyterian, La Jolla, CA 4 pm

**INTERNATIONAL****17 SEPTEMBER**

Gillian Weir; St Paul's Cathedral, Wellington, New Zealand, 8 pm

**18 SEPTEMBER**

\*\*Jean Guillou; All SS Cathedral, Edmonton, Alberta, Canada 3 pm

**22 SEPTEMBER**

Gillian Weir; The Opera House, Sydney, Australia, 7:30 pm

**23 SEPTEMBER**

Jean Guillou; Christ Church, Calgary, Alberta, Canada 8 pm

**24 SEPTEMBER**

Gillian Weir, harpsichord; The Town Hall, Brisbane, Australia 7:30 pm

**30 SEPTEMBER**

Gillian Weir; The Festival Centre, Adelaide, Australia 8 pm (also 1 Oct.)

**5 OCTOBER**

Gillian Weir; Sydney Opera House, Sydney, Australia, 8 pm (also 6, 8, 10, 11 Oct.)

**12 OCTOBER**

Gillian Weir; The Town Hall, Sydney, Australia 8 pm

**16 OCTOBER**

\*\*John Searchfield, with ensemble; Robertson-Wesley United Church, Edmonton, Alberta, Canada 3 pm

**19 OCTOBER**

Gillian Weir; Monash University, Melbourne, Australia 8 pm

**22 OCTOBER**

Gillian Weir; The Concert Hall, Melbourne, Australia 8 pm (also 24, 25 Oct.)

**FREDERICK L. MARRIOTT**

ORGANIST — CARILLONNEUR

KIRK-IN-THE-HILLS

BLOOMFIELD HILLS, MICH. 48013

**WILLIAM H. MURRAY**

Mus. M F.A.G.O.

Church of the Mediator

Chicago, Ill.

**LEON NELSON**

THE MOODY CHURCH  
CHICAGO, IL 60614

FIRST PRESBYTERIAN CHURCH  
DEERFIELD, IL 60015

**JOHN DAVID PETERSON**

Music Department  
Memphis State University  
Memphis, Tennessee 38152

**DOUGLAS REED**

UNIVERSITY OF EVANSVILLE

EVANSVILLE, INDIANA

**Robert Shepfer**

Organist - Choirmaster  
SECOND PRESBYTERIAN CHURCH

Indianapolis, Indiana 46260

Recitals

**L. ROBERT SLUSSER**

MUS. M., A.A.G.O.

LA JOLLA PRESBYTERIAN CHURCH

LA JOLLA, CALIFORNIA

**DAVID SPICER**

First Presbyterian Church  
Director of Music

Nebraska Wesleyan University  
University Orchestra Conductor

Lincoln, Nebraska

**ADOLPH STEUTERMAN**

Memphis, Tennessee

Mus. Dec., F.A.G.O.

Southwestern at Memphis, Retired

Calvary Episcopal Church, Emeritus

**JONATHAN A. TUUK**

Immanuel Lutheran Church  
338 North Division Avenue  
Grand Rapids, Michigan 49503

Recitals

**DONALD W. WILLIAMS**

D.M.A.

Zion Lutheran Church

Concordia College

Ann Arbor, MI

**Max Yount**

beloit college, wis.

organ  
composition

harpsichord  
choir

**ERNEST MAY**

Dept. of Music,  
University of Massachusetts  
Amherst, Mass. 01003  
Trumpet/Organ Recitals  
Slide Lectures on Bach's Organ Music

**DAVID McCAIN**

ORLANDO

**RICHARD M. PEEK**

Sac. Mus. Dec.

Covenant Presbyterian Church  
1000 E. Morehead Charlotte, N. C.

**Robert M. Quade**

MSM, Hon RSCM

Organist — Choirmaster  
Saint Paul's Episcopal Church  
1361 West Market Street  
Akron, Ohio 44313

**John Russell  
Recitals**

The College of Wooster  
Music Director: The Wooster Chorus  
First Presbyterian Church, Wooster, OH

**ROBERT L.  
SIMPSON**

Cathedral of St. Philip  
2744 Peachtree Road N.W.  
Atlanta, Georgia 30305

**Robert W. Smith**

Historic First Christian Church

Charlottesville, Virginia

**Carl Staplin**

Ph.D., A.A.G.O.

Drake University  
First Christian Church  
DES MOINES, IOWA

**Thomas R. Thomas**

Palm Beach  
The Royal Poinciana Chapel  
Director of Music  
The Henry Morrison Flagler  
Museum  
Organist-in-Residence

**CLARENCE WATTERS  
RECITALS**

Trinity College  
Hartford, Connecticut

**RONALD WYATT**

Trinity Church

Galveston

**MARILYN MASON**

CHAIRMAN, DEPARTMENT OF ORGAN  
UNIVERSITY OF MICHIGAN  
ANN ARBOR

"... Ginastera's ... was by all odds the most exciting ... and Marilyn Mason played it with awesome technique and a thrilling command of its daring writing."

The American Organist, 1980

# CLASSIFIED ADVERTISING

Classified Advertising Rates  
will be found on page 30.

**ALL REPLIES  
TO BOX NUMBERS**  
that appear  
without an address  
should be sent to:  
**THE DIAPASON**  
380 Northwest Hwy.  
Des Plaines, IL 60016

## POSITIONS AVAILABLE

**ORGANIST-MUSIC DIRECTOR, FULL-TIME.** Duties include handbell choirs and brass ensemble. Restored 3-manual Erben tracker organ. Trinity United Methodist Church, McLean, VA. (703) 356-3312.

**ORGANBUILDERS WITH MINIMUM OF 4 YEARS** experience with mechanical organs. Gabriel Kney, 137 Falcon St., London, Ontario, Canada, N5W 4Z2.

**ORGANIST-CHOIR DIRECTOR FOR ESTABLISHED** downtown parish with many new families. Vibrant and energetic, to develop potential. One morning service (11 a.m.), plus availability for the family service (9:15 a.m.). Permanent part-time position with competitive salary. Studio and teaching facilities could be made available. Excellent acoustics with three manual Casavant. To commence Fall 1983, or when filled. Please apply: Dr. David Morrison, St. Paul's Anglican Church, P.O. Box 2919, Charlottetown, P.E.I., Canada, C1A 8C5.

**SALES & SERVICE REPRESENTATIVE IN LOS** Angeles area to operate own business with proven excellent support by major builder. Eugene E. Poole, 165 Lakewood Rd., Walnut Creek, CA 94598.

## POSITIONS AVAILABLE

**ORGAN TECHNICIAN: SCHOOL OF MUSIC, THE** University of Michigan seeks an experienced organ technician to tune and maintain Aeolian-Skinner concert organ, two studio organs and fifteen small practice organs. At least three years of successful experience tuning and maintaining large concert or church organs is required. A background which includes comparable responsibilities at another large School of Music and advanced degrees in music is preferred. Salary will be commensurate with experience and education. Send resume to: Barbara J. Burton, The University of Michigan, SCIL Personnel Service Center, 1020 Literature, Science and the Arts Building, 500 S. State St., Ann Arbor, MI 48109. A non-discriminatory, affirmative action employer.

## PIPE ORGANS WANTED

**SMALL 5-6 RANK PIPE ORGAN, PREFER TRACKER.** Small church. Contact: Bryant G. Parsons, 6707 Los Tios, Houston, TX 77083. (713) 879-0223.

**SMALL CHURCH NEAR NEW ORLEANS WANTS** used 3 to 5-rank unit organ. Please call. Mrs. J.R. Wilkins, (504) 464-9635.

**USED PIPE ORGAN WANTED. SEND SPECIFICA-** tion and price. Address MY-2, THE DIAPASON.

## MISCELLANEOUS WANTED

**TRADE OR BUY 1920'S MOLLER OR PILCHER** ivory drawknob heads. 1 1/2" x 3/4". Tom Martin, 621 Bailey Av., San Antonio, TX 78210.

**NEED AEOLIAN HARP. CONTACT: PIPE ORGAN** Sales and Service, Box 838, Lithonia, GA 30058. Weekdays, business hours, (404) 482-4845.

**MUSIC ROLLS FOR ANY PIPE ORGAN PLAYERS.** Other rolls too. W. Edgerton, Box 88, Darien, CT 06820.

**MUSIC ROLLS FOR AEOLIAN DUO-ART, WELTE** and Skinner Automatic Pipe Organ Players. J.V. Macartney, 406 Haverford Av., Narberth, PA 19072.

**NEED AUSTIN OR OTHER ORGAN BENCH. CHI-** cago. Advise price. Address SP-5, THE DIAPASON.

## MISCELLANEOUS

**WANT TO MAKE CONTACT WITH THOSE CON-** templating tonal additions, revisions, revoicing of E.M. Skinner or Aeolian-Skinner organs. Have valuable information to share. Address SP-1, THE DIAPASON.

**SEIKO ELECTRONIC TUNER: VERSATILE, COM-** pact, low-cost. Send SASE to Fine Lines, Box 245, Melrose, CT 06049.

**POSTERS; 40"x26" LASAR COLOR PRODUCED** Rodgers Pipe/Electronic at St. Francis Cultural Complex., Caceres, Spain. \$9 postpaid. 16"x20" color Carnegie Hall organ poster, \$5 postpaid. Both posters for \$12. Rodgers Posters, Box 548, Hillsboro, OR 97123.

## BUSINESS OPPORTUNITIES

**MUST SELL DUE TO ILLNESS, WHOLE OR IN-** part, organ business with shop and contents, consisting of: voicing chest with blower, bellows and keyboard, A-1 German leather, white bellows-valve glee-pneumatic heavy, medium, thin-gasket skins. Pipes: wood, metal, reed. Various organ parts and materials: console, magnets, valves, screws, rubber cloth, etc. Reasonable, below cost. Address SP-2, THE DIAPASON.

**PROFITABLE MIDWEST SERVICE/REPAIR/RE-** building business for sale. Business is over 50 years old. Please, serious inquiries only. Address MY-3, THE DIAPASON.

## PUBLICATIONS/ RECORDINGS

**HARPSICHORD MUSIC, SOLO AND ENSEMBLE.** Best editions from U.S. and European publishers. Also books on history, performance. Write for free catalogue. Zuckerman Harpsichords, Inc., Box 121-D, Stonington, CT 06378.

## PUBLICATIONS/ RECORDINGS

**THE FIRST RECORDING OF ORGANS BY 19TH** century organbuilder, John George Pfeiffer (1823-1910) of St. Louis, has been released. The two-record album "A Pfeiffer Odyssey," features four organs built between 1860 and 1879. Organists heard on the recording are Rosalind Mohsen and Earl Miller. Record Nr. OHS-200. \$16 (OHS members: \$13), includes shipping. Organ Historical Society, Box 26811, Richmond, VA 23261.

**"MAKE GLAD THE HEART" IS AN ANTHOLOGY** of Church and Funeral music. Heart-warming, melody-oriented, from Arcadelt and Bach to Zindel and Zingarelli. 52 selections and brief interludes with music for children's services and baptisms. 21 Prelude-Programs outlined. Quality printing. A beautiful book. \$18.75 plus \$1.35 postage and handling. (WA residents, state tax: \$1.46). Song River Publications, 10930 Meadow Rd. SW, Tacoma, WA 98499.

**SUBSCRIBE TO RECORD COLLECTORS BUY-** Seller Trade. Advertise free with \$8.50 subscription. Turn your unused records into cash. Record Collectors, 100 Lancaster St., Marietta, OH 45750.

**"THE ORGANS OF THE DIVINE WORD SEMI-** nary." Techny, Illinois. Leon Nelson, organist. Works by Campra, Lemmens, Walton, Lenel, others. Stereo LP. \$7.00, postpaid. Collector's item. Nelson, P.O. Box 380, Deerfield, IL 60015.

**THE ORGAN HISTORICAL SOCIETY IS OFFER-** ing a 16-page catalog of publications, recordings, and other items, many of which are produced by the OHS. The catalog also includes many hard-to-find popular books, recordings and tapes from other sources. Send 20¢ stamp to: OHS, Box 26811, Richmond, VA 23261.

**THE STOPT DIAPASON, A BI-MONTHLY PUBLI-** cation features illustrated articles regarding vintage organs in the midwest. Special articles deal with little-known, but extant instruments and their builders, as well as similar articles regarding organs that no longer exist. Published information is well-researched. Subscription only \$8 per year. Checks made payable to Chicago-Midwest OHS. Address orders with remittance to: Susan Friesen, Editor, The Stopt Diapason, 2139 Hassell Rd., Hoffman Estates, IL 60195.

**SCHOENSTEIN & Co.**  
EST. 1877  
**SAN FRANCISCO**

3101-20th Street · 94110 · (415) 647-5132  
Mechanical and Electric-Pneumatic Actions

**Parsons**  
**Organ Co.**  
EST. 1914

1932 PENFIELD ROAD  
PENFIELD, N.Y. 14526  
716-586-0383



## BERKSHIRE ORGAN COMPANY INC.

68 SO. BOULEVARD, WEST SPRINGFIELD, MASSACHUSETTS  
Area Code 413-734-3311, 736-1079

Member: American Institute of Organbuilders  
International Society of Organbuilders

## WANT A PRACTICE ORGAN? PEMBROKE PIPE ORGAN (in kit form)

Send stamp for brochure  
**THE ORGAN LOFT**

EPSOM, N.H. 03234 Tel. 603-736-4716

Remember: If it does NOT have pipes, it is NOT an organ

REPAIRING TUNING ADDITIONS

## R. W. KURTZ ORGAN CO.

CONSULTANT SPECIALISTS ON PIPE ORGAN REBUILDING

P. O. Box 32, Woodstown, N.J. 08098 · 609 / 769-2883

ORGAN BUILDERS



**L. W. BLACKINTON**  
and associates, inc.

380 FRONT ST.  
EL CAJON, CA. 92020

HELLMUTH WOLFF  
TRACKER ORGANS

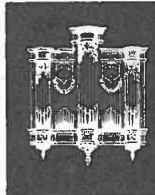

1260 rue Tellier  
Laval, Québec H7C 2H2

**Roy Redman**

Pipe Organ Builder  
2742 Ave. H

Fort Worth, Texas 76105

Tele. (817) 536-0090

**Scott R. Riedel**  
CONSULTANT IN ECCLESIASTICAL  
ACOUSTICS, MUSIC & ARCHITECTURE

11040 West Bluemound Road, Wauwatosa, Wisconsin 53226  
(414) 771-8966



## ORGAN SUPPLY INDUSTRIES

INCORPORATED

645 WEST 32ND STREET • P. O. BOX 1165 • ERIE, PA. 16512

QUALITY PIPE ORGAN SUPPLIES

## IT'S OUT!

OUR COMPLETE 68+ PAGE CATALOG  
ILLUSTRATED WITH CURRENT PRICE DATA!

SEND \$4.25 TODAY

**ARNDT ORGAN SUPPLY COMPANY**  
1018 LORENZ DRIVE - BOX 129  
ANKENY, IOWA 50021

**Mim Henry**

PIPE ORGANS  
Restorations, Design, Service

(216) 382-9396

1052 Roanoke Road  
Cleveland Heights, Ohio 44121

## MIDMER LOSH, INC.

ESTABLISHED 1860

## PIPE ORGAN BUILDERS

35 Bethpage Road  
Hicksville, New York 11801

(516) 681-1220

# ★ FRANK J. SAUTER and SONS Inc. ★

Phones: 388-3355

599-0391

Alsip, Illinois 60658

4232 West 124th Place

Organ Builders

- Repairing
- Contractual Servicing
- For Unexcelled Service
- Rebuilding



# CLASSIFIED ADVERTISING

Classified Advertising Rates  
will be found on page 30.

## PUBLICATIONS/ RECORDINGS

THE ORGAN LITERATURE FOUNDATION, world's largest supplier of organ books and recordings, offers a catalogue listing 1,100 plus items, at \$1.00 or 4 international reply coupons (refundable with first order). Write to: The Organ Literature Foundation, 45 Norfolk Rd., Braintree, MA 02184.

REPRINT OF HISTORIC ORGAN BROCHURE OF one-manual organs built by Marshall & Odenbrett of Ripon, Wisconsin, 19th Century. Send SASE and 25c in stamps or coin to: Susan Friesen, Editor, The Stopt Diapason, 2139 Hassell Rd., Hoffman Estates, IL 60195.

A COMPLETE LISTING OF ALL AVAILABLE back-numbers of THE DIAPASON is now available. Many from the 1930's on, and some older issues may also be obtained for your personal or library collection. Send SASE to: The Organ Historical Society, Box 26811, Richmond, VA 23261.

## HARPSICHORDS

SMALL, MEDIUM OR LARGE HARPSICHORDS, spinets and clavichords after various historic schools. Built to your requirements or choose from already completed instruments. Brochure available. Paul Y. Irvin, Instrument Maker, 221 Glenview Rd., Glenview, IL 60025. (312) 998-9829.

SPERRHAKE HARPSICHORD, 1666, 8 1/2' LONG, 16', 8', 8', 4', plus buffis, 5 pedals, FF-g, walnut veneer. \$2,000. Call Alex Sidorowicz, (607) 274-3348.

HANS NEUPERT TOP OF THE LINE BACH MODEL harpsichord. Well cared-for. \$9500, firm. Call (313) 882-8955 or (313) 881-1960.

DOWD FRENCH DOUBLE AFTER BLANCHET, 1976. 8' 8" 4", buff, transposing. In immaculate condition and perfect regulation. Exceptional tone. (MA) (413) 525-6722.

HARPSICHORDS BY ERIC HERZ. IMMEDIATELY available: Single manual, 18th century German tradition, 2x8' stops, oiled cherry or walnut, \$4950. Unfretted clavichord after Schiedmayer, walnut case, pearwood/ebony keyboard, \$3800. Free catalogue of instruments built to order. Eric Herz Harpsichords, 12 Howard St., Cambridge, MA 02139. (617) 868-6772.

## HARPSICHORDS

KNIGHT VERNON & CO. HARPSICHORD MAKERS. Authentic replicas of historic instruments carefully made and elegantly decorated. 525 White Pigeon St., Constantine, MI 49042.

HARPSICHORDS, PEDAL HARPSICHORDS, clavichords custom made. Jan H. Albarada, 14 Princess St., Elora, Ont. Canada N0B 1S0.

HARPSICHORDS, CLAVICHORDS, FORTEPIANOS. Custom instruments and kits. Write for free brochure. Zuckermann Harpsichords Inc., Box 121-D, Stonington, CT 06378.

BURTON HARPSICHORDS, SPINETTS AND CLAVICHORDS. Professional instruments in kit form from \$195. For brochure, write: Burton harpsichords, 727 "R" St., P.O. Box 80222D, Lincoln, NE 68508.

SPERRHAKE HARPSICHORDS AND CLAVICHORDS. Excellent, dependable, beautiful. Robert S. Taylor, 8710 Garfield St., Bethesda, MD 20034.

HARPSICHORD OWNERS; A FULL LINE OF AUDIO and visual chromatic tuners is now available to help you with your tuning requirements. For more information write: Peterson Electro-Musical Products, Dept. 20, Worth, IL 60482.

YVES A. FEDER HARPSICHORDS, CUSTOM INSTRUMENTS and reconditioning work. Authorized Agent Zuckermann kits sold at factory direct prices. Assistance to kit builders. North Chestnut Hill, Killingworth, CT 06417.

HARPSICHORDS, FORTEPIANOS, CUSTOM-BUILT from Hubbard and Zuckermann kits. Reasonable prices. Free brochure. R. Mark Rosa, Historical Keyboard Instruments, 625 W. Lakeside St., Madison, WI 53715.

## PIANOFORTE

BROWN AND ALLEN SQUARE GRAND PIANOFORTE. 150 years old. Excellent condition. Beautiful wood. Every note plays. \$4,500 or best offer. Leon Nelson, P.O. Box 380, Deerfield, IL 60015. (312) 367-5102.

## PIPE ORGANS FOR SALE

KIMBALL, 2-MANUAL, 4-RANK SELF-ENCLOSED electro-pneumatic pipe organ. Playing condition before disassembly. Excellent pipework. Optional Deagan M chimes and Moller/Deagan harp. \$3200 or offer. Electric Orchestras, Inc., 29962 N. Terre Dr., Libertyville, IL 60048. (312) 367-7996.

GLORIOUS 25-RANK MOLLER, 1912, INCLUDING 3-manual drawknob console (1942), three reed and three string stops. Great, Swell divisions straight. Now serves mid-sized church. Easily downsized. Sell all or part. Best offer removes January 1984. Mid-Ohio. (216) 283-8337.

11-RANK, 1949 FRITSCHKE. L/2 BASS PIPES, chest, excellent condition. Console fair. Complete organ. \$2000. Robert Figlio, Box 95, R.D. #4, Elmer, NJ 08318. (609) 358-8630.

WICKS PIPE ORGAN, 23 STOPS, 3 MANUALS, beautiful console on dolly, all excellent and playable; Church being renovated for other uses; new rectifier and Bobco blower; professional removal and packing available. Also available, pews and matching sanctuary furniture, light oak, colonial style, 600 capacity. Contact: Rev. Richard J. Sullivan, Gannon University, Erie, PA 16541. (814) 871-7434.

WURLITZER 2-MANUAL, 3-RANK LODGE PIPE organ #1006. Complete with bench and blower. Tubular pneumatic. Partially restored. Pipework excellent. Case needs restoration. \$3500 or offer. Electric Orchestras, Inc., 29962 N. Terre Dr., Libertyville, IL 60048. (312) 367-7996.

TELLERS 2-MANUAL, 3-RANK UNIFIED ORGAN, complete. Flute, Diapason, String. 5" wp. Spencer turbine blower. \$1,000. E & M Organ Co., Box 782, Whiteville, NC 28472.

WICKS, 1960, 2-MANUAL, 10-RANK PIPE ORGAN in excellent condition. \$15,000. Contact Dr. G. Julius Rice, Community Church, 2250 19th Av., Vero Beach, FL 32960. (305) 562-3633.

KIMBALL PORTABLE/RESIDENCE ORGAN. 6 stops, including 8' TC Trumpet. Opus Nr. 4020, ca. 1900. Measures 77" w x 75" d (including console) x 91" h. Pneumatic action with hand feeders. Free-reed pedal stop. Currently undergoing restoration by builder. Additional work can be performed to customer's specification at additional cost. Base price: \$32,500, includes delivery and set-up within 500 mile radius of Kenney, IL. For additional information contact: Schneider Pipe Organs, Inc., P.O. Box 37, Kenney, IL 61749. (217) 944-2454 or 668-2412.

## PIPE ORGANS FOR SALE

MIDMER/LOSH CHURCH ORGAN. ELECTRIC console, 12 ranks, 17 stops. Best offer. (215) 374-7365.

PIPE ORGAN: 2-MANUAL AND PEDAL, 7 STOPS, 9 ranks. Suspended mechanical action. To be completed in 1983. Address AU-1, THE DIAPASON.

MOLLER PIPE ORGAN, 17 RANKS, 1957, GOOD condition. Other pipe organ parts: consoles, wind-chests, pipes, harp. (817) 332-2953 or (817) 536-0090.

1963 BOSCH TRACKER, 2 MANUALS, 26 stops, 33 ranks, currently in use, moving to much larger facilities. Best bid over \$85,000. Inspect at your convenience. Available immediately. Contact: Dr. Kosche, Concordia College, 3201 W. Highland, Milwaukee, WI 53208. (414) 344-3400.

1958 MOLLER CONSOLE: 4-MANUALS, 88 drawknobs, 23 couplers, 46 pistons on six divisions. Good condition. Also 21-rank Moller pipe organ, 1924-26 vintage. Together or separately to highest bidder. Bids by December 1, 1983. Buyer to remove by June 1, 1984. Further information and bids to: St. John's United Church of Christ, 429 N. Washington, Owosso, MI 48867.

INTERESTED IN A SMALL TRACKER ORGAN? For free literature, contact Klug & Schumacher, Inc., 3604 Waterfield Pkwy., Lakeland, FL 33801. (813) 665-4802.

POSITIVE AND PORTATIVE ORGANS. WE MAKE instruments in the Baroque and Medieval traditions to your specification. For further information, please write: Paul F. Martin Organs, P.O. Box 6, Mansfield, Ontario, Canada, L0N 1M0.

NOEL MANDER OFFERS MEDIEVAL PORTATIVES, £825. Two fine early nineteenth century chamber organs, £6000 and £9000 and one by Green, about 1770, £10,000. All ex. works. Those interested, please send five dollar bill. Noel Mander, St. Peter's Organ Works, London E2, England.

MOLLER PIPE ORGAN, 1,000 PIPES. ST. ANGELO, TX. After 6 pm: (915) 944-7942. Days: (915) 944-4107.



Tracker Action Pipe Organs  
Rancho San Julian, Star Route  
Lompoc, CALIFORNIA 93436

## McMANIS ORGANS

Incorporated  
10th & Garfield  
KANSAS CITY, KANSAS  
66104  
A.P.O.B.A. Member

## VISSER-ROWLAND

713/688-7346  
2033 JOHANNA B  
HOUSTON 77055

Member  
International Society of Organbuilders  
Associated Pipe Organ Builders of  
America

## FOR SALE

This space as low as \$30 per issue on a 12-insertion contract.

Want more details? Rate card sent on request.

**THE DIAPASON**  
380 Northwest Highway  
Des Plaines, IL 60016

**Robert M. Turner**  
Organbuilder

13708-J Via del Palma  
Whittier, CA 90602 (213) 698-4550

**MAYLAND**  
Chime Co.  
... since 1866.

2025 Eastern Ave. Cincinnati, Ohio  
45202 221-5671 (513)

## TEWKSBURY ORGAN SERVICE

Pipe or Electronic Organs lifted into balconies. Organs removed, Facades for Pipe or Electronic organs designed and erected.

201-658-4142 (24 hours)  
Box 176, Pluckemin, New Jersey 07978

Restoration, Tuning,  
Maintenance

## PRAIRIE ORGAN COMPANY

2131-1/2 RIDGE AVENUE  
EVANSTON, ILLINOIS 60201  
(312) 864-4323

## KIEFER TANNING CO.

240 FRONT • GRAND RAPIDS, MI. 49504  
(616) 459-3401  
IMPORTED AND DOMESTIC LEATHER



**Builders of Fine Tracker and  
Electro-Pneumatic Pipe Organs**

*Inquiries are Cordially Invited*

## W. Zimmer & Sons

INCORPORATED  
Member APOBA

Mailing Address: P. O. Box 520, Pineville, N. C. 28134  
NATIONS FORD ROAD • CHARLOTTE, N. C.

SIMPLICITY—ACCESSIBILITY—RELIABILITY—TONAL SUPERIORITY—DURABILITY—QUALITY—

## AUSTIN ORGANS, INC.

ORGAN ARCHITECTS AND BUILDERS

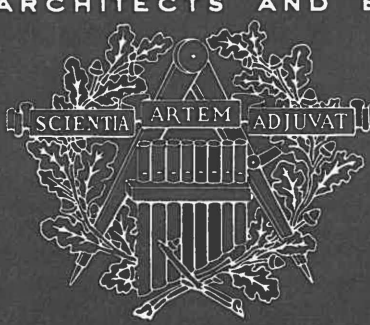

Since 1893

156 WOODLAND STREET - HARTFORD, CT. 06105 (203) 522-8293  
MEMBER: ASSOCIATED PIPE ORGAN BUILDERS OF AMERICA

—ACCESSIBILITY—DEPENDABILITY—QUALITY—TONAL SUPERIORITY—

# CLASSIFIED ADVERTISING

Classified Advertising Rates  
will be found below.

**ALL REPLIES  
TO BOX NUMBERS**  
that appear  
without an address  
should be sent to:  
**THE DIAPASON**  
380 Northwest Hwy.  
Des Plaines, IL 60016

## THEATRE ORGANS WANTED

WANTED, URGENT: THEATRE PIPE ORGAN, prefer 3-manual, approximately 10 rank Wurflitzer, but will consider all. Cash. Please write: Mr. Williams, P.O. Box 776, Clackamas, OR 97015.

## THEATRE ORGAN PARTS

8' SAXOPHONE, WOOD, HIGH-PRESSURE, reedless. Very authentic voicing. \$1,500. Crating and shipping at extra cost. Contact: Schreider Pipe Organs, Inc., Box 37, Kenney, IL 61749. (217) 944-2454 or 668-2412.

## REED ORGANS

REPLACEMENT REEDS AVAILABLE FOR USE IN parlour reed organs. Send inquiry to: Paul W. Toelken, Box 5017, Prescott Valley, AZ 86312.

## ELECTRONIC ORGANS FOR SALE

ALLEN, SYSTEM 705, LARGE, DELUXE, TWO-manual computer-type organ. Eight alterable voices, 32 foot pedal, eight speakers. A showroom model discounted to \$22,500, or make us an offer. Address SP-3, THE DIAPASON.

BALDWIN ELECTRONIC ORGAN, MODEL 11. Available by February 1, 1984. Sold as is. Minimum bid \$1500 or best offer by November 1, 1983. Contact: Rev. Kurt J. Kremlick, Jr., Southminster Presbyterian Church, Boise, ID 83709.

ALLEN, SYSTEM 123-3, WITH 150 CARDS. Condition; brand new. Reasonable. Dennis A. Dahlman, (612) 533-9570.

RODGERS ORGAN, TRIO 321, MINT CONDITION. 2 external speakers (one Leslie, one Rodgers), 3 keyboards, full pedalboard, bench and music books. \$5200. Chelmsford, MA. (617) 453-5236.

ARTISAN ORGAN, ELECTRIC, ABOUT 20 YEARS old. Beautiful Organ Supply console, 30 stops. Reisner mechanisms. In home in Chicago northern suburb. Must be seen and heard. Organist, Box 380, Deerfield, IL 60015. (312) 367-5102.

95 ALLEN, CONN, BALDWIN AND HAMMOND Church organs, 400 grands, \$1000 and up. Victor, 300 NW 54th St., Miami, FL 33127. (305) 751-7502.

## ELECTRONIC ORGANS SERVICES/SUPPLIES

SCHOBER COMBINATION ACTIONS: CRM-5 (Recital), and CTM-5 (Theatre), competently repaired. W.L. Exner, 3820 NE 85th St., Seattle, WA 98115. (206) 523-0063.

ELECTRONIC ORGAN PARTS, CONNECTORS for Leslie speakers, console shells, etc. No list, state requirements. Address, SP-6, THE DIAPASON.

## MISCELLANEOUS FOR SALE

11-RANK, 1949 MOLLER CHASSIS WITH TWO-manual drawknob console. Excellent condition. \$1500. Recent Moller Trumpet, \$800. Assorted parts. Robert Figlio, Box 95, R.D. #4, Elmer, NJ 08318. (609) 358-8630.

ORGAN PARTS FOR SALE: CONSOLES, chests, pipework, reservoirs, and other miscellaneous components, including parts for positif organ and 16' Principal facade pipes. Send SASE for list. Address SP-4, THE DIAPASON.

CUSTOM KEYBOARD ASSEMBLIES IN ANTIQUE styles; split sharps, nonstandard measurements. SASE to: Keyboards, 50 Columbia St., Newark, NJ 07102.

USED ELECTRIC CONSOLES, SWELL FRAME and motor, pipes (metal, wood and reed). Andover Organ Company, Inc., P.O. Box 36, Methuen, MA 01844.

2-HP BLOWER; 2-MANUAL, 3-MANUAL CONSOLES; Open and Stopped Diapasons; 16' Sub Bass; Dolce; Hohlfloete; Dulciana; Salicional; Voix Celeste; Gemshorn; Flute Harmonique; miscellaneous. Excellent condition, reasonable prices. Organ parts, harpsichords, pianos, considered as trades. Days: (703) 368-0335, nights: (301) 261-9272.

TWO MANUAL MOLLER ARTISTE CONSOLE, partially restored, manuals recovered, complete, \$350. Also have Dennison Vox Humana, \$50; Moller Gamba, \$200; Doppelfloete, \$30; and 16' Gedeckt, \$30. Pick-up only. Tom Spiggle, 4512 Woodside Rd., Old Hickory, TN 37138. (615) 847-2577.

1917 MOLLER RANKS: 8' DULCIANA, \$378; 8' Unda Maris, \$246; 8' Cornopean, \$447; 8' Aeoline, \$365; 4' Flute d'Amour, \$306; 16' Double Open Diapason, \$1095—with chest, \$1407. 8' Vox Humana, \$435—with chest, \$665. Contact: Bonnie Stephan, 54734 St. Rd. 13, Middlebury, IN 46540. (219) 825-9394.

RETIRING AFTER 67 YEARS OF TUNING, REPAIRING, rebuilding, etc. Send SASE for list of tools, materials and supplies. Bargain prices. Ray Douglas, So. Harpswell, ME 04079. (207) 725-7733.

NEAR-NEW 4' REGAL, 2 1/2" WP, \$250. 4' OBOE, \$85. 4-stop Hinners ventill chest, new magnets, \$225. 2 offsets, nearly new, 20 and 24-note, \$85 each. Austin Violin Diapason, 46 sc, \$200. Compact pedal keys, \$65. Hoyer Organ Co., 908 Lawrence Av., Lawrence, KS 66044. (913) 842-3332.

RETIRING: LOW PRICED FOR QUICK SALE. Moller Vox Humana, \$100; Moller Kinetic, all metal blower, 1/4-hp, \$150. Fifty Reisner chest magnets, \$50. String bass chest, 12 notes, \$40; Flute bass chest, 9 notes, \$40; Both for \$75. Two Rectifiers: 12 amps, \$50; 10 amps, \$25. Top and rack-board combinations, suitable for making unit chests, \$15 each. T.H. Shehan, 1306 E. 40th St., Savannah, GA 31404. (912) 233-7540.

## MISCELLANEOUS FOR SALE

2-MANUAL, ALL-ELECTRIC CASAVANT CONSOLE, oak case, 1971. Excellent condition. Tracker-touch 61-note ivory keyboards. Stop controls: Great, 10; Swell, 10; Pedal, 9. Usual registration aids. Asking \$6500. Available January 1984. Best offer for 8' Oboe; Pedal 16' Posaune (L/2), and 4' Schälmei, all 2" sp. St. John's Church, 906 S. Orleans, Tampa, FL 33606. (813) 259-1570.

HINNERS ORGAN, 9 RANKS, \$1,000 OR BEST offer. Miscellaneous ranks and chests; two and three-manual consoles. SASE for complete list. Norman Holmes, 308 Monroe, Charleston, IL 61920.

3-MANUAL MOLLER CONSOLE; APPROXIMATELY 25 ranks of pipes, blower. Ed Samson, (201) 782-3925.

HOOK 8' TRUMPET; SMALL-SCALE AUSTIN 16' Bourdon, with chest, 12 notes; miscellaneous 19th-century 16' Bourdon pipes; Flentrop AGO pedalboard. Pickup only. Evanston, IL (312) 869-5418.

KORG WT-12 CHROMATIC TUNER. 7-OCTAVE visual tuning range on lighted V-U meter: C#1 to C#8. 5-octave aural tuning: C#2 to C#7. Generates 2 volumes. Full calibration. Quartz crystal. Case, stand, AC adaptor, batteries, earphone. 1 lb. One year warranty. Introductory offer, \$135 ppd. (\$230 list). Song of the Sea Dulcimers, 47 West St., Bar Harbor, ME 04609. (207) 288-5653.

NEW LAUKHUFF 16' POSAUNE, 27 PIPES, 3" pressure; 8' Dulzian, 56 pipes, 2 1/2" wp; 4' Casavant Hohlfloete, 48 pipes (Phelps vintage); 2 Klann keyboards, combination action; swell motor; Kilgen swell motor; various zinc bass octaves. Bon Pipe Organs, 3310 SE 33rd Av., Portland, OR 97202.

RESUM-ART: PROFESSIONAL RESUMES FOR artists and musicians that reflect your qualifications with dignity. Send \$1 and SAE for details. Resum-Art, P.O. Box 578188, Chicago, IL 60657-8188.

ORGAN PARTS FOR SALE: CHESTS, CONSOLES, reservoirs, pipework, and many miscellaneous components. Send SASE with your inquiry stating your specific needs. Sorry, no list. Sold as-is, or rebuilt to your requirements. Address MY-4, THE DIAPASON.

2000 RARE DECO PIANOS AND ORGANS. 400 grands and church organs. Victor's, 300 NW 54th St., Miami, FL 33127. (305) 751-7502.

USED PIPES, CHESTS, CONSOLES AND MISCELLANEOUS equipment in good condition. Write: Box 2061, Knoxville, TN 37901.

2-MANUAL AUSTIN CONSOLE IN EXCELLENT condition, 6-stop straight chest, 5-stop chest with duplex action, pedal valve actions, 3/4-hp blower and some pipes. Good builder's project. C. Durham. (904) 575-2001.

## SERVICES/ SUPPLIES

K D KAPS ARE BACK! READY TO EASE YOUR up-coming tuning bouts with mixtures. Set of 7 kaps, \$12. K D Kaps, P.O. Box 223, Bolton, CT 06040.

WATKINS & WATSON CO. OF AMERICA. Complete line of "Discus" organ blowers and humidifiers, high and low speed, efficient operation, silencing cabinets. Immediate delivery on most items. Free catalogue, 11040 W. Bluemound Rd., Wauwatosa, WI 53226. (414) 771-8966.

## SERVICES/ SUPPLIES

THE NEW 7-OCTAVE PETERSON CHROMATIC Tuner, model 320, is now available from stock. Continuously variable Vernier control allows you to compensate for temperature or tune celeste ranks with ease. For more details: Peterson Electro-Musical Products, Dept. 31, Worth, IL 60482.

"SILENT KNIGHT" RIDES PESTS FROM ORGAN areas ultrasonically. Send SASE for details: Rive, Inc., 811 Focis St., Metairie, LA 70005.

NEW ORGAN PIPES TO YOUR SPECIFICATIONS. James Morris Organ Pipe Co., RD 3, Box 53-B, Smithfield, PA 15478.

RESERVOIR SPECIALIST, RELEATHERING AND Restoration. 20 years international experience. "That's right, Air Tight." Write: Keith P. Henderson, Air Tight Bellows Restorations, 4515 Merle Dr. B., Austin, TX 78745.

METAL ORGAN PIPES. FIRST CLASS WORKMANSHIP. Helmut Hempel Organ Pipes, 4144 W. 50th St., Cleveland, OH 44144.

"PIPE SHINE" CLEANS PIPES LIKE NEW. SASE for details: Rive, Inc., 811 Focis St., Metairie, LA 70005.

CUSTOM-MADE WOODEN REPLACEMENT parts for consoles, actions. Vintage-looking finishes. Ebony-capped pedal sharps made to your pattern. Robert M. Raiselis, Cabinetmaker, RFD White River Junction, VT 05001. (802) 295-5850.

ORGAN SERVICEMEN; WE WILL RECOVER Casavant and Skinner pouchboards, primary and offset actions. Write: Burness Associates, P.O. Box 344, Glenside, PA 19038.

TUNE EQUAL OR ANY HISTORICAL TEMPERAMENT with Widener Computer Tuner. Full details, write: Yves Albert Feder harpsichords, Box 640, Killingworth, CT 06417.

USED, REVOICED, CLASSIC PIPEWORK. Various registers offered for one-half price of new pipe-work. We will also revoice your romantic pipes on a time and materials basis. Contact: Schneider Orgelbau, Box 382, Niantic, IL 62551. (217) 668-2412.

NEW ORGAN PIPES, EXCELLENT WORKMANSHIP and expertly voiced. Formerly supervisor of Aeolian-Skinner pipeshop. Hans Rother, German Organ Pipecraft, 34 Standard St., Mattapan, MA 02126.

RECOVERING ANY TYPE OF POUCHES, PNEUMATICS and primaries in leather. Reservoirs re-leathered also. Write: Eric Brugger Releathering Service, 1034 East 29th St., Erie, PA 16504.

RELEATHERING ANY TYPE POUCH, PNEUMATIC, bellows or action. Long years of experience and accurate workmanship. Jacob Gerger & Son, P.O. Box 245, Croydon, PA 19020. (215) 788-3423.

NEW WOOD ORGAN PIPES, VOICED OR UNVOICED. Fine workmanship. Artisan Builders, 806 N.P. Av., Fargo, ND 58102. (701) 293-8964.

HARPSICHORD/ORGAN TUNER. SET ANY TEMPERAMENT automatically with AccuTone tuner. Prices discounted. Carl Dudash Harpsichords, 11 Jewel St., Enfield, CT 06082.

## CLASSIFIED ADVERTISING RATES

Regular classified advertising is single paragraph "want ad" style. First line only of each ad in bold face capital type.

Display classified advertisements are set entirely in bold face type with the first line in capital letters and the addition of a ruled box (border) surrounding the advertisement.

Regular Classified, per word . . . . . \$ .30  
Regular Classified minimum . . . . . 5.00  
Display Classified, per word . . . . . .40  
Display Classified minimum . . . . . 15.00

Additional to above charges:  
Box Service (mail forwarding) . . . . . 2.50  
Billing charge to non-established accounts (per insertion) . . . . . 2.00

Closing Date (Classified): the first (1st) of the month for the next month's issue (Jan. 1st for the Feb. issue).

Non-subscribers wanting single copies of the issue in which their advertisement appears should include \$2.00 per issue desired with their payment.

The Diapason reserves the right to designate appropriate classification to advertisements, and to reject the insertion of advertising deemed inappropriate to this magazine.

# THE DIAPASON • 380 NORTHWEST HIGHWAY • DES PLAINES, IL 60016

Insert the advertisement shown below or enclosed in the Classified Advertising section of THE DIAPASON for the following issue(s): \_\_\_\_\_

Category \_\_\_\_\_  Regular  Boldface

Ad Copy \_\_\_\_\_

\_\_\_\_\_

\_\_\_\_\_

\_\_\_\_\_

\_\_\_\_\_

\_\_\_\_\_

\_\_\_\_\_

\_\_\_\_\_

\_\_\_\_\_

\_\_\_\_\_

\_\_\_\_\_

Name \_\_\_\_\_ Phone \_\_\_\_\_

Address \_\_\_\_\_ Total Enclosed \_\_\_\_\_

City/State \_\_\_\_\_ Zip \_\_\_\_\_ Date Sent \_\_\_\_\_



# Harris Organs

Pipe  
Organ  
Builders

7047 South Comstock Avenue, Whittier, California 90602 • (213) 693-4534

David C. Harris, Owner and Tonal Director • Member: International Society of Organ Builders, American Institute of Organ Builders • Inquiries are cordially invited.

**SCHNEIDER**  
**ORGELBAU WERKSTATT, Inc.**  
New Instruments — Rebuilds  
Tonal Alterations — Revoicing  
Revoiced Classic Pipework —  
Organ Maintenance  
Workshops in Niantic & Kenney, Illinois  
P.O. Box 382 Niantic, IL 62551  
(217) 668-2412 944-2454

**Robert Copeland**  
R.D. 3, Box 81  
Saltsburg, PA 15681  
(412) 639-9798  
*Pipe Organ Repair - All Makes*

CREATIVE ORGAN BUILDING FOR ARTISTIC MUSICAL RESULTS  
**Greenwood Organ Company**  
P. O. BOX 18254, CHARLOTTE, N.C. 28218  
"THREE GENERATIONS OF ORGAN BUILDING"

**ANDOVER**  
Box 36 Methuen, Massachusetts 01844  
Mechanical Action Specialists

**BRUNZEMA ORGANS INC.**  
596 Glengarry Crescent South  
Post Office Box 219  
Fergus, Ontario Canada  
N1M 2W8 (519) 843-5450

**martin ott pipe organ company inc.**  
11624 Bowling Green Drive  
St. Louis, Missouri 63141  
(314) 569-0366

**Schantz**  
**ROBERT C. NEWTON**  
Northern California Representative  
Sales and Service  
518 Lorraine Avenue San Jose, CA 95110 Telephone (408) 998-0455

**JULIAN E. BULLEY**  
New Organs — Rebuilding  
Service  
SINCE 1906  
1376 Harvard Blvd.—Dayton, Ohio 45406  
513-276-2481

Your personal wishes  
are in good hands  
**Jacques Stinkens**  
Organ pipe makers B.V.  
**ZEIST**  
Holland

(305) 523-7247  
**WALTER A. GUZOWSKI**  
PIPE ORGAN SERVICE  
Business 1121 E. Commercial Blvd. Ft. Lauderdale, Fla. 33334 Home 1225 S.W. 4th Ct., Apt. B Ft. Lauderdale, Fla. 33312

**Klug & Schumacher, Inc.**  
PIPE ORGAN BUILDERS  
Member AIO and ISO  
3604 Waterfield Parkway  
Lakeland, Florida 33801  
Phone (813) 665-4802

**Lewis & Hitchcock, Inc.**  
Pipe Organ Builders Since 1915  
8466A Tyco Road Vienna, Virginia 22180  
(703) 734-8585

**ROCHE**  
Organ Co., Inc.  
799 West Water Street  
Taunton, Mass 02780.  
pipe organs

**RANDALL S. DYER**  
Pipe Organs and Organ Service  
Box 489  
Jefferson City, Tennessee 37760



ORGAN COMPANY, INC.

WASHINGTON ROAD  
PRINCETON, NEW JERSEY 08540

## ELECTRO-MECHANICAL ACTION

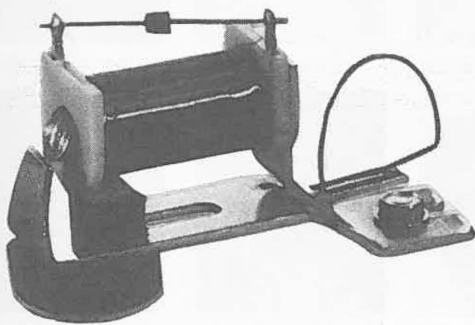

- COLOR CODED WINDINGS
- 60, 90, 140 OHM COILS
- INSTALLS WITH ONE SCREW
- SLOTTED DESIGN FOR FAST INSTALLATION
- 8 X 3/4" HARDENED SCREW INCLUDED
- SPARK-SUPPRESSING DIODE INCLUDED
- 5/16" DIAMETER CORE
- FULCRUM PIVOT HINGE DESIGN
- ALL STEEL PARTS ARE FULLY PLATED
- CAN OPERATE ON HIGH WIND PRESSURE
- 1/2, 5/8, 3/4, 7/8, 1, 1-1/8" VALVE SIZES

**PRICE: \$2.00 EACH**

SHIPMENT INCLUDED IN 48 STATES  
5 OZ. TUBE OF VALVE ADHESIVE \$5

**JUSTIN MATTERS**

15 E. ELIZABETH ST., ST. PAUL, MN 55107

**MANUFACTURING METAL ORGAN PIPES**  
**THE WORLD'S FINEST DISPLAY PIPES — POLISHED ALUMINUM**

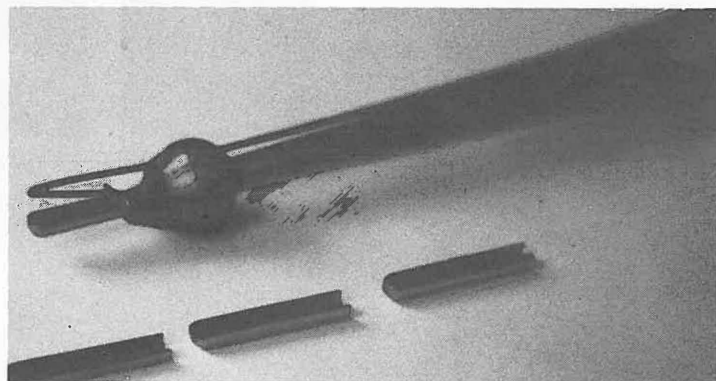

Reed pipes of any type made to custom scaling in excellent quality.

Parts such as resonators, blocks, boots, shallots, tuning wires, wedges, and reeds can also be supplied.

Inquiries are cordially invited.

Sale only to organ builders.



**AUG. LAUKHUFF**

The world's largest Suppliers  
for all pipe organ parts

D 6992 Weikersheim,  
West Germany

# Murtagh-McFarlane Artists, Inc.

3269 West 30th Street  
Cleveland, Ohio 44109  
(216) 398-3990



William Albright

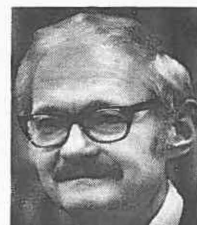

David Craighead



Gerre Hancock



Judith Hancock



Clyde Holloway



Marilyn Keiser



Joan Lippincott



Marilyn Mason



James Moeser



George Ritchie



Donald Sutherland

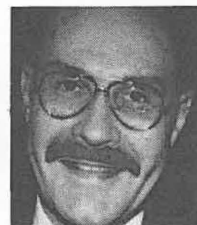

Frederick Swann



Ladd Thomas

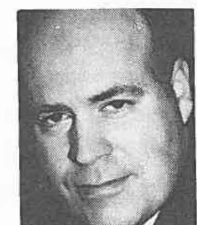

John Weaver



Todd Wilson

## Future Availability

Peter Planyavsky  
Simon Preston  
Daniel Roth

## Available Mar., 1984

Guy Bovet

## Available Sept. 23— Oct. 14, 1984

Susan Landale/Petr Eben

## Available Oct.—Dec., 1984

Martin Neary

## All-Bach Concerts, 1985

Marie-Claire Alain, October  
William Albright  
Peter Hurford, April/May  
Joan Lippincott

James Moeser  
George Ritchie  
Lionel Rogg, March  
Heinz Wunderlich, limited